

## Belmont sash pulley instructions

### Contents

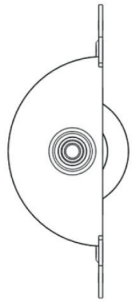

Pulley Body



Face Plate



X2 Face  
Plate Screws

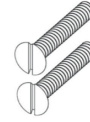

X2 4mm  
Wood Screws

Use the face plate to mark the pulley position on the window frame with a pencil.

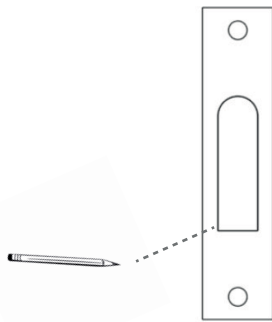

Find the centre point and mark out a H67mm x W22mm rectangle. Use these markings to make a 40mm deep cavity to house the pulley body.

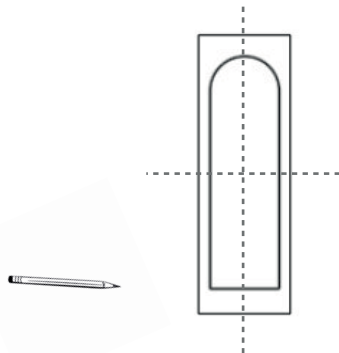

## Belmont sash pulley instructions

Push the pulley body into the cavity and mark all 4 holes with a pencil. Drill pilot holes in the frame for the centre points closest to the cavity.

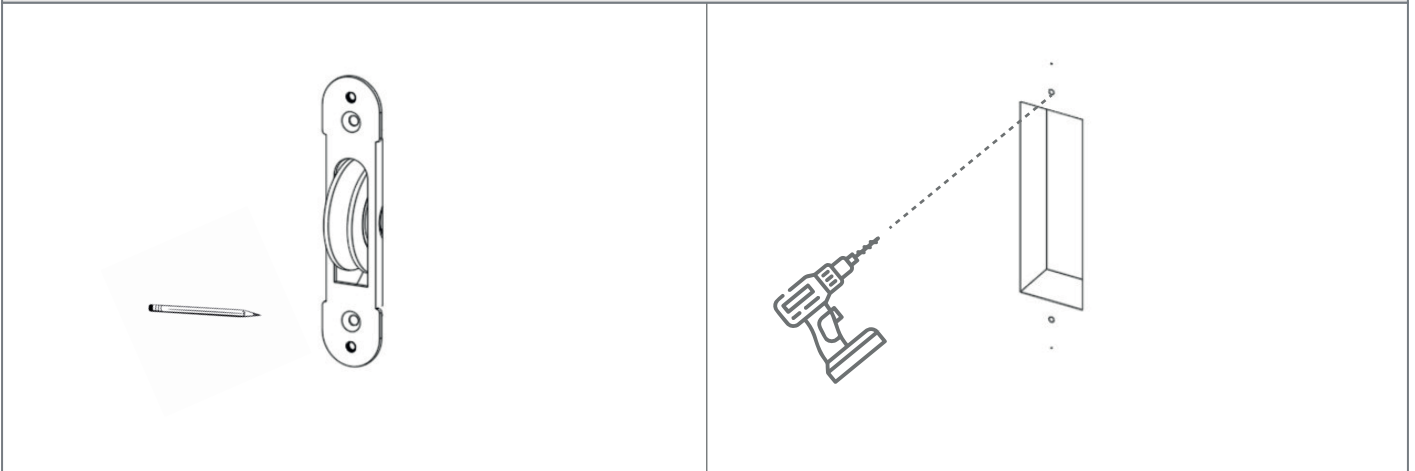

Line the face plate up with the outward most holes and draw a line around the edge. Use this rectangle as a template to recess the plate 4mm into the frame.

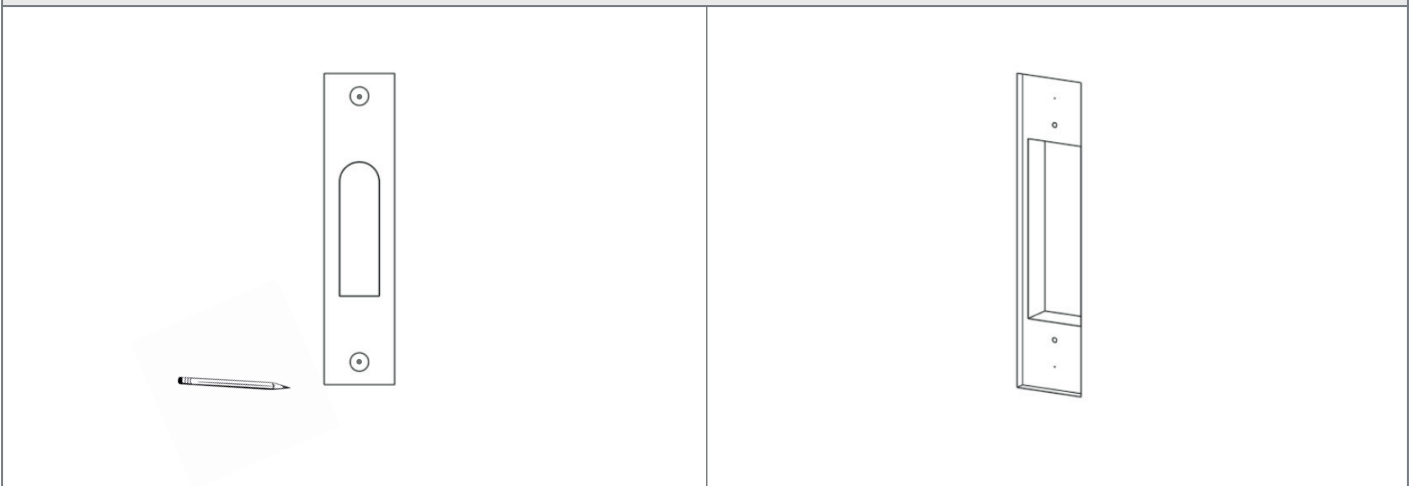

Use the supplied wood screws to install the pulley body before using the front plate screws to install the face plate.

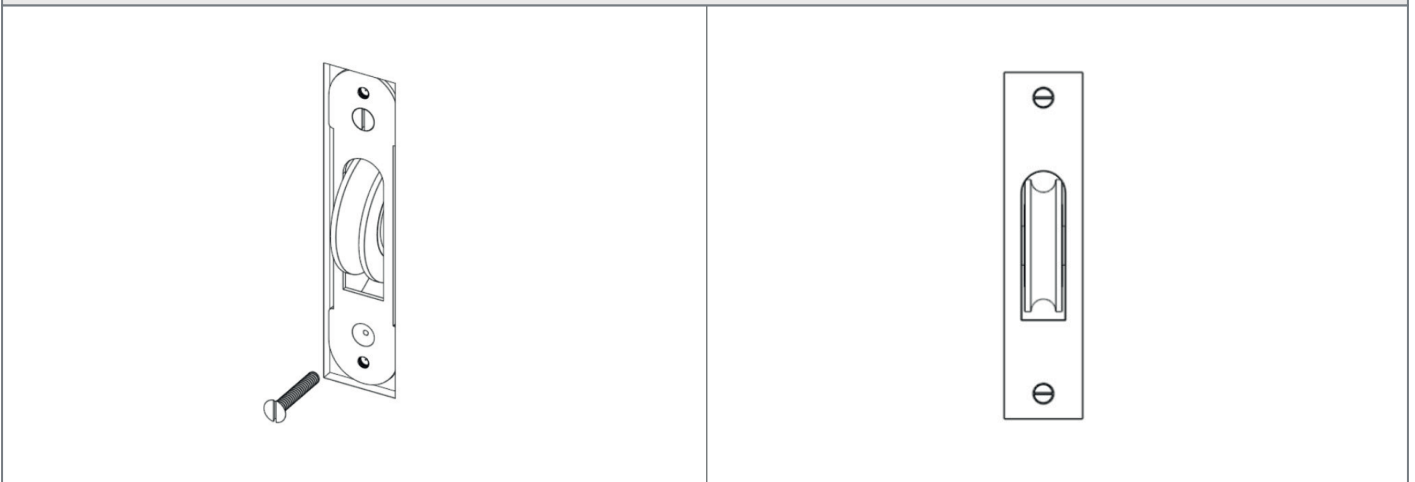

**Belmont sash stop instructions**

**Contents**

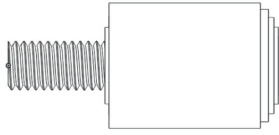

X2 Belmont sash stop

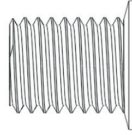

X2 Threaded wood insert

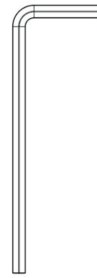

Hex key

Mark the position of the stop on the window before drilling a 13mm deep cavity with a 10mm drill bit for the threaded insert.



Install the threaded insert using a 6mm hex key.



Use the hex key provided install the stop to the window.

