



Molift Quattro

The temporary hoist solution with excellent stability

A freestanding traverse gantry

Molift Quattro is a freestanding hoist unit that offers a (four post) Traverse System which is the best solution for temporary hoisting needs or when the facility is not built for fixed installations. The gantry is easy to install without the need to mount additional fixtures on walls or ceilings. It is ideally suited for temporary hoist applications in nursing or private homes.



Solves most overhead lifting situations

The traverse has a lightweight aluminum frame and four steel posts that provides excellent stability and covers the surface of the hoisting requirement. Molift Quattro solves all overhead lifting situations together with the Molift Air or Molift Nomad hoist motor and a sling. With a lifting capacity of max 300 kg, it is ideal for lifting and transferring a person from or to bed, floor, chair, wheelchair, toilet etc.

Molift Quattro can be delivered in two sizes: 3x3 meters and 4x4 meters. The length of the posts are fixed. The lowest allowed distance from floor to ceiling is 2.40 meters.

Molift Air or Molift Nomad with trolleys are ordered separately.

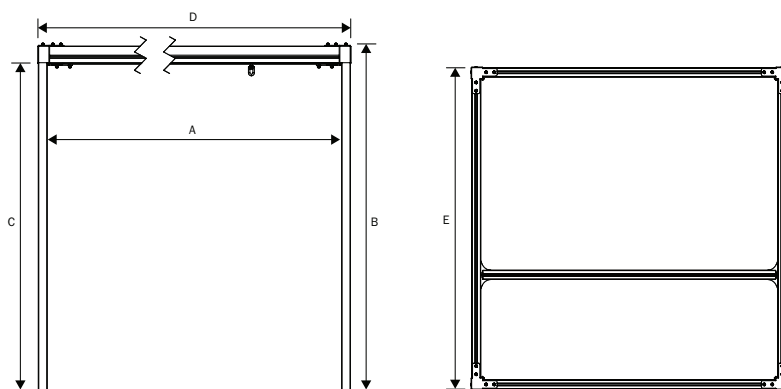

A: Travers lengths	3 or 4 m
B: Height	
Without feet	2.33 m
With adjustable feet (accessory)	2.38 - 2.43 m
C: Internal height without feet	2.19 m
D: Width	3.16 - 4.16 m
E: Depth	3.16 - 4.16 m
A x C: Max internal space	
Without feet	3 x 2.19 m
	4 x 2.19 m
With adjustable feet	3 x 2.24 m - 2.29 m
	4 x 2.24 m - 2.29 m

Product name	Internal space	Item no.	Facts
Molift Quattro 3	3x3 m	1600030	Safe Working Load: 300 kg Material: Steel, Anodized Aluminum, Plastic Expected Lifetime: 10 years
Molift Quattro 4	4x4 m	1600035	
Facts			Cleaning Clean/disinfect the product using a standard non-abrasive cleaning agent with a pH between 5 and 9, or with a 70% disinfectant solution.
Weight of unit: • Skinner Kg/m: 4.2 kg/m/8.8 lbs/m • Leg with adjustable feet: 8.5 kg/18.7 lbs • Corner: 2.7kg/6 lbs • Total weight (Complete unit) (3x3 m): 110.95 kg • Total weight (Complete unit) (4x4 m): 131.55 kg			



Features



Supreme stability and manoeuvrability

Molift Quattro is a gantry system which has supreme stability and provides access in all lifting situations.



Charging of hoist motor

Molift hoist motors can easily be charged through the hand control or through the in-rail charging option.



Easy to install

Molift Quattro is designed for quick installation by one or (preferably) two persons.



Accessory

Adjustable Foot

The Molift Quattro can be optimized with a height adjustable foot on each leg..
Item no 1610200



For the latest news and continuously updated product information – visit www.etac.com