

SPECIFICATION SHEET



JOB NAME: _____

LOCATION: _____

QUOTE/REF#: _____

SPECIFICATIONS

Brightness:	1000 Lumens
Power:	15 watt
Input Voltage:	120V AC
LED CCT:	3000K
CRI:	90+
IP Rating:	IP20
Environment:	Indoor Use - Dry Location
Beam Angle:	Adjustable 15° - 50°
Length:	3.75 in / 95 mm
Diameter:	2.125 in / 54 mm
Max Ext.:	6.25 in / 159 mm
Finish:	Black or White
Manufacturer:	Elumalight
Rating:	ETL Listed
Avg. Lifetime:	± 30,000 - 50,000 hours
Warranty:	2 years limited

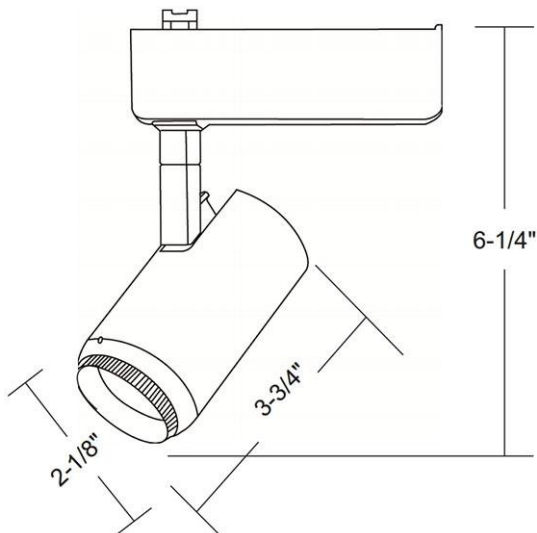

DESCRIPTION

The LED Adjustable Beam Track Heads are made from premium materials and available in White or Black finishes with a 15° - 50° adjustable beam angle. This LED Track Head offers great function and value for your lighting project. It is part of Step 1 Dezigns Track Lighting Collection, so make sure to check out other LED track lighting fixtures to accessorize your space.

KEY FEATURES

- Great for Store Display Fixtures
- 90-degree vertical movement of 345-degree horizontal rotation
- Use with 120V Single or Double Circuit Track or 120V Monopoints System
- Die-Cast Aluminum Construction
- CREE LED COB
- UL Listed

APPLICATIONS

- Tradeshow Booth
- Exhibit and Displays
- Retail Store Lighting
- Commercial Application



SPECIFICATION SHEET

Order SKUs

Product SKUs	Finish	Color Temperature
EL-TKH756-30K-BK	Black	3000K Warm White
EL-TKH756-30K-WH	White	3000K Warm White

