

SPECIFICATION SHEET

JOB NAME:

LOCATION:

QUOTE/REF#:



SPECIFICATIONS

Brightness:	400 Lumens
Power:	5 watt
Voltage:	12V DC
LED CCT:	3000K or 5000K
CRI:	90+
IP Rating:	IP20
Environment:	Indoor Use - Dry Location
Beam Angle:	40°
Head Length:	2 in / 51 mm
Head Diameter:	2.125 in / 54 mm
Head Max Ext.:	4.375 in / 111 mm
Finish:	Black, White, or Brushed Nickel
Manufacturer:	Elumalight
Rating:	UL Listed
Avg. Lifetime:	± 30,000 - 50,000 hours
Warranty:	2 years limited

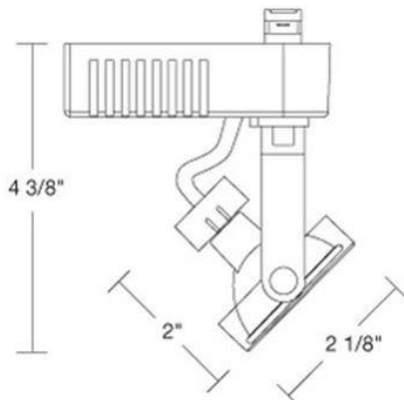

DESCRIPTION

LED MR-16 Low Voltage Gimbal Ring Track Head for use with the H-Style Track System. Call 800.822.8527 or e-mail sales@step1dezigns.com for J or L style version

KEY FEATURES

- Adjustable track adaptor to allow for use with single or double circuit track
- Great for Retail Store Display Fixtures
- 90-degree vertical movement of 358-degree horizontal rotation
- Metal housing gimbal built to last
- LED 5 Watt MR-16 Bulb Included with 3000K or 5000K LED CCT options
- Low Voltage Electronic Transformer Included
- UL Listed

APPLICATIONS

- Tradeshow Booth
- Exhibit and Displays
- Retail Store Lighting
- Commercial Application



SPECIFICATION SHEET

Order SKUs

Product SKUs	Finish	Color Temperature
EL-TKH10-30K-BK	Black	3000K Warm White
EL-TKH10-30K-WH	White	3000K Warm White
EL-TKH10-30K-BN	Brushed Nickel	3000K Warm White
EL-TKH10-50K-BK	Black	5000K Cool White
EL-TKH10-50K-WH	White	5000K Cool White
EL-TKH10-50K-BN	Brushed Nickel	5000K Cool White