

EL-BATT-12-3.2 12V 3.2 Ah SLA Trade Show Battery Kit

SPECIFICATION SHEET

JOB NAME:

LOCATION:

QUOTE/REF#:



SPECIFICATIONS

Battery Type:	Polymer Lithium-ion
Input:	12V (3.2 Ah)
Output:	12V (3.2 Ah)
Charging Time:	Up to 6 Hours
Life Cycles:	Up to 500 times
Dimensions:	5.28 in. L x 2.64 in. W x 2.36 in. H 134 mm L x 67 mm W x 60 mm H
Power Method:	Plug N Play or Hardwire
Environment:	Dry Location
IP Rating:	IP20
Manufacturer:	Elumalight
Warranty:	1 Year Limited

DISCHARGE CURVE 25°C (77°F)

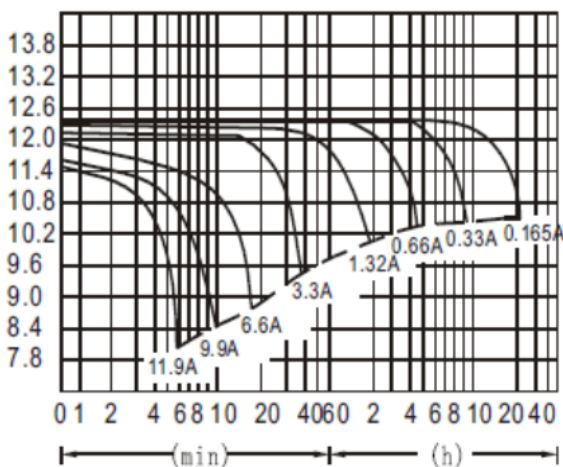

DESCRIPTION

Our 12V 3.2 Ah SLA Trade Show Battery powers selection of LED Trade Show Exhibit Lights up to 8 hours on a full charge. Once depleted, this versatile device fully recharges in up to 6 hours with our 2A EL-BATCHRG-12-2A Charger.

Our Trade Show Battery is much more than just a simple battery pack capable of powering our LED exhibit and display lights. So go off the grid and stop paying those outrageous electric fees at the trade show venues. The 12V 3.2 Ah SLA Trade Show Battery Kit pays for itself after only one or two events.

Need help with your LED lighting applications? Our lighting experts are here to help! Contact us today for assistance with lighting plan or installation instructions.

KEY FEATURES

- Mobile and Versatile design to fit in island display
- Completely eliminate or lower your electric rental costs.
- No more waiting for electrical power installation
- Power 1 LED 5w Telescoping Display Arm lights for up to 8 hours on a full charge.
- Easy to setup, No need for under-carpet outlets.
- Full charge in just over 4-6 hours
- Easy to use with our LED arm lights, LED Puck lights, LED Ribbon Tape Lights, etc.
- In-house technical expertise can adapt our Trade show Battery Kit to almost any LED Lighting.

APPLICATIONS

- Power Bank for Tradeshow, Exhibition, Retail Display Arm Lights
- Custom DIY projects

DIMENSIONS

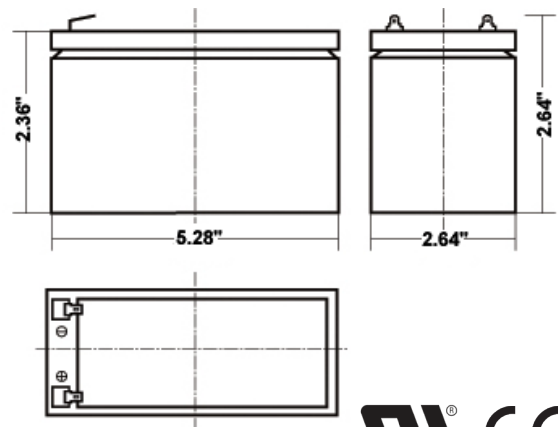

BATTERY RUN-TIME CALCULATION

First, Calculate Total Power Consumption Wattage of the 12V DC LED Fixture:

- **Total Power Consumption (watts) = Power Consumption (watts/ft) x Length (ft)**
- For example, if the LED 12V DC Tape light runs 3 watts per ft and the project requires 16 ft of LED Tape Light, then the total power consumption is **3 watts x 16 ft = 48w**

Secondly, Calculate the Amp Power:

- **Amp Power = Total Power Consumption (watts, calculated in step 1) / 12V DC**
- For example, the amp power of the 3 watts per ft 12V DC LED Tape Light is **48 watts ÷ 12V DC = 4 Amps**

Finally, Calculate the Runtime:

- **Total Runtime = Amp Hour (Ah) of the Battery ÷ Amps (calculated in step 2)**
- The total runtime of STDC12-3.2 battery with 3 watts per ft 12V DC LED Tape Light is **3.2 Amp Hour ÷ 4 Amps = 0.2 Hour**

ACCESSORIES



**Power Charger & Power Cord
Included**



**EL-TCA-29 2.1mm Male DC Cord
EL-TCA-30 2.5mm Male DC Cord
Sold Separately**

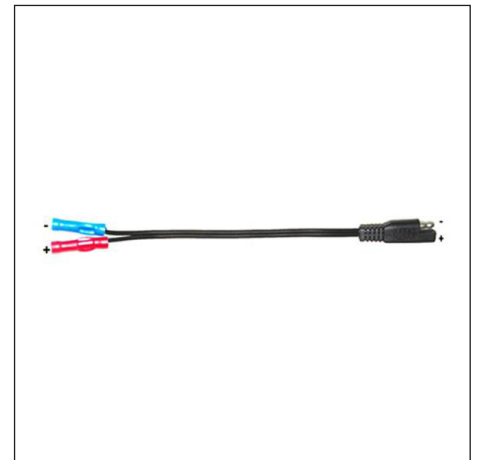

**Hardwiring Power Cord
Sold Separately**