

### SPECIFICATION SHEET

JOB NAME:

LOCATION:

QUOTE/REF#:



### DESCRIPTION

The 3 in. LED Square Trim inserts are engineered with energy-efficient LED technology that produces even illumination with an incredible 93+ CRI. Designed to be used for New Construction, Remodel, and Retrofit applications, these inserts are rated for a life up to 50,000 hours, and meet the Title 24 and Energy Star requirements. Suitable for IC and Non-IC housings.

The best choice for simple exhibit and display lighting projects. It produces even illumination without diode image. The low profile unit is CA Title 24 compliant, meets ENERGY STAR requirements, and UL wet listed. It produces 700 lumens.

### SPECIFICATIONS

<b>Brightness:</b>	700 Lumens
<b>Power (Watts):</b>	9 Watt
<b>Voltage:</b>	120V AC
<b>LED CCT:</b>	3000K
<b>Beam Angle:</b>	90°
<b>CRI:</b>	93+
<b>Dimmable:</b>	Yes, Triac/ELV
<b>Environment:</b>	Wet or Dry Location
<b>Aperture:</b>	3 in
<b>Dimensions:</b>	4.375 in L x 4.375 in W x 2.75 in H
<b>Finish:</b>	White - EL-332-30K-WH Bronze - EL-332-30K-BZ
<b>Trim:</b>	Reflector
<b>Manufacturer:</b>	Elumalight
<b>Rating:</b>	Energy Star, cULus Wet Listed, CEC Title 24, Meets ASTM-E283 Airtight Requirements
<b>Avg. Lifetime:</b>	± 30,000 - 50,000 hours
<b>Warranty:</b>	5 Year Limited

### KEY FEATURES

- Easy to Install
- Even Lighting Illumination
- Low-heat dissipation
- Long lifespan 50000 hours
- Energy Star Listed
- cULus Wet Listed
- CEC Title 24 Listed
- Meets ASTM-E283 Air Tight requirements

### APPLICATIONS

- LED Bathroom Lighting
- Residential Ceiling Down Lighting
- Commercial Ceiling Down Lighting
- Living Room Lighting
- Office Lighting
- LED Kitchen Lighting
- Pot Lights

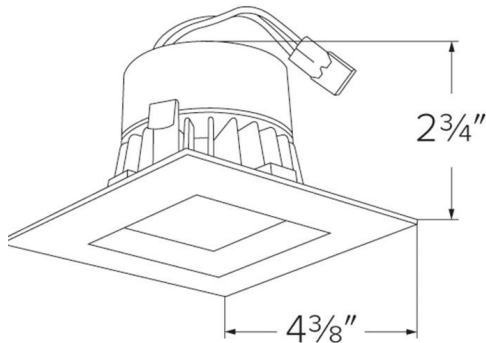

### SPECIFICATION SHEET

JOB NAME:

LOCATION:

QUOTE/REF#:



### DESCRIPTION

The 3 in. LED Square Trim inserts are engineered with energy-efficient LED technology that produces even illumination with an incredible 93+ CRI. Designed to be used for New Construction, Remodel, and Retrofit applications, these inserts are rated for a life up to 50,000 hours, and meet the Title 24 and Energy Star requirements. Suitable for IC and Non-IC housings.

The best choice for simple exhibit and display lighting projects. It produces even illumination without diode image. The low profile unit is CA Title 24 compliant, meets ENERGY STAR requirements, and UL wet listed. It produces 700 lumens.

### SPECIFICATIONS

<b>Brightness:</b>	700 Lumens
<b>Power (Watts):</b>	9 Watt
<b>Voltage:</b>	120V AC
<b>LED CCT:</b>	3000K
<b>Beam Angle:</b>	90°
<b>CRI:</b>	93+
<b>Dimmable:</b>	Yes, Triac/ELV
<b>Environment:</b>	Wet or Dry Location
<b>Aperture:</b>	3 in
<b>Dimensions:</b>	4.375 in L x 4.375 in W x 2.75 in H
<b>Finish:</b>	White - EL-331-30K-WH Bronze - EL-331-30K-BZ
<b>Trim:</b>	Baffle
<b>Manufacturer:</b>	Elumalight
<b>Rating:</b>	Energy Star, cULus Wet Listed, CEC Title 24, Meets ASTM-E283 Airtight Requirements
<b>Avg. Lifetime:</b>	± 30,000 - 50,000 hours
<b>Warranty:</b>	5 Year Limited

### KEY FEATURES

- Easy to Install
- Even Lighting Illumination
- Low-heat dissipation
- Long lifespan 50000 hours
- Energy Star Listed
- cULus Wet Listed
- CEC Title 24 Listed
- Meets ASTM-E283 Air Tight requirements

### APPLICATIONS

- LED Bathroom Lighting
- Residential Ceiling Down Lighting
- Commercial Ceiling Down Lighting
- Living Room Lighting
- Office Lighting
- LED Kitchen Lighting
- Pot Lights

