

RECOMMENDED TOOLS

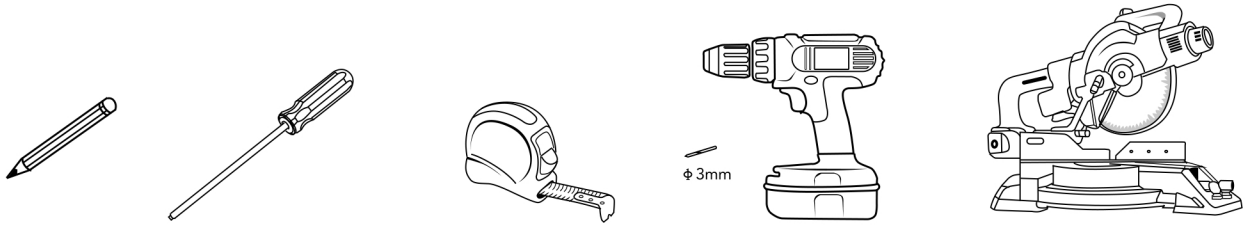

 Use power tools with caution and wear protective equipment.

 Use of drop saw with blade for aluminum cutting is essential.

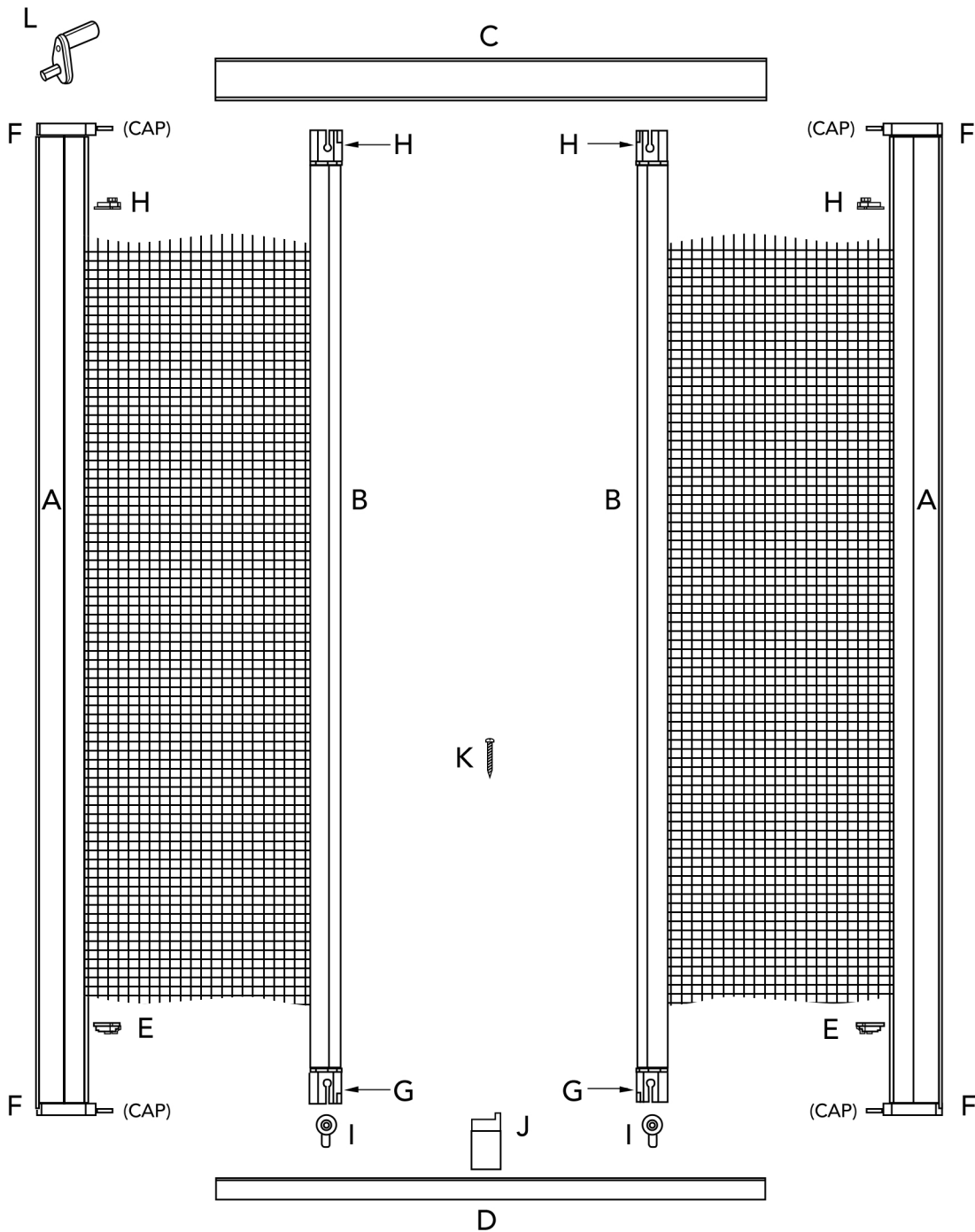

1 DOOR MEASUREMENTS

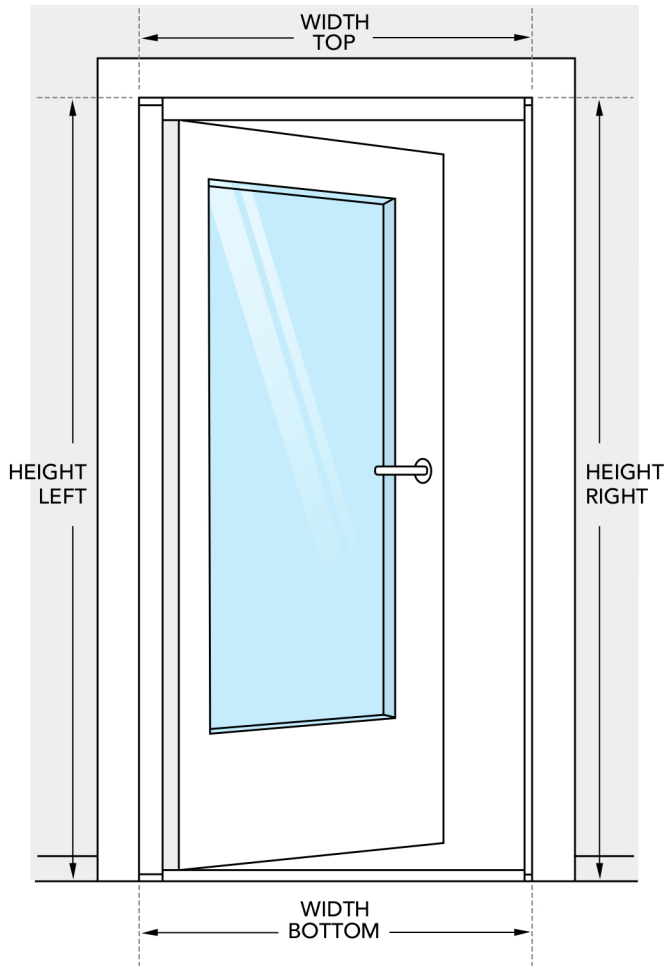

2 DISASSEMBLING CASSETTE

Disassemble only on the side with attached measuring tape.

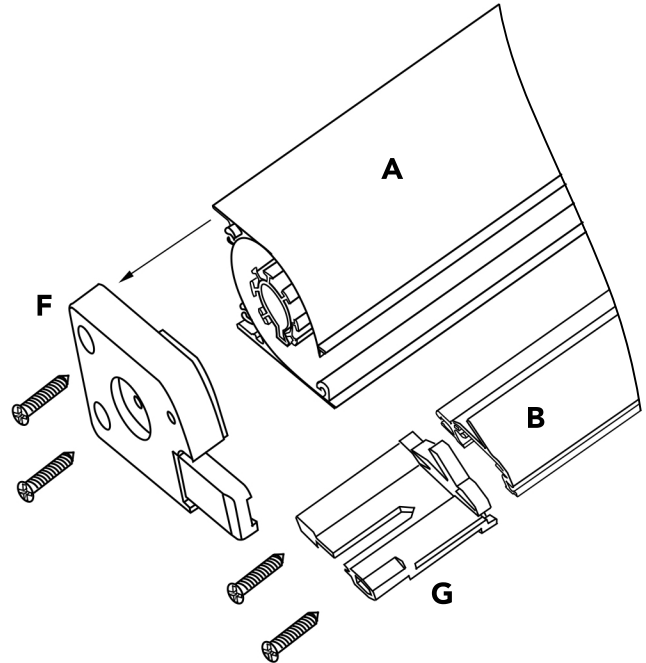

3 CUTTING EXAMPLE

Example: If the desired overall height is 2000mm, cut piece A to 1992mm to account for the end cap. Slide handle rail flush with the open end of cassette, then make your cut taking equal amounts off both parts

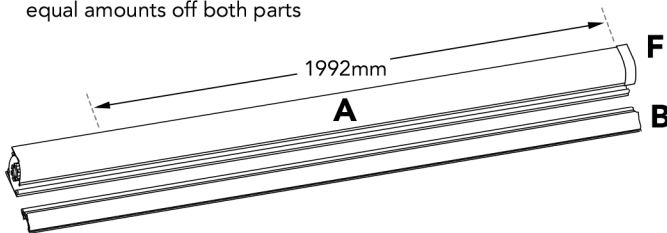

Example: If the desired overall width is 1600mm, cut pieces C & D to 1500mm to account for the 100mmW cassette

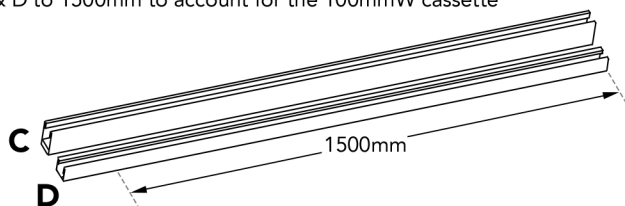

4 ASSEMBLING CASSETTE

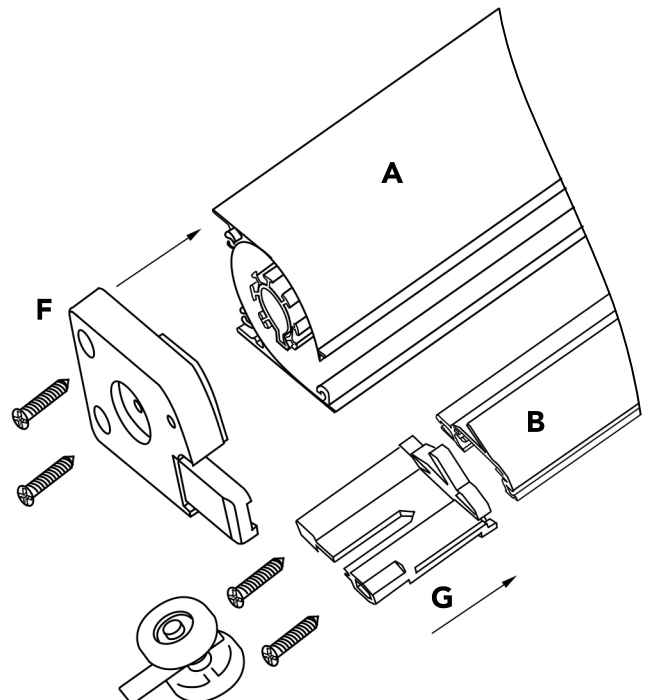

5 TENSION ADJUSTMENT

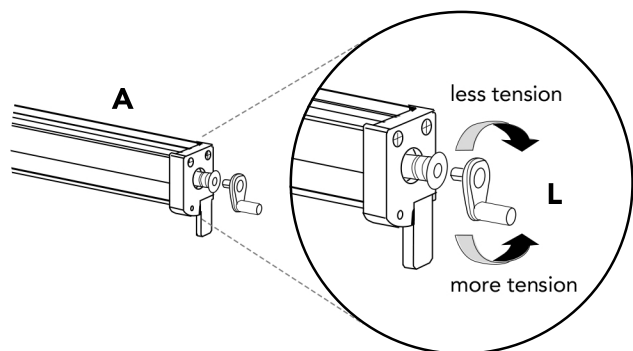

Once installed in the window, test the retraction rate.

To change the retraction rate, use the provided tensioner tool and insert it into the hex socket on the end of the cassette.

To **increase** the retraction rate, turn the tensioner tool **anti-clockwise** 1 to 4 rotations at a time and re-test.

To **decrease** the retraction rate, first turn the tensioner tool anti-clockwise to unlock it. Keeping a firm grip on the cassette and tool, turn the tool **clockwise** 1 to 4 rotations at a time, pushing the socket back into the cassette to lock, being careful not to let the hex socket slip off the tool.

6 FASTENING CASSETTE

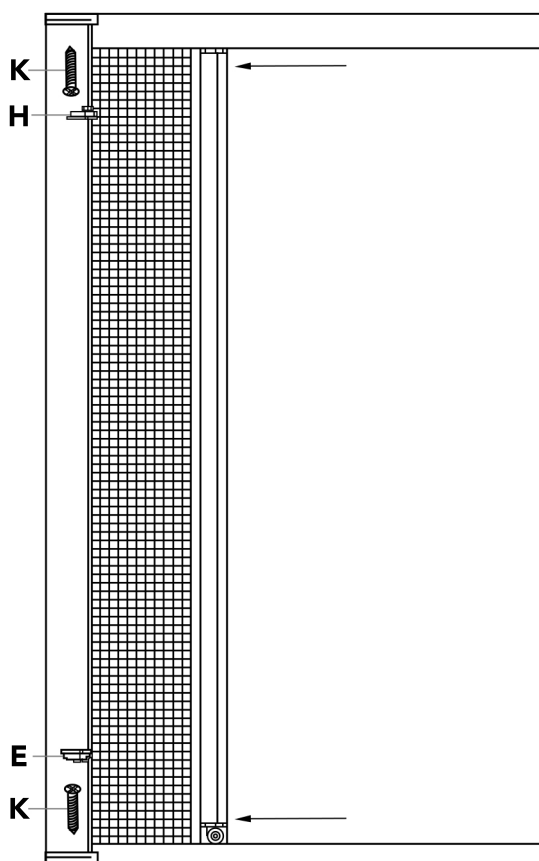

7 SLIDING BOTTOM AND TOP TRACKS INTO CASSETTE

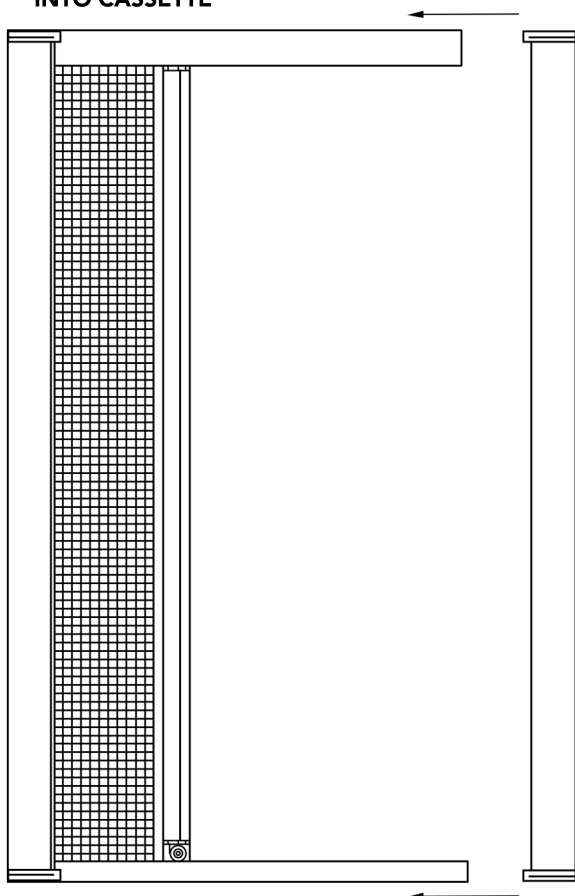

8 FASTENING TRACKS

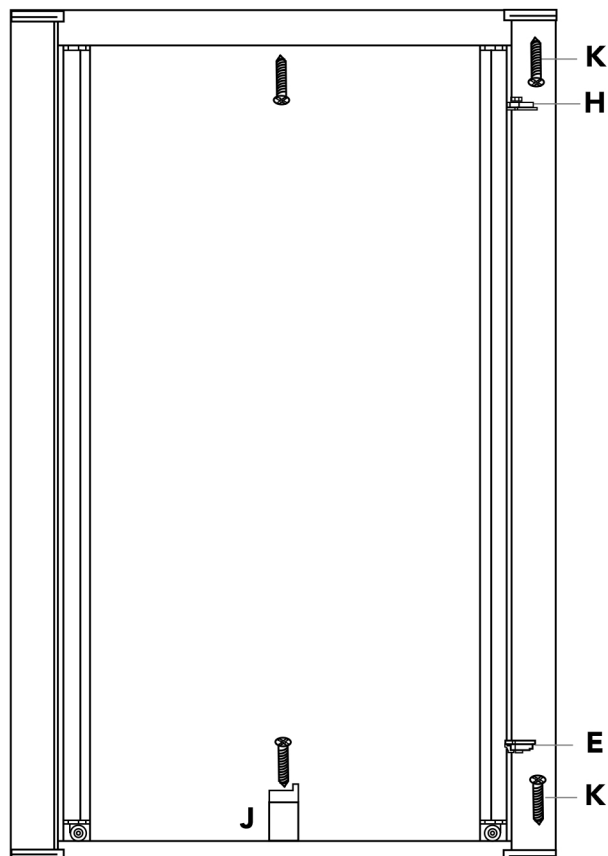

DOUBLE SCREEN KIT DIMENSIONS

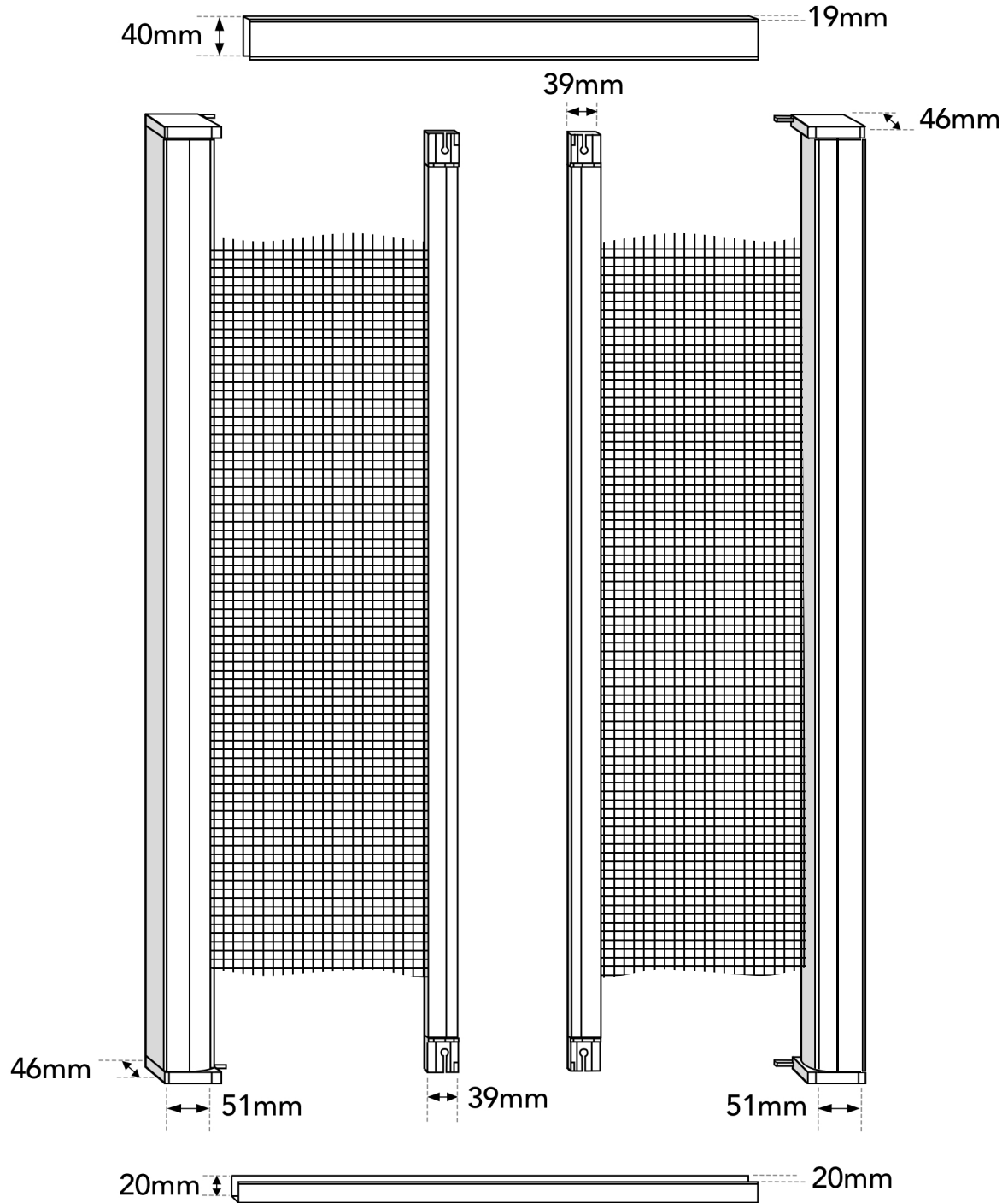

Please watch EZY Screens installation video on our website:

ezyscreens.com.au