

REVISIONS			
REV.	DESCRIPTION	DATE	APPROVED
A	INITIAL RELEASE	17/01/2019	C. SUTHERLAND

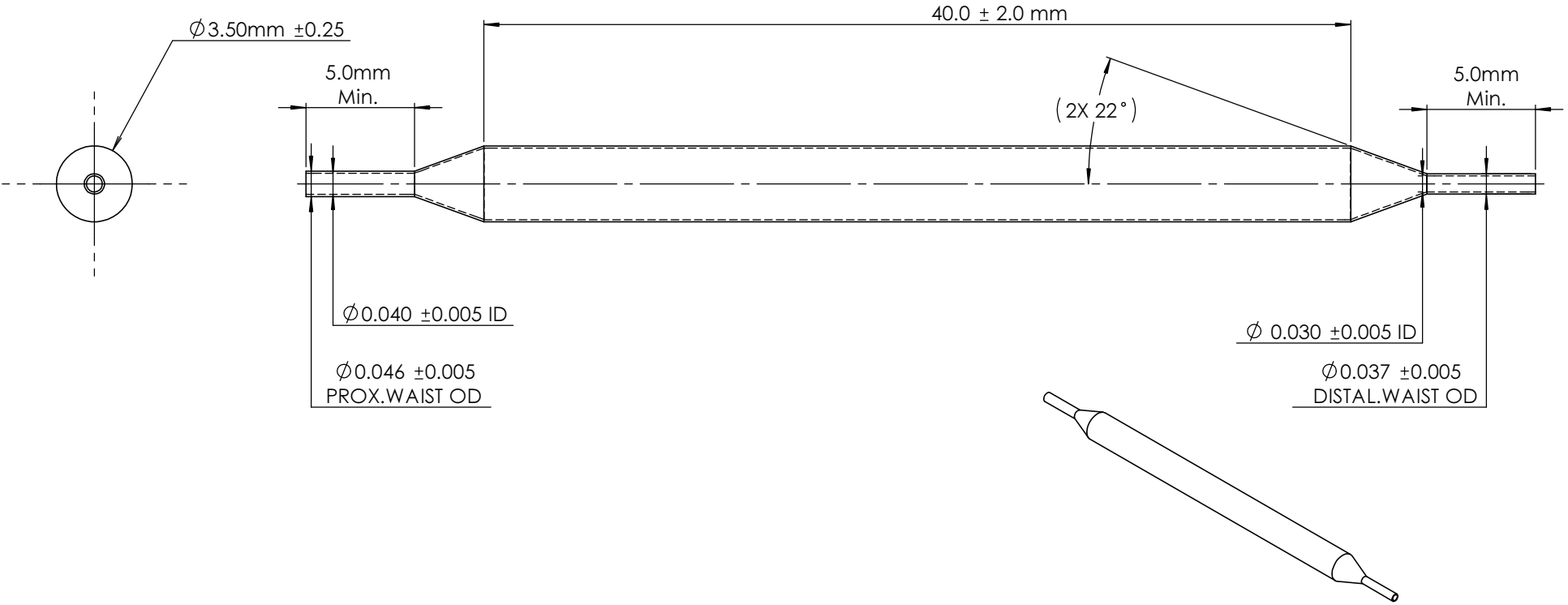

- MATERIAL: CARE ML21.
- BALLOONS ANNEALED FOR 1 HOUR AT 60C.
- VISUAL INSPECTION: FREE OF VISUAL DEFECTS, FISHEYES AND GELS, NO PARTICALS GREATER THAN 0.5MM WHEN INSPECTED AT 12"-18" FROM EYE (100% VISUAL INSPECTION).
- DIMENSIONAL INSPECTION:
 - WALL THICKNESSES TO BE MEASURED WITH DROP GAUGE.
 - LEG ID TO BE MEASURED WITH PIN GAUGES.
 - LEG OD TO BE MEASURED WITH DROP GAUGE USING PIN GAUGE IN LEG ID TO PREVENT COMPRESSION.
- COMPLIANCE AND PERFORMANCE TESTING:
 - BALLOON LENGTH TO BE MEASURED AT 0ATM WITH RULER +/-0.25MM.
 - COMPLIANCE AND OD TO BE MEASURED WITH HBLT MODEL 1000 IN WATER @37C.
 - RATED PRESSURE AND AVERAGE BURST PRESSURE MEASURED WITH HBLT MODEL 1000 IN WATER @37C.
 - PRODUCT NOT TO EXCEED THE RATED BURST PRESSURE (95%-99%) WITH AN AQL OF 1.0.
- PACKAGING:
 - PRODUCT WILL BE DOUBLE PACKED LABEL INFORMATION ON INNER PACK.
 - PACKAGE WILL DISPLAY MANUFACTURERS LOT NUMBER, QUANTITY AND PART NUMBER.

RBP @ 99.9% RELIABILITY/ 95% CONFIDENCE	25.6 ATM
AVERAGE BURST PRESSURE	32.1 ATM
NOMINAL PRESSURE	8.0 ATM

NAME	SIGNATURE	DATE		
DRAWN	B. Phelan	17/01/2019		
CHK'D	C. Sutherland	17/01/2019		
UNLESS OTHERWISE SPECIFIED: DIMENSIONS ARE IN MILLIMETERS			MATERIAL: CARE ML21	PROJECT: ONLINE STORE
			FINISH: Textured Finish	TITLE: 3.5x40mm TEXTURED BALLOON
				DWG NO. AME-N12-TB3540
				SHEET 1 OF 1
				REVISION A