

ITEM NO.	V/M PART NUMBER	DESCRIPTION	MATERIAL	QTY.
1	60055	ISO SPIKE FOR 4.1MM OD AND 4.8MM ID TUBING	ABS, WHITE - HI 121 H BY LG CHEMICAL.	1
2	20385	VENTED SPIKE COVER, WHITE	RESIN: PE RIBLENE FH 20 (RESIN) / COLORANT: 11060 WHITE	1

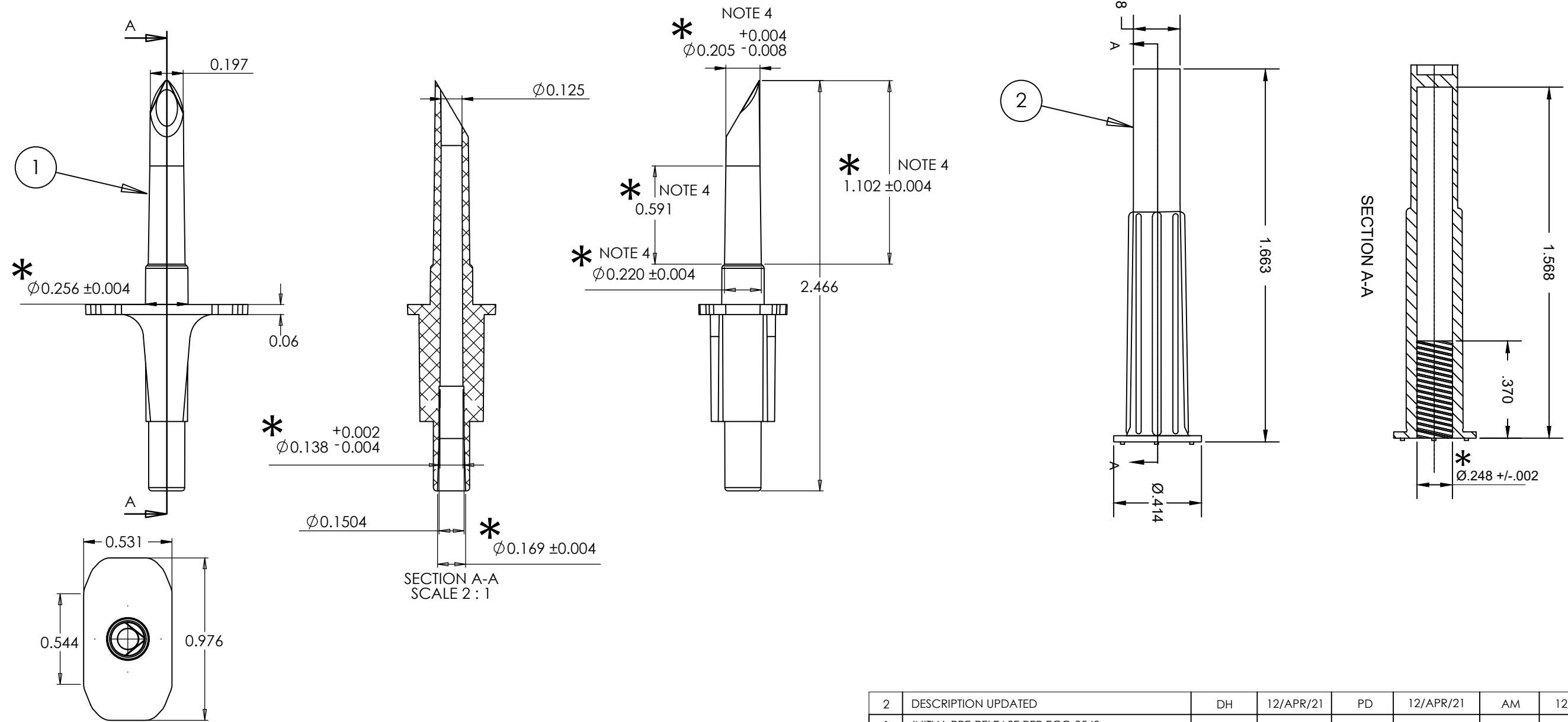

NOTES:

1. MATERIAL: SEE BOM.
2. VENDOR MUST CERTIFY EACH SHIPMENT THAT EACH SHIPMENT IS TRACEABLE TO VENDOR'S LOTS AND VENDORS SUPPLIER(S) LOTS.
3. MATERIAL MUST BE COMPATIBLE WITH ETO & GAMMA STERILIZATION.
4. MEETS ISO 8536-4.
5. FLASH: NOT TO EXCEED .012" IN CONNECTING AREAS. NOT TO EXCEED .020" IF CAN AFFECT PACKAGING
6. ALL DIMENSIONS ARE FOR REFERENCE ONLY UNLESS OTHERWISE SPECIFIED. (*) INDICATE CRITICAL DIMENSION.
7. BULK PACKAGING USING DOUBLE POLYVINYL BAGS.

REV	DESCRIPTION	DRAWN	DATE	CHKD	DATE	APP'D	DATE
2	DESCRIPTION UPDATED	DH	12/APR/21	PD	12/APR/21	AM	12/APR/21
1	INITIAL PRE-RELEASE PER ECO 2549	DH	05/FEB/20	PD	07/FEB/20	AM	07/FEB/20

REVISION HISTORY

DRAWING SPECIFICATIONS:
UNLESS OTHERWISE NOTED

DIMENSIONS ARE IN INCHES
BREAK ALL SHARP EDGES
CORNER RADIUS = N/A
SURFACE FINISH = N/A
TOLERANCES:
ANGLES = $\pm x^\circ$
X.XX = $\pm .xx$
X.XXX = $\pm .004$

THIS DRAWING IS PROPRIETARY OF VITALMED, INC. REPRODUCTION OR USE WITHOUT WRITTEN AUTHORIZATION IS PROHIBITED.

VITALMED, INC.

DESCRIPTION: ISO SPIKE WHITE, FOR 4.1mm OD AND 4.8mm ID TUBING, WITH COVER

MATERIAL: SEE NOTES	DRAWING TEMPLATE: F088 REV 0	SCALE: NONE	DWG NO: 70135	REV: 2
FINISH: NONE		SHEET: 1 OF 1		