



Streamline

WALL MOUNT

Installation Instructions, Maintenance, Use, and Warranty

S-100MSH-30
S-101MSH-36
S-120MSH-30
S-121MSH-36
S-140MSH-30
S-160MSH-30
S-161MSH-36
S-260MSH-30
S-100-WSBFL-30
S-101-WSBFL-36
S-120-WSBFL-30
S-121-WSBFL-36
S-140-WSBFL-30
S-160-WSBFL-30
S-161-WSBFL-36
S-260-WSBFL-30

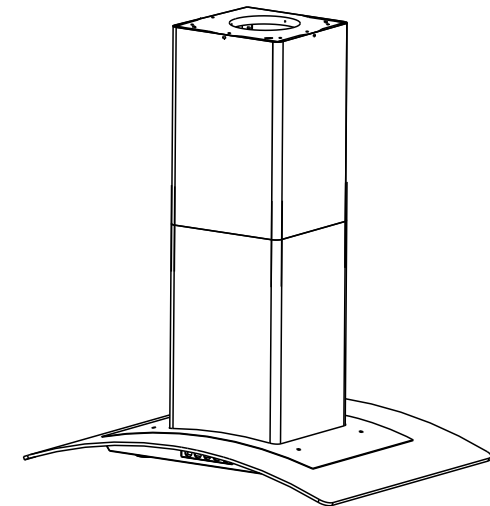

Streamline



Intertek

IMPORTANT: READ AND SAVE THESE INSTRUCTIONS.
FOR RESIDENTIAL USE ONLY.

Disclaimer: Item purchased may be slightly different from the manual.

A

WARRANTY, RETURNS, & DELIVERY INSTRUCTIONS

3 Year Manufacturer's Parts Warranty

This model comes with a 3-year manufacturer's parts warranty. We will provide free of charge replacement parts for the components that failed due to manufacturing defects. The customer must contact Streamline & provide a description of the issue as well as photos & proof of purchase. If a replacement unit is needed, this will be determined at Streamline's sole discretion. If in fact it is needed, then shipping will be paid for by the customer. The customer is also responsible for replacement part shipping costs. The following parts are not covered by this warranty:

- Lightbulbs
- Metal, aluminum, & charcoal filters

The following is not covered by our warranty:

- Improper maintenance
- Normal wear and tear
- Damage due to accidents, misuse or improper installation
- Use of arsenic products
- Non-reported freight damage
- Deterioration of the appearance of the product or any cosmetic issues such as scratches, chips, rust
- Damage resulting from unauthorized replacement parts or improper modifications

Streamline is released from all liability due to indirect, consequential, or incidental damages.

All parts & finishes of Streamline range hoods are warranted to the original purchaser & to be free from defects in material & workmanship. Labor charges and/or damage incurred in installation, repair, or replacement as well as any other kind of loss or damages are excluded. This warranty is valid in the United States and is non-transferrable.

Any applicable implied warranties, including the warranty of merchantability are limited in duration to a period of express warranty as provided herein beginning with the date of original purchase at retail and no warranties, whether express or implied shall be applied to this product.

This warranty does not extend to commercial or institutional use or installation.

Returns

We thank you for your purchase. Here at Streamline®, our goal is to provide customers with exceptional bathroom and kitchen products. We understand that things sometimes don't work out. If you are unsatisfied with your Streamline® product and would like to initiate a return, please reachout to support@streamlinebath.com.

We continue to grow and want to offer the best customer experience possible, and by reaching out to us prior to initiating a return, we can ensure that these issues do not continue in the future.

Deliveries

Immediate inspection is required when receiving Streamline® items. It is important to notate any damage or carton count discrepancy on the BOL / Proof of Delivery (POD) receipt when you sign for the delivery, even if the package appears only slightly damaged. If the driver doesn't allow or won't wait, notate on the BOL / POD "Driver will not allow inspection." Damages should be reported to Streamline® within 3 calendar days of delivery. Customers who sign for delivery and do not provide proper detailed description assume responsibility if merchandise is damaged or missing cartons. If the product itself appears significantly damaged, you may refuse delivery after you notate it on the POD / BOL and provide clear pictures to Streamline®. Please notify Streamline® of refusal so we can anticipate the return and send out a new item.

Please look for the following when checking:

- Carton/Pallet Count
- Crumpled and pushed in areas
- Fork lift punctures
- Holes
- Any additional outside damage to packaging

Damages & Refusing a Freight Shipment

If the shipment is damaged, a customer has the option of refusing the shipment. Contact our customer service representative immediately at support@streamlinebath.com when and if you refuse a shipment. Also, proper notation must be on the BOL / POD receipt. Any external evidence of loss or damage that occurred during transit is considered visible loss or damage and must be noted on the BOL / POD and signed by the carrier's agent (driver). Failure to adequately describe the visible loss or damage could result in the carrier delaying or refusing to honor the freight claim. Any damage that occurred during transit that was not visible at the time of delivery is considered concealed loss or damage. Due to rough handling in transit it is possible to damage the contents of a carton without damaging the outer packaging itself.

If such a situation occurs, it is important to contact Streamline® immediately for instructions on how to handle this. You must open all received boxes and inspect products for concealed damage within 72 hours (3 calendar days) of delivery and Streamline® must be notified at that time. After this time frame claims may not be honored. Streamline® reserves the right to replace any damaged merchandise within 3 calendar days of notification by the customer. If a replacement item is available for shipping within that time period, then a refund cannot be issued.

If no replacement is available, the damaged item(s) will be refunded in full if the damage was the fault of freight carrier, and all return procedures were followed. Failure to follow return procedure for the damaged item may result in a charge for the free replacement item.

B

MOUNTING INSTRUCTIONS

HARDWARE LIST

KEY	QTY	DESCRIPTION
A	x2	ST 2.9X10 SMALL SCREWS
B	x6	M4X40 LONG SCREWS
C	x6	DRYWALL ANCHOR (8mm)
D	x4	M4X8 SCREWS



PARTS LIST

KEY	QTY	DESCRIPTION
E	x2	UPPER BRACKET
F	x6	LOWER BRACKET
G	x6	CHIMNEY EXTENSION
H	x4	CHIMNEY COVER
I	x2	FLEXIBLE DUCT EXHAUST HOSE
J	x6	HOSE CLAMP (S-260-WSMF-30 Only)
K	x6	GLASS
L	x4	RANGE HOOD

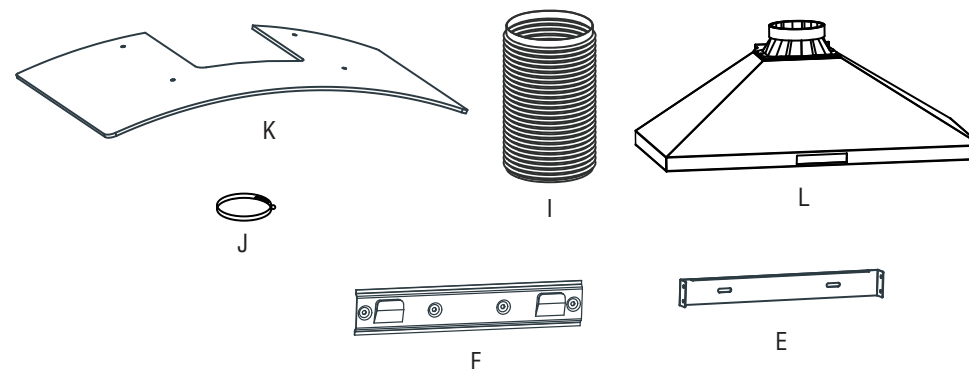
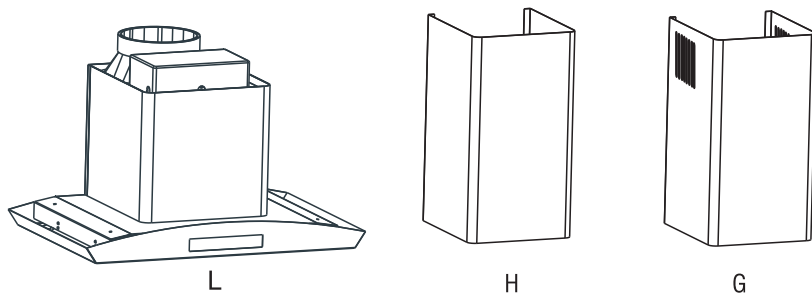

PARTS NOT SUPPLIED

- Duct tape
- Preinstalled ventilation system and ductwork
- Preinstalled outside duct cap or weatherproofing

INSTALLING THE RANGE HOOD

This installation is for mounting the product to a wall. Ensure your wall has the proper support to hold the range hood weight.

1. Begin installation by removing the filters and removing any tape on the air flow flappers.
2. Remove the protective film from the range hood and ducting. When handling the ducting, please wear protective gloves to avoid sharp edges.
3. If your model has an electronic touch sensor control panel, remove the protective plastic film covering the control panel.
4. Rest the lower bracket(F) against the wall at a height from the cooktop determined by the sum of the distance X+26"-28" (pictured below)

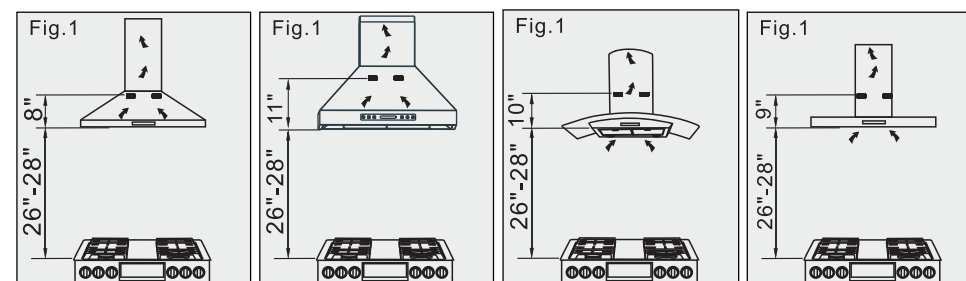

5. Check the horizontal alignment with a spirit level and mark the four holes to be drilled (1). Drill the holes, insert four 8mm drywall anchors (C), and fasten the lower bracket using four M4X40 long screws (B).

6. Having found the optimum position, rest the upper bracket (E) against the wall, and check the horizontal alignment using a spirit level. Mark the two holes to be drilled at the ends. Drill the holes (2), insert two 8mm drywall anchors (C), and fasten the upper bracket (F) using two M4x40 long screws (B).

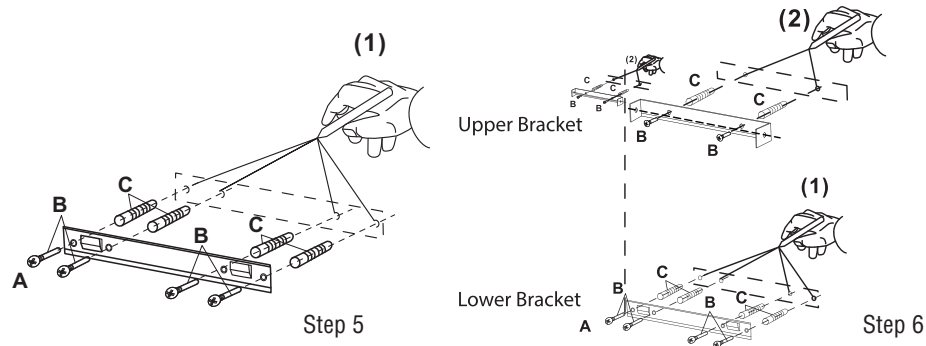

7. Step 7 applies to the following models: S-100-WSMF-30, S-101-WSMF-36, S-120-WSMF-30, S-121-WSMF-36.

WARNING: Before following this step, ensure that the glass canopy is completely free of damage. DO NOT install if it is damaged, even if the damage is very minor.

With a screw driver, remove the four screws installed on top of the main body of the range hood and set them aside. Carefully place the glass canopy on top of the main body. Then, secure the glass canopy to the main body using the same four screws that were removed earlier.

WARNING: DO NOT OVERTIGHTEN THE SCREWS. The screws should be snug, and no tighter than that. Overtightening the screws may damage or even shatter the glass over time.

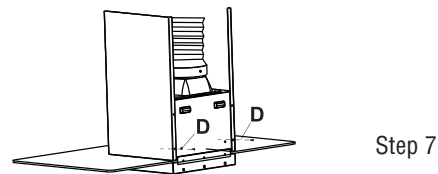

8. Install the round flexible duct exhaust hose (I) to the round vent air flap, and secure with two small screws (A) and tape or hose clamp and tape. Note: If you are choosing the ductless/recirculating model do not install the duct exhaust hose.

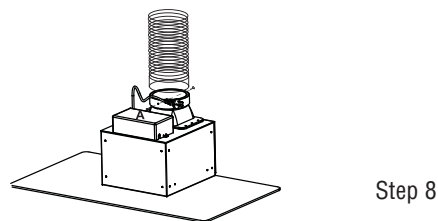

9. For Model S160, S-161, S260: Take the chimney cover (H) and find the holes on each lip. These are located at the bottom of the chimney cover, so ensure that the chimney cover is the right side up. Fit the chimney over onto the range hood main body. The holes on each lip should align with the holes found on the main body. Then, secure the chimney cover to the main body with two M4X8 screws (D).

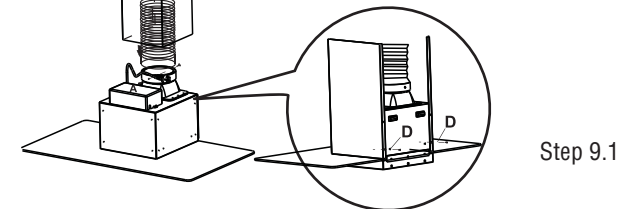

For Model S-100, S-101, S-120, S121, S-140: Insert the chimney cover (H) into the groove between the stainless-steel canopy and the range hood main body. The chimney cover does not need to be secured in place.

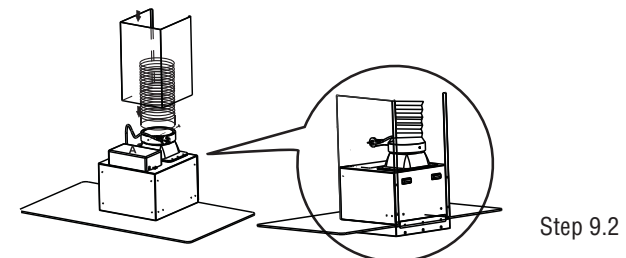

10. Place the chimney extension (H) inside the chimney cover (H). The end with the vent slits should be on top. For Model S-100, S-101, S-120, S121, S-140: Insert the chimney cover (H) into the groove between the stainless-steel canopy and the range hood main body. The chimney cover does not need to be secured in place.

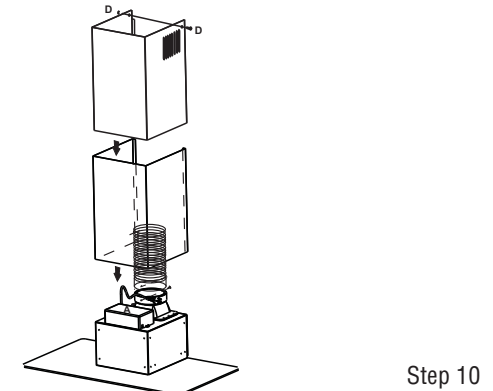

11. Slip inner duct up (J) through the support frames and over the ceiling mount bracket. Be sure the duct slides over the (4) mounting holes on each side.

12. The duct should cover the (4) mounting holes on the sides of the ceiling bracket. Screw in (4) M4X8 screws (C) through the predrilled holes in duct work into the (4) mounting holes.

13. Connect the upper end of the flexible duct exhaust hose (I) to your vent opening. (For ductless installation, skip to Step 14)

14. Being very careful of the sharp edges, raise the chimney extension (G) towards upper bracket (E) and extend it fully so that the upper bracket is completely covered. Secure the chimney extension in place with two M4x8 screws (D).

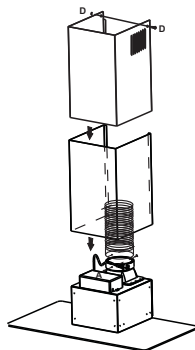

Step 14

15. Install the round flexible duct exhaust hose to the round vent air flap, and secure with (2) ST2.9X10 small screws(B) and tape or a hose clamp and tape.

C OPERATION

FIVE FINGER TOUCH BUTTON CONTROL PANEL

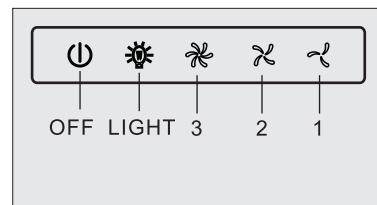

LIGHT BUTTON

Touch once: the light turns on
Touched again: the light turns off.

MOTOR BUTTON: 1, 2, 3

1: start the motor at minimum speed
2: start the motor at medium speed
3: start the motor at maximum speed

OFF

Touch once: stops the motor after 2-3 minutes and shows a flickering light

Touch twice: stops the motor immediately.

SIX FINGER TOUCH BUTTON CONTROL PANEL

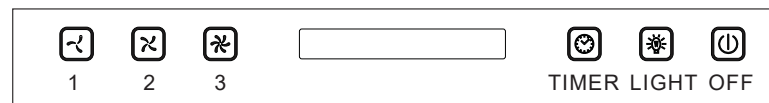

- **Turn on the power:** The buzzer will buzz, indicating the lights are on. Time will show 12:00. If no options are selected, then the range hood will turn off automatically. In order to continue operation, select a button.
- **Adjust time:** Turn the power on. The buzzer will buzz, indicating the lights are on. Touch and hold the TIMER button for 3 seconds. The time will start flickering and you will be able to set the correct time. Adjust the time by touching the 2 & 3 button and the timer button.
- **OFF:** Shuts off the power
- **LIGHT:** Turn the lights on or off
- **TIMER:** Turn off power within 2 minutes

D MAINTENANCE AND CLEANING

Constant maintenance ensures the correct operation and efficiency of the appliance over time. Special attention should be paid to the grease-trapping filters and the charcoal filters. Frequent cleaning of the filters will ensure that fats and grease do not accumulate on the cooker hood, with the consequent risk of fire.

1. METAL GREASE-TRAPPING FILTERS

These trap the fat and grease particles suspended in the air, and therefore should be washed every month in hot water and detergent. **DO NOT BEND.** Wait until they are completely dry before repositioning them. The metal filters can be cleaned in a dishwasher.

2. CHARCOAL FILTERS

These trap odors present in the stream of air that passes through them. The air is purified by passing a number of times through the filters and then recirculated into the kitchen. The charcoal filters cannot be cleaned, and should be replaced on average 3-4 months (according to use).

3. CLEANING THE OUTSIDE OF THE APPLIANCE

The outside of the cooker hood should be cleaned using a damp cloth and neutral liquid detergent or denatured alcohol.

Do not use products that contain abrasive substances, rough cloths or cloths not specifically designed for cleaning steel.

Using abrasive substances or rough cloths will inevitably damage the finish of the steel. The steel surface will be irrevocably damaged if the instructions above are not complied with. Keep these instructions together with the instructions for use of your hood.

The manufacturer accepts no liability for any damage caused by non-compliance with the instructions above.

4. CLEANING THE INSIDE OF THE APPLIANCE

The electrical parts or parts of the motor assembly inside the range hood must not be cleaned using liquids or solvents.

E

SAFETY DISCLAIMER

- Read all instructions before installing and operating this appliance. This instruction booklet must be kept together with the appliance for future reference. If the appliance is sold or consigned to other parties, please ensure that the booklet is supplied with it in order to ensure that the new user has the correct information on the operation of the range hood and aware of the warnings.
- The manufacturer disclaims all liability for any damage that may be directly or indirectly caused to people, things, and animals due to the failure to follow all the instructions provided in this booklet and above all the warnings relating to the installation, operation, and maintenance of the appliance.
- These warnings have been provided for your safety and the safety of others. As a result, please read them carefully before installing and operating the appliance.
- The installation instructions in this manual is intended for qualified installers, service technicians or persons with similar qualified background.
- It is dangerous to modify or attempt to modify the characteristics of this system. In the event of malfunctions or if repairs are required to the appliance, do not attempt to solve the problems directly.
- Only qualified professionals should proceed with installation and electrical wiring. All installation and wiring must be done with regard to any applicable codes and standards.
- DO NOT attempt to install this appliance yourself.
- Repairs performed by unqualified persons may cause damage. For all questions on repairs and other work on the appliance, please contact support@streamlinebath.com
- If the supply cord is damaged, it must be replaced by the manufacturer in order to avoid a hazard. Any modifications that may be required to the electrical system for the installation of the cooker hood must only be made by qualified electricians.
- Before performing any cleaning or maintenance operations, disconnect the appliance by unplugging it or using the main switch.
- Always check that the electrical parts are off when the appliance is not being used.
- The range hood must only be used for the exhaust of cooking fumes in the home. The manufacture disclaims all liability for any other use of the appliance. The maximum weight of any object placed above the hood (or hung to) must not exceed 3.3 lbs.
- This range hood may NOT be used to exhaust hazardous materials.
- This appliance is not intended for use by young children. Young children should be supervised to ensure they do not play with the appliance.
- Prior to removing any parts from the range hood, please ensure that you wear protective gloves. The range hood may have very sharp edges.
- Do not connect the appliance to flues (from boilers, fireplace, etc.). Make sure the mains voltage corresponds to the values on the rating plate located inside the cooker hood. The minimum safety distance between the cooktop and the cooker hood must be at least 26 in.
- Check deep-fryers during use: Superheated oil may be flammable.
- Ensure that there is adequate ventilation of the room when the range hood is used at the same time as appliances burning gas or other flues.
- The exhaust air must not be discharged into a flue which is used for exhausting fumes from appliances burning gas or other fuels.

- Ensure that all regulations concerning the discharge of exhaust air have been fulfilled before you use the appliance.
- Please follow all applicable safety standards and guidelines, such as those published by the NFPA, the American Society of Heating, and local codes.
- Proper airflow is needed for proper ventilation and exhausting of gases through the duct in order to prevent the gases returning into the home. When ducting the range hood, please ensure that you do not damage any hidden wiring or utilities.
- Ensure to clean old ductwork regularly to avoid a grease fire and proper operation.
- Make sure that the duct work is properly connected and secured to the range hood and outdoors.
- Regularly clean the range hood from any grease that has accumulated as it should not be allowed to accumulate on any surfaces or parts of the range hood.
- When cooking greasy foods or at high heat, always ensure that the highest settings are used on the range hood.
- Never cook on open flames under the range hood.
- Never leave food unattended when cooking on the highest settings. This may cause grease spillovers that can ignite.
- In the event of a stove top grease fire, smother the flame using a close fitting lid and never pick up the flaming pan.
- If the flames do not go out, call the fire department and do NOT use water or wet dishcloths. Avoid using flammable or combustible material from putting out the flame.

F

WIRING DIAGRAMS

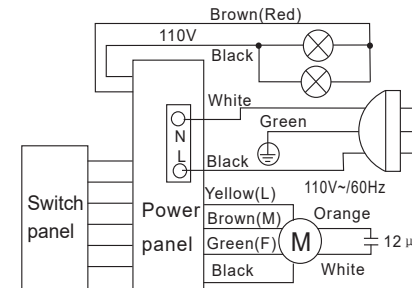

S-100MSH-30
 S-101MSH-36
 S-120MSH-30
 S-121MSH-36
 S-140MSH-30
 S-160MSH-30
 S-161MSH-36

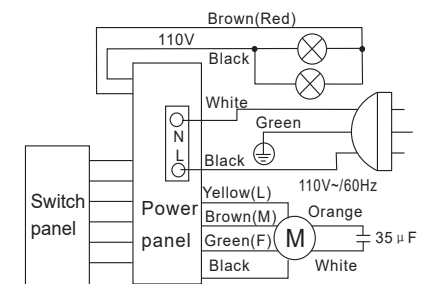

S-100-WSBFL-30
 S-101-WSBFL-36
 S-120-WSBFL-30
 S-121-WSBFL-36
 S-140-WSBFL-30
 S-160-WSBFL-30
 S-161-WSBFL-36

S-260MSH-30
 S-260-WSBFL-30