

**FRONT VIEW**

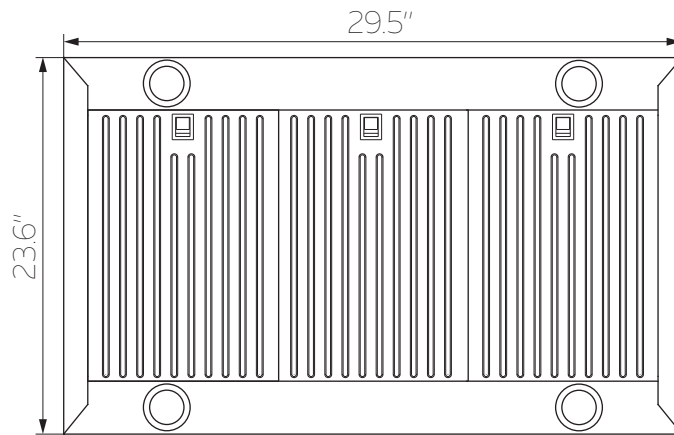

**VIEW FROM UNDER**

<b>Overall Dimensions</b>	30" W x 24" L x 22.1" H
<b>Installation Type</b>	Island
<b>Exhaust Method</b>	Convertible
<b>Material</b>	Stainless Steel

<b>Noise Level</b>	42-63dB(A)
<b>Min/Max CFM</b>	100-480
<b>Speed &amp; Control Type</b>	3 Speed Touch Pad
<b>Warranty</b>	3 Year Limited Warranty