

Safety First: This document provides all the necessary information to allow your Whelen product to be properly and safely installed. Before beginning the installation and/or operation of your new product, the installation technician and operator must read this manual completely. Important information is contained herein that could prevent serious injury or damage.

- Proper installation of this product requires the installer to have a good understanding of automotive electronics, systems and procedures.
- Whelen Engineering requires the use of waterproof butt splices and/or connectors if that connector could be exposed to moisture.
- Any holes, either created or utilized by this product, should be made both air- and watertight using a sealant recommended by your vehicle manufacturer.
- Failure to use specified installation parts and/or hardware will void the product warranty!
- If mounting this product requires drilling holes, the installer **MUST** be sure that no vehicle components or other vital parts could be damaged by the drilling process. Check both sides of the mounting surface before drilling begins. Also de-burr any holes and remove any metal shards or remnants. Install grommets into all wire passage holes.
- Do not install this product or route any wires in the deployment area of your air bag. Equipment mounted or located in the air bag deployment area will damage or reduce the effectiveness of the air bag, or become a projectile that could cause serious personal injury or death. Refer to your vehicle owner's manual for the air bag deployment area. The User/Installer assumes full responsibility to determine proper mounting location, based on providing ultimate safety to all passengers inside the vehicle.
- For this product to operate at optimum efficiency, a good electrical connection to chassis ground must be made. The recommended procedure requires the product ground wire to be connected directly to the **NEGATIVE (-)** battery post.
- If this product uses a remote device to activate or control this product, make sure that this control is located in an area that allows both the vehicle and the control to be operated safely in any driving condition.
- Do not attempt to activate or control this device in a hazardous driving situation.
- This product contains either strobe light(s), halogen light(s), high-intensity LEDs or a combination of these lights. Do not stare directly into these lights. Momentary blindness and/or eye damage could result.
- Use only soap and water to clean the outer lens. Use of other chemicals could result in premature lens cracking (crazing) and discoloration. Lenses in this condition have significantly reduced effectiveness and should be replaced immediately. Inspect and operate this product regularly to confirm its proper operation and mounting condition. Do not use a pressure washer to clean this product.
- **WARNING!** All customer supplied wires that connect to the positive (+) terminal of the battery must be sized to supply at least 125% of the maximum operating current and **FUSED** "at the battery" to carry that load. **DO NOT USE CIRCUIT BREAKERS WITH THIS PRODUCT!**
- **FAILURE TO FOLLOW THESE PRECAUTIONS AND INSTRUCTIONS COULD RESULT IN DAMAGE TO THE PRODUCT OR VEHICLE AND/OR SERIOUS INJURY TO YOU AND YOUR PASSENGERS!**

Mounting

IMPORTANT! BEFORE MOUNTING READ ALL THE ABOVE WARNINGS FOR MOUNTING, VEHICLE DAMAGE AND WIRE ROUTING.

Mounting Pattern

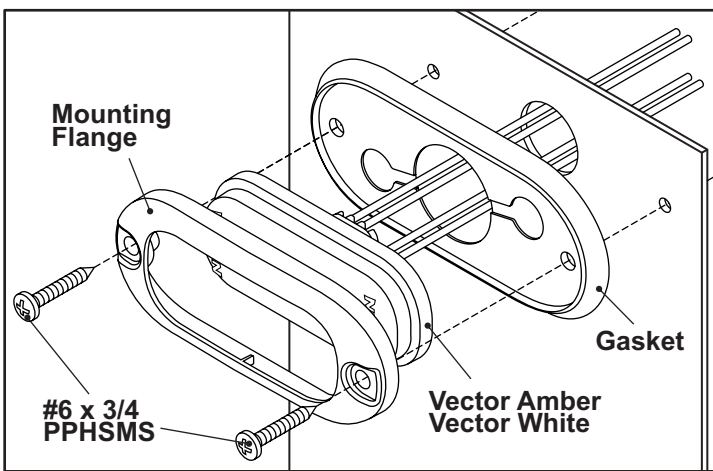
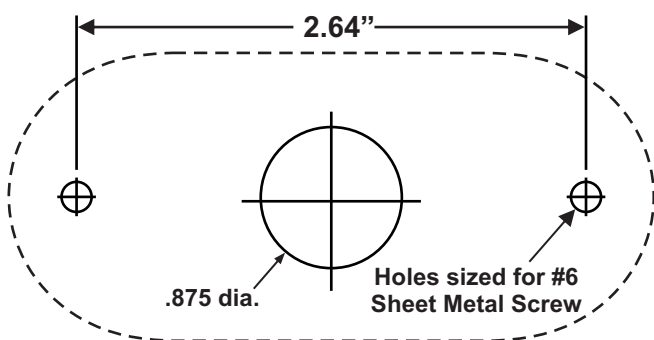

Hardware Mount

1. Using the mounting dimensions shown, mark the mounting and wire hole locations onto the proposed mounting surface.
2. Drill two mounting holes (sized for #6 sheet metal screws and the mounting surface thickness) and a .875" wire passage hole into the mounting surface. De-burr wire passage hole before proceeding.
3. Route the lighthead wires through the wire passage hole. Position the Vector onto its mounting location and place the mounting flange onto the Vector as shown.
4. Insert the two supplied #6 sheet metal screws through the flange mounting holes and into the mounting surface. Tighten the mounting screws until the lighthead assembly is drawn firmly against the mounting surface.
5. Using appropriately sized wires (minimum 22 AWG), extend the wires to their designated connections. Refer to the Wiring Diagram for wiring and fusing information.

Wiring Diagram

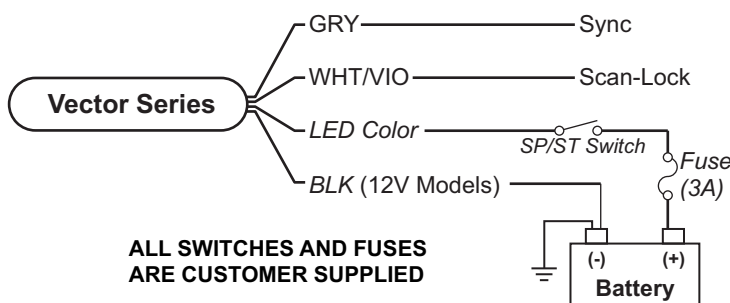

Ground (BLK) - Extend the BLK wire to Chassis Ground.

Warning Light (LED Color) - Extend the LED wire to +VBAT via an SP/ST switch. Fuse @ 3 AMPS.

SYNC (GREY) - To SYNC 2 lighthead, configure both lighthead to display the same Phase 1 (Simultaneous) pattern. Turn power off and connect the GREY wire from each lighthead together. Activate the lighthead and their patterns will be synchronized. To configure 2 lighthead to alternate their patterns, advance either lighthead to Phase 2 (Alternating) of the current pattern.

Scan-Lock™ (WHT/VIO) - Extend the WHT/VIO wire to +VBAT via a momentary switch (fuse @ 1 amp).

Scan-Lock Operation

Note: In order to change flash patterns, the lighthead must be on.

TO CHANGE PATTERNS: To advance to the next pattern apply +VDC to the WHT/VIO wire for less than 1 second and release. To cycle back to the previous pattern apply +VDC to the WHT/VIO wire for more than 1 second and release.

TO CHANGE THE DEFAULT PATTERN: When the desired pattern is displayed, allow it to run for more than 5 seconds. The lighthead will now display this pattern when initially activated.

TO RESTORE THE FACTORY DEFAULT PATTERN: This will reset all patterns back to their default settings. With the light turned off, apply power to the WHT/VIO wire. With power applied to the WHT/VIO wire, turn light on. Allow the unit to run for 3 seconds before removing power from the WHT/VIO wire.

Flash Patterns (SYNC)

- | | |
|------------------------------|----------------------------|
| 1. SignalAlert™ 75 / phase 1 | 14. PingPong™ 75 / phase 2 |
| 2. SignalAlert™ 75 / phase 2 | (Non-SYNC) |
| 3. CometFlash@ 75 / phase 1 | 15. SingleFlash 60 |
| 4. CometFlash@ 75 / phase 2 | 16. SingleFlash 90 |
| 5. DoubleFlash 75 / phase 1 | 17. SingleFlash 120 |
| 6. DoubleFlash 75 / phase 2 | 18. SingleFlash 300 |
| 7. SingleFlash 75 / phase 1 | 19. DoubleFlash 150 |
| 8. SingleFlash 75 / phase 2 | 20. ComAlert™ 150 |
| 9. ComAlert™ 75 / phase 1 | 21. ActionFlash™ 50 |
| 10. ComAlert™ 75 / phase 2 | 22. ActionFlash™ 150 |
| 11. LongBurst™ 75 / phase 1 | 23. ModuFlash™ |
| 12. LongBurst™ 75 / phase 2 | 24. ActionScan™ |
| 13. PingPong™ 75 / phase 1 | 25. Steady |

Waterproof butt splices and/or connectors are required if that connection could be exposed to moisture. Any unused wires must be sealed (waterproofed) to prevent moisture infiltration.