



WHELEN AEROSPACE TECHNOLOGIES

Phone: 1-772-276-6615

gse@flywat.com

51 Winthrop Road

Chester, CT 06412

Installation Guide:
Junior Executive Mini-Lightbar
Model: FLJXLB

Warnings to Installers

Whelen's emergency vehicle warning devices must be properly mounted and wired in order to be effective and safe. Read and follow all of Whelen's written instructions when installing or using this device. Emergency vehicles are often operated under high speed stressful conditions which must be accounted for when installing all emergency warning devices. Controls should be placed within convenient reach of the operator so that they can operate the system without taking their eyes off the roadway. Emergency warning devices can require high electrical voltages and/or currents. Properly protect and use caution around live electrical connections. Grounding or shorting of electrical connections can cause high current arcing, which can cause personal injury and/or vehicle damage, including fire. Many electronic devices used in emergency vehicles can create or be affected by electromagnetic interference. Therefore, after installation of any electronic device it is necessary to test all electronic equipment simultaneously to insure that they operate free of interference from other components within the vehicle. Never power emergency warning equipment from the same circuit or share the same grounding circuit with radio communication equipment. All devices should be mounted in accordance with the manufacturer's instructions and securely fastened to vehicle elements of sufficient strength to withstand the forces applied to the device. Driver and/or passenger air bags (SRS) will affect the way equipment should be mounted. This device should be mounted by permanent installation and within the zones specified by the vehicle manufacturer, if any. Any device mounted in the deployment area of an air bag will damage or reduce the effectiveness of the air bag and may damage or dislodge the device. Installer must be sure that this device, its mounting hardware and electrical supply wiring does not interfere with the air bag or the SRS wiring or sensors. Mounting the unit inside the vehicle by a method other than permanent installation is not recommended as unit may become dislodged during swerving; sudden braking or collision. Failure to follow instructions can result in personal injury. Whelen assumes no liability for any loss resulting from the use of this warning device. **PROPER INSTALLATION COMBINED WITH OPERATOR TRAINING IN THE PROPER USE OF EMERGENCY WARNING DEVICES IS ESSENTIAL TO INSURE THE SAFETY OF EMERGENCY PERSONNEL AND THE PUBLIC.**

Warnings to Users

Whelen's emergency vehicle warning devices are intended to alert other operators and pedestrians to the presence and operation of emergency vehicles and personnel. However, the use of this or any other Whelen emergency warning device does not guarantee that you will have the right-of-way or that other drivers and pedestrians will properly heed an emergency warning signal. Never assume you have the right-of-way. It is your responsibility to proceed safely before entering an intersection, driving against traffic, responding at a high rate of speed, or walking on or around traffic lanes. Emergency vehicle warning devices should be tested on a daily basis to ensure that they operate properly. When in actual use, the operator must ensure that both visual and audible warnings are not blocked by vehicle components (i.e.: open trunks or compartment doors), people, vehicles, or other obstructions. It is the user's responsibility to understand and obey all laws regarding emergency warning devices. The user should be familiar with all applicable laws and regulations prior to the use of any emergency vehicle warning device. Whelen's audible warning devices are designed to project sound in a forward direction away from the vehicle occupants. However, because sustained periodic exposure to loud sounds can cause hearing loss, all audible warning devices should be installed and operated in accordance with the standards established by the National Fire Protection Association.

Safety First

This document provides all the necessary information to allow your Whelen product to be properly and safely installed. Before beginning the installation and/or operation of your new product, the installation technician and operator must read this manual completely. Important information is contained herein that could prevent serious injury or damage.

⚠ WARNING: This product can expose you to chemicals including Methylene Chloride which is known to the State of California to cause cancer, and Bisphenol A, which is known to the State of California to cause birth defects or other reproductive harm. For more information go to www.P65Warnings.ca.gov.

- **Proper installation of this product requires the installer to have a good understanding of automotive electronics, systems and procedures.**
- **Whelen Engineering requires the use of waterproof butt splices and/or connectors if that connector could be exposed to moisture.**
- **Any holes, either created or utilized by this product, should be made both air- and watertight using a sealant recommended by your vehicle manufacturer.**
- **Failure to use specified installation parts and/or hardware will void the product warranty.**
- **If mounting this product requires drilling holes, the installer MUST be sure that no vehicle components or other vital parts could be damaged by the drilling process. Check both sides of the mounting surface before drilling begins. Also de-burr the holes and remove any metal shards or remnants. Install grommets into all wire passage holes.**
- **If this manual states that this product may be mounted with suction cups, magnets, tape or Velcro®, clean the mounting surface with a 50/50 mix of isopropyl alcohol and water and dry thoroughly.**
- **Do not install this product or route any wires in the deployment area of your air bag. Equipment mounted or located in the air bag deployment area will damage or reduce the effectiveness of the air bag, or become a projectile that could cause serious personal injury or death. Refer to your vehicle owner's manual for the air bag deployment area. The User/Installer assumes full responsibility to determine proper mounting location, based on providing ultimate safety to all passengers inside the vehicle.**
- **For this product to operate at optimum efficiency, a good electrical connection to chassis ground must be made. The recommended procedure requires the product ground wire to be connected directly to the NEGATIVE (-) battery post (this does not include products that use cigar power cords).**
- **If this product uses a remote device for activation or control, make sure that this device is located in an area that allows both the vehicle and the device to be operated safely in any driving condition.**
- **Do not attempt to activate or control this device in a hazardous driving situation.**
- **This product contains either strobe light(s), halogen light(s), high-intensity LEDs or a combination of these lights. Do not stare directly into these lights. Momentary blindness and/or eye damage could result.**
- **Use only soap and water to clean the outer lens. Use of other chemicals could result in premature lens cracking (crazing) and discoloration. Lenses in this condition have significantly reduced effectiveness and should be replaced immediately. Inspect and operate this product regularly to confirm its proper operation and mounting condition. Do not use a pressure washer to clean this product.**
- **It is recommended that these instructions be stored in a safe place and referred to when performing maintenance and/or reinstallation of this product.**
- **FAILURE TO FOLLOW THESE SAFETY PRECAUTIONS AND INSTRUCTIONS COULD RESULT IN DAMAGE TO THE PRODUCT OR VEHICLE AND/OR SERIOUS INJURY TO YOU AND YOUR PASSENGERS!**

IMPORTANT! The lightbar must be a minimum of 16" from any radio antennas.

NOTE: There may be a roof support member that spans the distance between the driver's and passengers side. **DO NOT DRILL THROUGH THIS MEMBER!** Adjust the location until the holes can be drilled without contacting this support member.

Caution: Permanent mounting of this product will require drilling. It is absolutely necessary to make sure that no other vehicle components could be damaged by this process. Check both sides of the mounting surface before starting. If damage is likely, select a different mounting location.

Permanent Mounting:

1. Install the mounting bracket to the mounting foot using the supplied 5/16 FLAT WASHERS and 5/16 - 18 ELASTIC STOP NUTS (Fig. 1). Do NOT install the optional spacers yet.
2. Place the bracket into the track on the bottom of the extruded base of the lightbar and twist it into position (Fig. 2).

Fig. 1

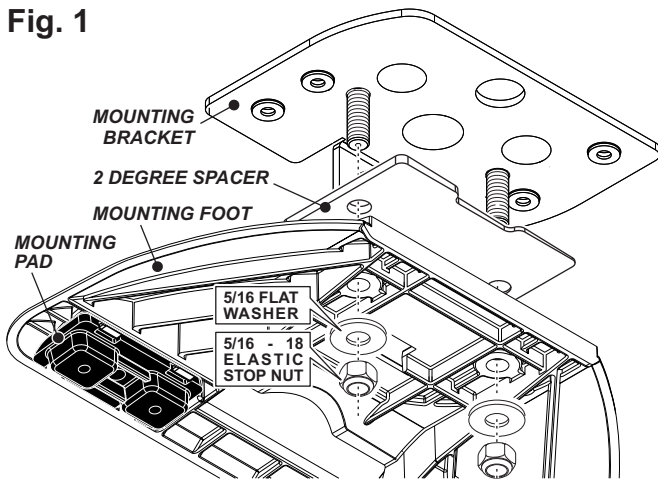

Insert round side of bracket under lip in extrusion

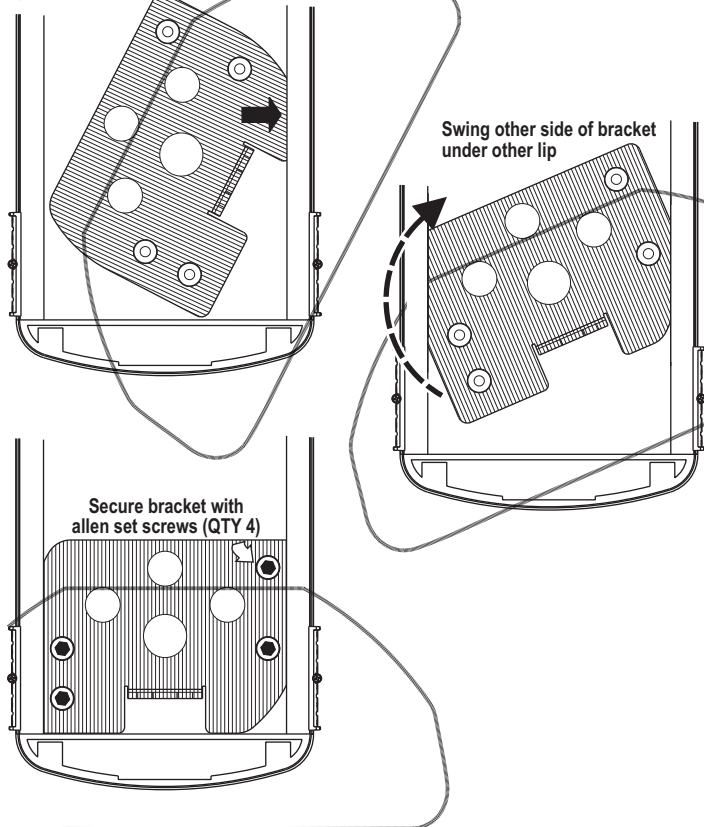
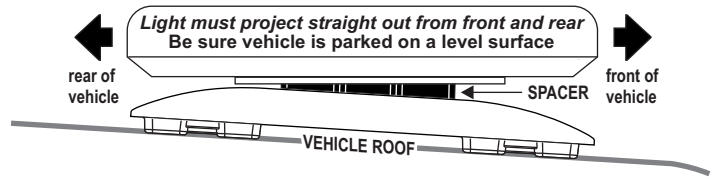
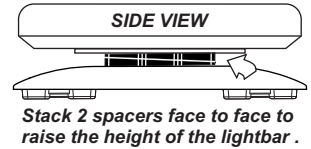

Fig. 2

3. Slide the bracket to the outer end of the base extrusion and secure the bracket to the extrusion using the four 1/4 - 20 X 1/2 ALLEN SET SCREWS (Fig. 2). Repeat steps 1 - 3 for other side of lightbar.
4. **Installing Spacers:** Spacers are used as required to adjust the lightbars clearance from the vehicle roof. Spacers are also used to make the lightbar level with the road so that the light does not project up or down when viewed from the front or rear of the vehicle. Each spacer creates a 2° incline.



Lightbar angle: Place the lightbar onto the vehicle roof in its exact mounting location and use a level to check the angle of the lightbar. If (because of the curvature of the vehicle roof) the front and rear lights project up or down, you will need to install one of the supplied spacers. Note the angle of the tilt to determine where to place the spacer.



Installation: Remove the mounting feet (not the bracket) and install the spacer (maximum 1 per side) then reinstall the feet.

Distance from roof: The lightbar must be no closer than 1/2 inch (at the closest point) from the vehicle roof. **Installation:** Remove the mounting feet (not the bracket), install the spacers as shown (maximum 2 per side) and reinstall feet.

5. Position the lightbar onto the vehicle in its exact mounting location and mark the location of the mounting holes onto the mounting surface using the mounting feet as templates. If the permanent mounting holes in the mounting feet are difficult to access, you can use the measurements shown here to mark off and drill the mounting holes. You

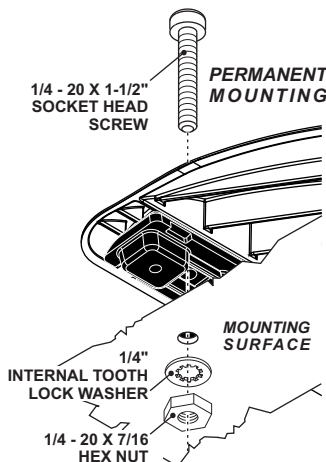
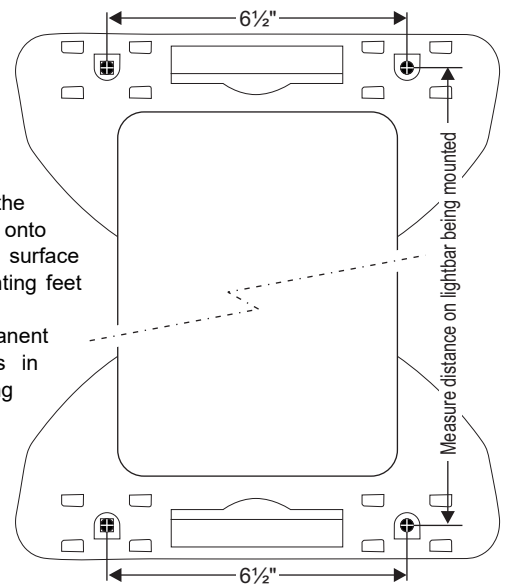

- will also need to measure the distance between the mounting feet for your application since lightbar width will depend on the lightbar you are mounting.
6. Remove the lightbar and drill the 4 mounting holes.
 7. Install the lightbar using the supplied 1/4 - 20 X 1-1/2" Socket Head Screw, 1/4" Internal Tooth Lock Washer and 1/4 - 20 X 7/16 Hex Nut.

Wiring and Operation:

Extend the control cable to your switch panel and make connections. The control cable connects to your control head or switch box and is fused there. Applying +12VDC to a control wire will activate its function. BLACK and WHT/BLK are ground wires.

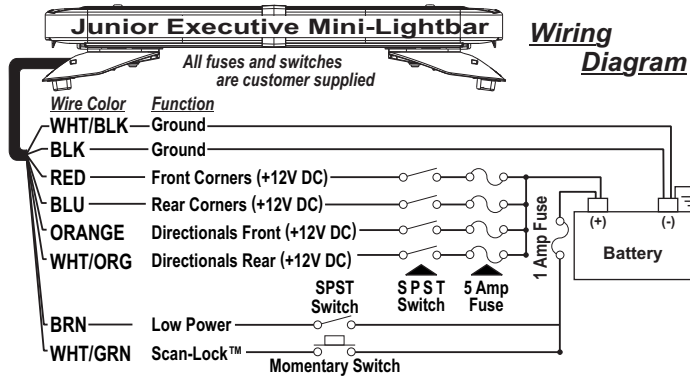

RED / Front Corners:

Apply +12VDC to the RED wire to activate the *Front Corners* lights.

BLUE / Rear Corners:

Apply +12VDC to the BLUE wire to activate the *Rear Corners* lights.

ORANGE / Front Directionals:

Apply +12VDC to ORG wire to activate the *Front Directional* lights.

WHT/ORG / Rear Directionals:

Apply +12VDC to WHT/ORG wire to activate the *Rear Directional* lights.

BROWN / Low Power:

The switch type used depends on how you wish *Low Power* to function:
Latching Mode: Apply +12 VDC to the BROWN wire for less than 1 sec. to "latch" the lightbar into *Low Power*. The unit must be turned off and then back on to restore normal operation. (Momentary Switch)

Level Mode: Apply +12 VDC to the BROWN wire for over 1 sec. to hold the lightbar in *Low Power* until voltage is removed. (Toggle Switch)

WHITE-GREEN / Scan-Lock™:

The WHT/GRN wire is for Scan-lock pattern selection. On cigar plug models use the switch on top of the cigar plug instead of the WHT/GRN wire. You must activate the function to select a pattern for it:

TO CYCLE THROUGH ALL PATTERNS:

To cycle forward apply +12 VDC to the WHT/GRN wire for less than 1 second and release.
To cycle backward apply +12 VDC to the WHT/GRN wire for more than 1 second and release.

TO SET A PATTERN AS DEFAULT:

When the pattern is displayed, allow it to run for more than 5 seconds. The lighthead will now display this pattern when activated.

TO RESET TO THE FACTORY DEFAULT PATTERN:

With power off, apply +12 VDC to WHT/GRN wire while turning power on.

Use a normally open momentary switch for Scan-Lock operation

FLASH PATTERNS:

- | | | |
|------------------------------|-------------------------------|-------------------------------|
| 1. SignalAlert™ L/R SYNC | 23. LongBurst™ IN/OUT | 46. SingleFlash 120 ALT/SIM |
| 2. SignalAlert™ L/R ASYNC | 24. LongBurst™ SIM | 47. SingleFlash 120 STDY LEFT |
| 3. SignalAlert™ IN/OUT | 25. LongBurst™ ALT/SIM | 48. SingleFlash 120 STDY RT |
| 4. SignalAlert™ SIM | 26. SingleFlash 60 L/R SYNC | 49. SingleFlash 120 STDY BOTH |
| 5. SignalAlert™ ALT/SIM | 27. SingleFlash 60 L/R ASYNC | 50. SingleFlash 240 L/R SYNC |
| 6. CometFlash® L/R SYNC | 28. SingleFlash 60 IN/OUT | 51. SingleFlash 240 L/R ASYNC |
| 7. CometFlash® L/R ASYNC | 29. SingleFlash 60 SIM | 52. SingleFlash 240 IN/OUT |
| 8. CometFlash® IN/OUT | 30. SingleFlash 60 ALT/SIM | 53. SingleFlash 240 SIM |
| 9. CometFlash® SIM | 31. SingleFlash 60 STDY LEFT | 54. SingleFlash 240 ALT/SIM |
| 10. CometFlash® ALT/SIM | 32. SingleFlash 60 STDY RT | 55. ActionFlash™ L/R SYNC |
| 11. DoubleFlash 75 L/R SYNC | 33. SingleFlash 60 STDY BOTH | 56. ActionFlash™ L/R ASYNC |
| 12. DoubleFlash 75 L/R ASYNC | 34. SingleFlash 90 L/R SYNC | 57. ActionFlash™ IN/OUT |
| 13. DoubleFlash 75 IN/OUT | 35. SingleFlash 90 L/R ASYNC | 58. ActionFlash™ SIM |
| 14. DoubleFlash 75 SIM | 36. SingleFlash 90 IN/OUT | 59. PingPong™ L/R SYNC |
| 15. DoubleFlash 75 ALT/SIM | 37. SingleFlash 90 SIM | 60. PingPong™ L/R ASYNC |
| 16. SingleFlash 75 L/R SYNC | 38. SingleFlash 90 ALT/SIM | 61. PingPong™ IN/OUT |
| 17. SingleFlash 75 L/R ASYNC | 39. SingleFlash 90 STDY LEFT | 62. PingPong™ SIM |
| 18. SingleFlash 75 IN / OUT | 40. SingleFlash 90 STDY RT | 63. ModuFlash™ L/R SYNC |
| 19. SingleFlash 75 SIM | 41. SingleFlash 90 STDY BOTH | 64. ModuFlash™ L/R ASYNC |
| 20. SingleFlash 75 ALT/SIM | 42. SingleFlash 120 L/R SYNC | 65. ModuFlash™ IN/OUT |
| 21. LongBurst™ L/R SYNC | 43. SingleFlash 120 L/R ASYNC | 66. ModuFlash™ SIM |
| 22. LongBurst™ L/R ASYNC | 44. SingleFlash 120 IN/OUT | 67. ActionScan™ |
| | 45. SingleFlash 120 SIM | |

L/R SYNC = LEFT / RIGHT SYNCHRONOUS

STDY LEFT = STEADY LEFT

L/R ASYNC = LEFT / RIGHT ASYNCHRONOUS

STDY RT = STEADY RIGHT

SIM = SIMULTANEOUS

STDY BOTH = STEADY BOTH

IN/OUT = IN / OUT

ALT/SIM = ALTERNATING SIMULTANEOUS

QTY	ITEM	PART NUMBER	DESCRIPTION
*		01-0690893-00	JUNIOR EXECUTIVE GSE
1	1	11-36F309-015	BASE, EXTRUDED MACHINED 15.72" JUNIOR EXECUTIVE MINI
1	2	21-11245004-1	GROMMET, SPECIAL TO BE MOLDED 1.562"
1	3	07-26E120-000	BRACKET, BULKHEAD LENS MOUNT JUNIOR EXECUTIVE
2	4	07-26J383-000	BRACKET, I/O JUNIOR EXECUTIVE
1	5	02-016H602-01	ASSY, I/O BOARD MINI SOLO 12/24V ENHANCED CIGAR PLUG
1	7	38-0123557-00	VENT MEMBRANE, .50 DIA
1	8	26-0215001-06	TY WRAP, 6" BLACK
1	9	39-1M17672-08	HOUSING, PLUG 8 POS 18 AWG SL-156 W/ LOCKING RAMP
2	10	07-247187-000	BRACKET, END CLAMP NO ALLEY JUNIOR EXECUTIVE
10	11	14-062216-081	SCREW, 6-32 X 1/2 PPHMS SEMS W/IT LOCK WASHER 410 SS
2	12	01-026F608-10	ASSY, CORNER L-FRONT/R-REAR AMB 12LED SINGLE ROW JUNIOR EX.
2	13	01-026F609-10	ASSY, CORNER L-REAR/R-FRONT AMB 12LED SINGLE ROW JUNIOR EX.
4	14	07-226275-000	BRACKET, CORNER CLAMP JUNIOR EXECUTIVE
4	15	07-247304-000	BRACKET, HALF FILLER JUNIOR EXECUTIVE
4	16	01-0247106-10	SUB ASSY, SHORT DIRECTIONAL AMB JUNIOR EX. SINGLE COLOR
2	17	07-223841-000	BRACKET, FILLER JUNIOR EXECUTIVE LTBAR

1	18	46-0787707-00	ASSY, HARNESS J1 JUNIOR EXECUTIVE
1	19	46-0787707-01	ASSY, HARNESS J6 JUNIOR EXECUTIVE
1	20	46-0787707-02	ASSY, HARNESS J2 JUNIOR EXECUTIVE
1	21	46-0787707-03	ASSY, HARNESS J5 JUNIOR EXECUTIVE
4	22	07-26F382-000	BRACKET, SNAP-IN LT MODULE MT
A/R	23	26-0215001-03	TY WRAP, 3" BLACK
2	24	02-036E774232	SUB ASSY, LENS CUT CLEAR HAZE GREY JR EXECUTIVE SERIES
2	25	38-046E119-00	SEAL, LENS DIVIDER JUNIOR EXECUTIVE
1	26	38-046E118-00	DIVIDER, LENS JUNIOR EXECUTIVE
4	27	14-104286-16J	SCREW, 10-24 X 1.25" WAX DIP SHOULDER PHTX TRI POINT SS
1	28	66-0917786-00	WIPE, STENCIL ALCOHOL REFILL CE# 440-594
4	29	66-0444378-00	TAPE, VHB ENDCAP TRIM MOUNT JUNIOR EXECUTIVE LIGHTBAR
2	30	11-26F536-009	COVER, TOP EXTRUDED 7.325" JR EXECUTIVE HAZE GREY GSE
4	31	15-105C76-148	SCREW, 10 X 7/8 T-25 TORX TRUSS HD PLAST-LOC SS W/INSEAL
1	32	02-0487333-07	OPTION, LOW PROFILE MTG FOOT PERM MOUNT
1	33	10-0322935-00	LABEL, "FRONT" LIGHTBAR ASSYS
1	34	10-0523912-01	LABEL, PN/MN/SN LIBERTY II WAT GSE
1	35	10-0523922-00	LABEL, SERIAL NUMBER JUNIOR EXECUTIVE

REFER TO PARTS DRAWING ON NEXT PAGE

