



WHELEN AEROSPACE TECHNOLOGIES

Phone: 1-772-276-6615

gse@flywat.com

51 Winthrop Road

Chester, CT 06412

Installation Guide: Apex (30 Inch)

Model: FLAPX30

Warnings to Installers

Whelen's emergency vehicle warning devices must be properly mounted and wired in order to be effective and safe. Read and follow all of Whelen's written instructions when installing or using this device. Emergency vehicles are often operated under high speed stressful conditions which must be accounted for when installing all emergency warning devices. Controls should be placed within convenient reach of the operator so that they can operate the system without taking their eyes off the roadway. Emergency warning devices can require high electrical voltages and/or currents. Properly protect and use caution around live electrical connections. Grounding or shorting of electrical connections can cause high current arcing, which can cause personal injury and/or vehicle damage, including fire. Many electronic devices used in emergency vehicles can create or be affected by electromagnetic interference. Therefore, after installation of any electronic device it is necessary to test all electronic equipment simultaneously to insure that they operate free of interference from other components within the vehicle. Never power emergency warning equipment from the same circuit or share the same grounding circuit with radio communication equipment. All devices should be mounted in accordance with the manufacturer's instructions and securely fastened to vehicle elements of sufficient strength to withstand the forces applied to the device. Driver and/or passenger air bags (SRS) will affect the way equipment should be mounted. This device should be mounted by permanent installation and within the zones specified by the vehicle manufacturer, if any. Any device mounted in the deployment area of an air bag will damage or reduce the effectiveness of the air bag and may damage or dislodge the device. Installer must be sure that this device, its mounting hardware and electrical supply wiring does not interfere with the air bag or the SRS wiring or sensors. Mounting the unit inside the vehicle by a method other than permanent installation is not recommended as unit may become dislodged during swerving; sudden braking or collision. Failure to follow instructions can result in personal injury. Whelen assumes no liability for any loss resulting from the use of this warning device. **PROPER INSTALLATION COMBINED WITH OPERATOR TRAINING IN THE PROPER USE OF EMERGENCY WARNING DEVICES IS ESSENTIAL TO INSURE THE SAFETY OF EMERGENCY PERSONNEL AND THE PUBLIC.**

Warnings to Users

Whelen's emergency vehicle warning devices are intended to alert other operators and pedestrians to the presence and operation of emergency vehicles and personnel. However, the use of this or any other Whelen emergency warning device does not guarantee that you will have the right-of-way or that other drivers and pedestrians will properly heed an emergency warning signal. Never assume you have the right-of-way. It is your responsibility to proceed safely before entering an intersection, driving against traffic, responding at a high rate of speed, or walking on or around traffic lanes. Emergency vehicle warning devices should be tested on a daily basis to ensure that they operate properly. When in actual use, the operator must ensure that both visual and audible warnings are not blocked by vehicle components (i.e.: open trunks or compartment doors), people, vehicles, or other obstructions. It is the user's responsibility to understand and obey all laws regarding emergency warning devices. The user should be familiar with all applicable laws and regulations prior to the use of any emergency vehicle warning device. Whelen's audible warning devices are designed to project sound in a forward direction away from the vehicle occupants. However, because sustained periodic exposure to loud sounds can cause hearing loss, all audible warning devices should be installed and operated in accordance with the standards established by the National Fire Protection Association.

Safety First

This document provides all the necessary information to allow your Whelen product to be properly and safely installed. Before beginning the installation and/or operation of your new product, the installation technician and operator must read this manual completely. Important information is contained herein that could prevent serious injury or damage.

⚠ WARNING: This product can expose you to chemicals including Methylene Chloride which is known to the State of California to cause cancer, and Bisphenol A, which is known to the State of California to cause birth defects or other reproductive harm. For more information go to www.P65Warnings.ca.gov.

- **Proper installation of this product requires the installer to have a good understanding of automotive electronics, systems and procedures.**
- **Whelen Engineering requires the use of waterproof butt splices and/or connectors if that connector could be exposed to moisture.**
- **Any holes, either created or utilized by this product, should be made both air- and watertight using a sealant recommended by your vehicle manufacturer.**
- **Failure to use specified installation parts and/or hardware will void the product warranty.**
- **If mounting this product requires drilling holes, the installer MUST be sure that no vehicle components or other vital parts could be damaged by the drilling process. Check both sides of the mounting surface before drilling begins. Also de-burr the holes and remove any metal shards or remnants. Install grommets into all wire passage holes.**
- **If this manual states that this product may be mounted with suction cups, magnets, tape or Velcro®, clean the mounting surface with a 50/50 mix of isopropyl alcohol and water and dry thoroughly.**
- **Do not install this product or route any wires in the deployment area of your air bag. Equipment mounted or located in the air bag deployment area will damage or reduce the effectiveness of the air bag, or become a projectile that could cause serious personal injury or death. Refer to your vehicle owner's manual for the air bag deployment area. The User/Installer assumes full responsibility to determine proper mounting location, based on providing ultimate safety to all passengers inside the vehicle.**
- **For this product to operate at optimum efficiency, a good electrical connection to chassis ground must be made. The recommended procedure requires the product ground wire to be connected directly to the NEGATIVE (-) battery post (this does not include products that use cigar power cords).**
- **If this product uses a remote device for activation or control, make sure that this device is located in an area that allows both the vehicle and the device to be operated safely in any driving condition.**
- **Do not attempt to activate or control this device in a hazardous driving situation.**
- **This product contains either strobe light(s), halogen light(s), high-intensity LEDs or a combination of these lights. Do not stare directly into these lights. Momentary blindness and/or eye damage could result.**
- **Use only soap and water to clean the outer lens. Use of other chemicals could result in premature lens cracking (crazing) and discoloration. Lenses in this condition have significantly reduced effectiveness and should be replaced immediately. Inspect and operate this product regularly to confirm its proper operation and mounting condition. Do not use a pressure washer to clean this product.**
- **It is recommended that these instructions be stored in a safe place and referred to when performing maintenance and/or reinstallation of this product.**
- **FAILURE TO FOLLOW THESE SAFETY PRECAUTIONS AND INSTRUCTIONS COULD RESULT IN DAMAGE TO THE PRODUCT OR VEHICLE AND/OR SERIOUS INJURY TO YOU AND YOUR PASSENGERS!**

Wiring and Operation:

NOTE: There is no flasher in this light. All lights will come on in steady burn when activated. You can add a flasher to the warning lights (Inboard Middle) if desired.

WARNING! All customer supplied wires that connect to the positive terminal of the battery must be sized to supply at least 125% of the maximum operating current and **FUSED** at the battery to carry that load. **DO NOT USE CIRCUIT BREAKERS WITH THIS PRODUCT!**

WHT/BLK Ground - Connect to chassis ground

BLACK Ground - Connect to chassis ground

WHITE Outer Group - Apply +12VDC to this wire to activate the Outer Group of lights.

RED Center - Apply +12VDC to this wire to activate the Center Group of lights

ORANGE Inboard Middle (warning) - Apply +12VDC to this wire to activate the Inboard Middle lights. If you wish the Inboard Middle lights to flash you must connect this wire to a flasher (customer supplied).

YELLOW ID/Clearance Lights - Apply +12VDC to this wire to activate.

Fusing: Follow the chart to determine the fusing for the control wires on your light.

IMPORTANT! It is the responsibility of the installation technician to make sure that the installation and operation of this product will not interfere with or compromise the operation or efficiency of any vehicle equipment! Before returning the vehicle to active service, visually confirm the proper operation of this product, as well as all vehicle components/equipment.

Bar size	Fuse Size			
	Outer	Center	INBD Mid	ID/Clear
30"	5 amp	3 amp	3 amp	1 amp

All fuses and switches are customer supplied

IMPORTANT WARNING!

CAUTION! DO NOT LOOK DIRECTLY AT THESE LED'S WHILE THEY ARE ON. MOMENTARY BLINDNESS AND/OR EYE DAMAGE COULD RESULT!

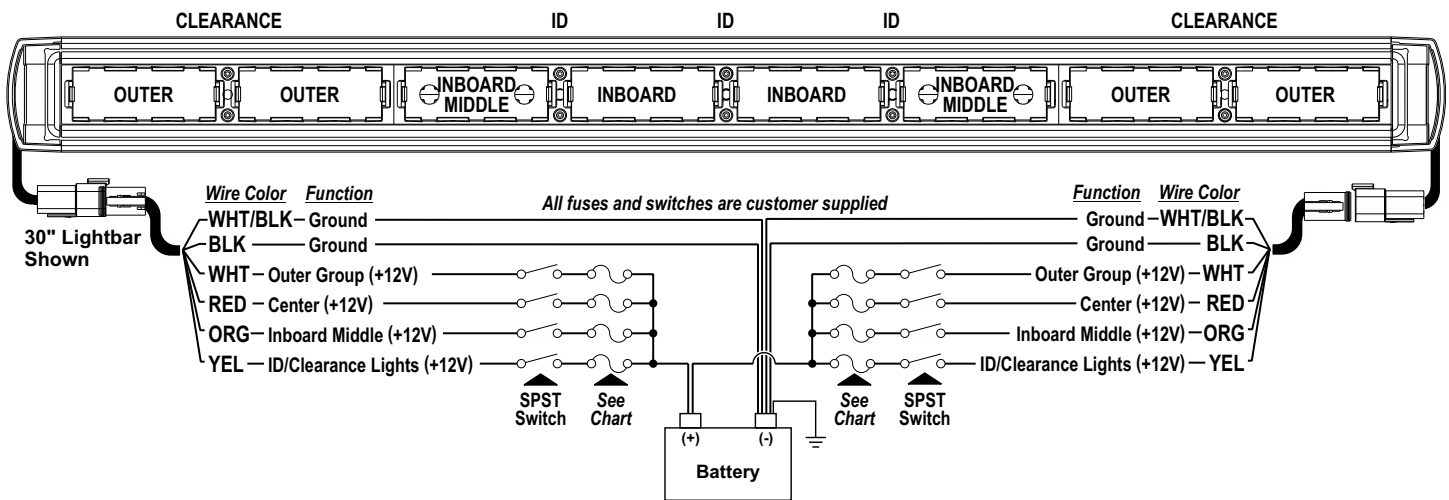

Refer to parts drawings on following pages

QTY	ITEM	PART NUMBER	DESCRIPTION
*		01-0690889-00	ASSY, 30" APEX W/ICC, WAT GSE
1	1	11-488275-301	HOUSING, MACHINED 28.00" APEX, HAZE GREY
-	2	11-488275-302	HOUSING, MACHINED 42.00" APEX, HAZE GREY
2	3	11-26H247-103	ENDCAP, MACHINED PIONEER SUMMIT, HAZE GREY
2	4	12-1418964-00	CORDGRIP, 733, 230-400 GRIP STRAIGHT-THRU W/SEALING RING
2	5	46-076H493-00	ASSY, INPUT CONNECTOR, APEX
2	6	56-047804-000	THERMAL PAD, CHO-THERM HALF MODULE APEX
1	7	56-047803-000	THERMAL PAD, CHO-THERM APEX
1	8	02-016H420-30	ASSY, PCB 2 MODULE END W1/W1 W/MARKER APEX
4	9	19-147940-000	INSERT, RETAINER APEX
1	10	02-016H418-130	ASSY, PCB 2 MOD END PASS W1/W1 W/MRKR APEX
2	11	07-747939-000	PLATE, RETAINER LENS APEX
-	12	02-016H326***	ASSY, PCB 2 MOD W/MARKER APEX
1	13	02-016H364***	ASSY, PCB 4 MOD W/MRKR SUMMIT
-	14	02-016H469-30	ASSY, PCB 2 MOD END DRVR W1/W1 W/O MARKER APEX
12	15	14-040286-06D	SCREW, 4-40 X 3/8 PAN TORX HD ROLOK SS
3	16	68-1E47796-30	LENS, CLEAR OPTIC COLLIMATOR ICC APEX
2	17	11-46H248-000	HSG, HOLDER SILICONE OPTIC HALF MODULE APEX
1	18	11-488276-000	HOUSING, HOLDER SILICONE OPTIC APEX

10	19	14-040286-20D	SCREW, 4-40 X 1-1/4 PAN TORX HD ROLOK SS
8	20	68-1E6G137-30	OPTIC, CLEAR TIR SILICONE TAKE-DOWN LIBERTY II
4	21	68-1947797-32	LENS, CLEAR OPTIC DOWNWARD APEX
A/R	22	68-1947797-*0	LENS, OPTIC 30X20 FLOOD APEX
2	23	38-0147793-00	GASKET, ENDCAP VHB APEX
8	24	14-040186-16F	SCREW, 4-40 X 1" PFH ROLOK SS W/ NYSEAL
2	25	38-0123557-00	VENT MEMBRANE, .50 DIA
A/R	26	38-0518978-00	RESIN DESIGN GEL TEK ROPE 0.125 DIA #GSP-C5I-N1-0125
1	27	68-396H249-**	LENS, CLEAR NON OPTIC APEX
8	28	19-147794-003	RETAINER, LENS APEX, HAZE GREY
2	29	19-147795-003	RETAINER, LENS APEX, HAZE GREY
2	30	46-076H496-02	ASSY, CABLE EXTENSION APEX
1	31	10-0531567-**	LABEL, APEX, WAT GSE
2	32	66-0917786-00	WIPE, STENCIL ALCOHOL REFILL CE# 440-594
4	33	15-026A16-080	SCREW, 2 X 1/2" TXFH 82 DEG PLASTITE 48-2 SS 18-8
1	34	10-0323999-00	LABEL, INSTALL WITH THIS END UP
-	35	02-016H468-130	ASSY, PCB 2 MOD END PASS W1/W1 W/O MRKR APEX
2	36	26-0718956-01	SHRINK TUBING, 1.0" W/ADHESIVE CUT TO 2.5" LENGTH 4:1 BLACK
2	37	39-1H18506-P6	HOUSING, PIN 6 POS WATERPROOF BLACK
2	38	39-1H16424-6P	WEDGE, PIN 6 POS WATERPROOF DEUTSCH
OPT	39	46-076H496-00	ASSY, CABLE EXTENSION APEX 15'

APEX ASSEMBLY

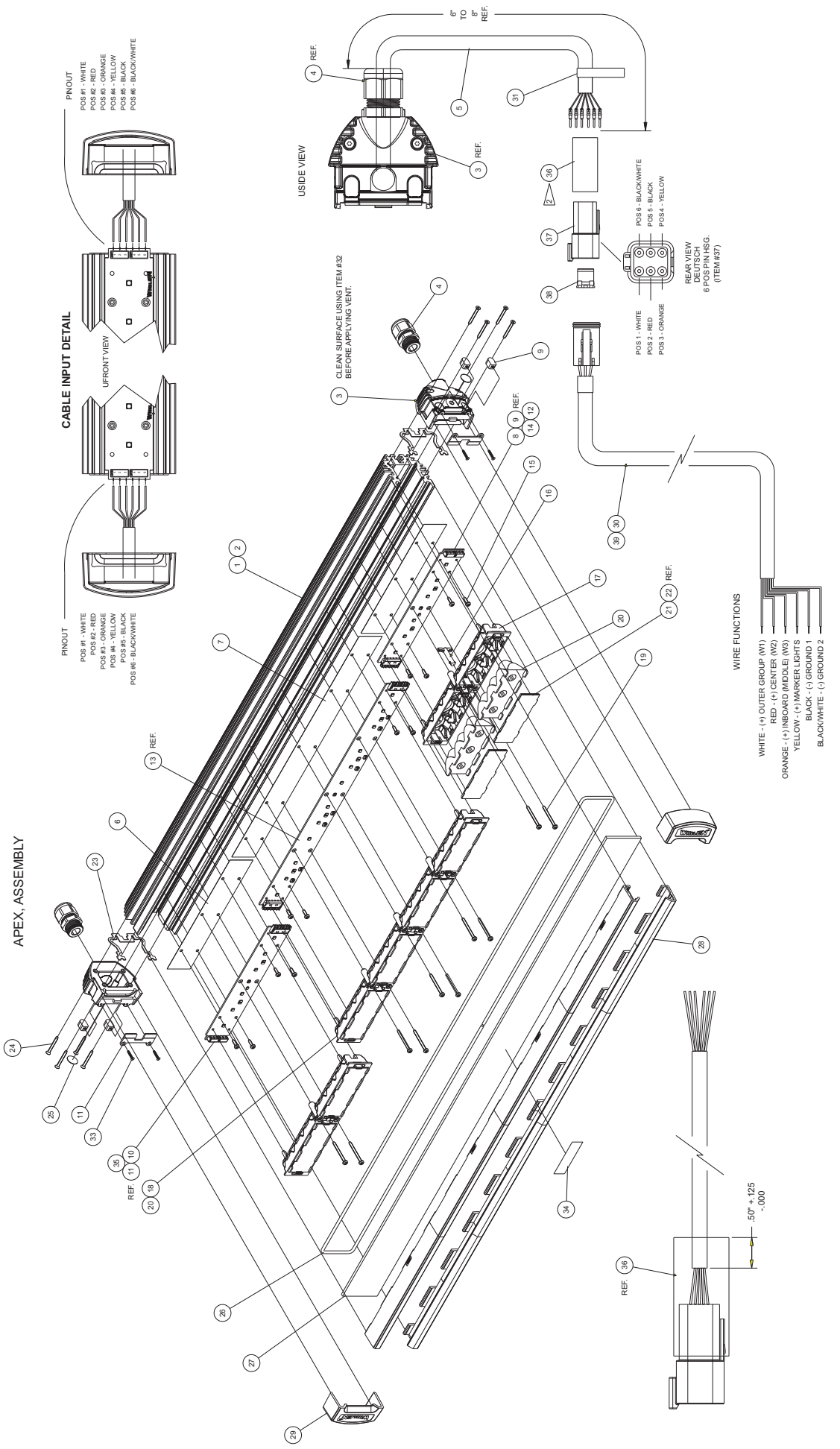

AVAILABLE OPTICS

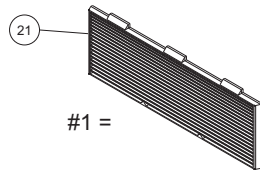

#1 =

DOWNWARD OPTIC

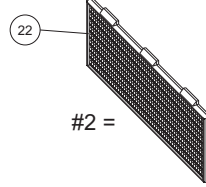

#2 =

20° X 30° CLEAR OPTIC

#3 = NO OPTIC (SPOT OPTION)

30" APEX

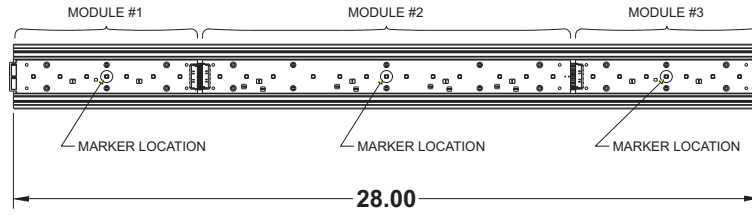

AVAILABLE OPTIC LOCATIONS

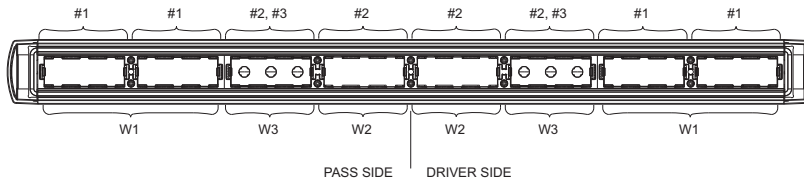

MODEL #	MODULE #1	MODULE #2	MODULE #3	W3 OPTIC #
FLAPX30	02-016H418130	02-016H3642A3	02-016H420-30	2