



WHELEN AEROSPACE TECHNOLOGIES

Phone: (860) 526-9504

Internet: www.flyWAT.com

Sales/Service e-mail: info@flyWAT.com

Installation Guide/ICA:

90792( )-series

Model(s) 90792L2, 90792R2

P/N(s): 01-0790792-L2, 01-0790792-R2

LED Position/Anti-Collision 2/1 Light Ass'y

TSO-C30c  
TYPE I, II;  
APPROVED

TSO-C96a  
CLASS II;  
APPROVED

The conditions and tests required for TSO approval of this article are minimum performance standards. Those installing this article either on or within a specific type or class of aircraft must determine that the aircraft installation conditions are within the TSO standards which include any accepted integrated non-TSO functions. TSO articles and any accepted integrated non-TSO function(s) must have separate approval for installation in an aircraft. The article may be installed only according to 14 CFR part 43 or the applicable airworthiness requirements.

**WARNING:** This product can expose you to chemicals including Methylene Chloride which is known to the State of California to cause cancer, and Bisphenol A, which is known to the State of California to cause birth defects or other reproductive harm. For more information go to www.P65Warnings.ca.gov.

**EQUIPMENT LIMITATIONS:** An approved forward lighting system consists of two lights, one located on each wingtip. The baseplate must be mounted parallel to the vertical and horizontal centerlines of the aircraft to project the patterns properly. A separate power supply unit (PSU) such as model 9079703 is required for each light assembly.

Certain types of aircraft may require additional testing.

**AIRWORTHINESS LIMITATIONS:** The Airworthiness Limitations section is FAA approved and specifies inspections and other maintenance required under §43.16 and §91.403 of the Federal Aviation Regulations, unless an alternative program has been approved.

No airworthiness limitations are associated with the installation of the light assembly.

**CONTINUED AIRWORTHINESS:** The forward position light is designed with 4 Green or 5 Red LEDs. The anti-collision light is designed with 12 LEDs. If any one bank of LEDs fails, the PSU assembly should be checked. If the PSU checks good, replace the lighthouse. If one position light LED fails, the unit must be repaired or replaced.

For the White Anti-Collision light - If a single forward-facing and/or a single aft-facing LED fails in a shorted mode, the unit is still FAR compliant.

**Note:** To reduce eye strain use an optical filter such as dark glasses or a blue covering dome during LED inspection.

Inspect the lens. Replace if there is excessive scratching, pitting, discoloration or cracking. For additional lens maintenance detail, see SAE ARP5637.

**PERIODIC INSPECTIONS:** An annual inspection shall be performed unless the OEM specifies a shorter interval.

**CLEANING:** Use only products compatible with polycarbonate to clean the outer lens. Follow the manufacturer's instructions. Use of other chemicals could result in premature lens cracking (crazing) and discoloration. Do not use a pressure washer to clean this product.

**INSTALLATION PROCEDURES:** The following information provides guidelines for the installation of a WAT LED position/anti-collision light. Please refer to the OEM manual for your aircraft for specific removal and installation instructions.

1. Choose the appropriate light assembly.
2. Using the mounting detail information provided, prepare the aircraft for means to secure the light assembly.
3. Carefully remove the screws and lens retainers. Remove the lens and gasket from the light assembly.  
**CAUTION:** Do not touch the LED with either fingers or sharp objects. This could soil and/or damage the LED and effect the optical performance of the light.
4. Using the appropriate hardware install the baseplate to the aircraft. Insure that all leads are clear of any obstructions and secured as required. Waterproof the light base to the aircraft. Apply sealant around the base where water could get in or install gasket 38-0271817-00 (sold separately). If used, install gasket with slot down.
5. Reinstall lens gasket, lens and lens retainers. Confirm proper gasket fit. Reinsert screws and tighten lightly.
6. Connect the light inputs according to the chart shown. Connections to be in accordance with FAA approved methods.
7. Check all avionics systems for interference from this installation.

D38999 / 26FB99PN		
A	AC1	WHITE ACL CATHODE AFT
B	AC2	WHITE ACL CATHODE FWD
C	NC	NO CONNECTION
D	ACV+	WHITE ACL ANODE
E	CNTL	SYNC CONTROL
F	POSV+	POSITION LIGHT ANODE
G	POS RET	POSITION LIGHT CATHODE

8. A flight check should be performed by a properly certified pilot.
9. If required, update aircraft records utilizing FAA Field Approval (Form 337) or equivalent.

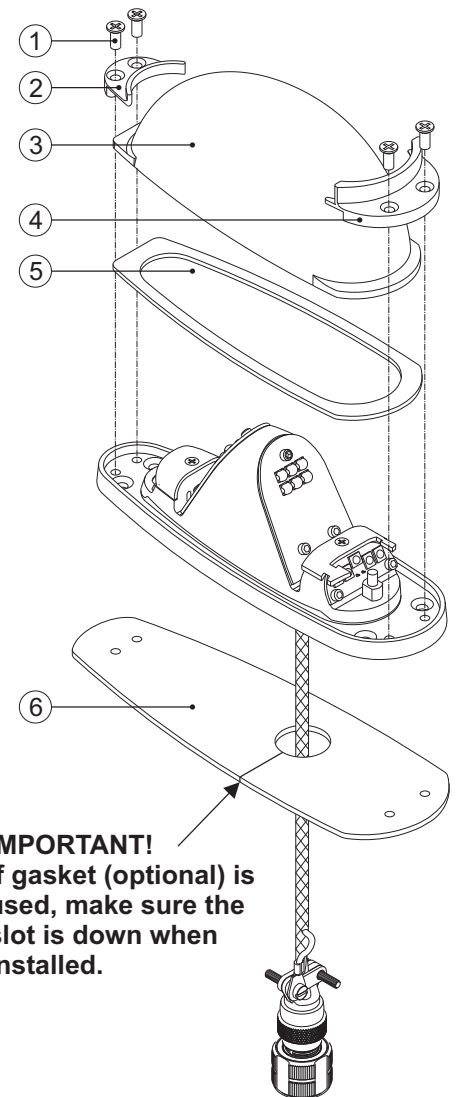
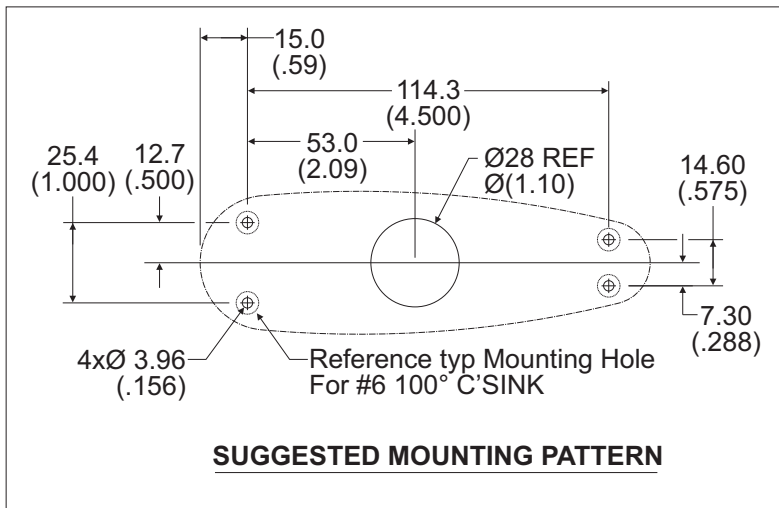
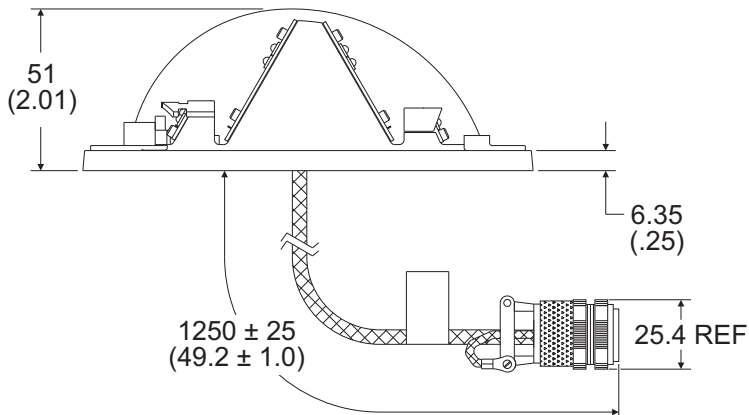
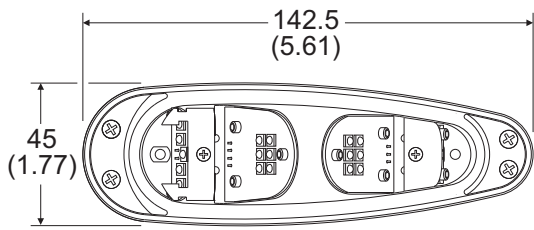

QTY	ITEM	PART NUMBER	DESCRIPTION
4	1	MS24693-3B	Screw, 4-40 x 5/16 P100FH/CSK BLK
1	2	19-151003-100	Retainer, Lens, Rear
1	3	68-3990574A30	Lens, Clear, Hardcoated
1	4	19-171471-100	Retainer, Lens, Front
1	5	38-0231219-00	Gasket, Lens
1	6	38-0271817-00	Gasket (Option, not included)