



WHELEN AEROSPACE TECHNOLOGIES

Phone: (860) 526-9504

Internet: www.flyWAT.com

Sales/Service e-mail: info@flyWAT.com

**Installation Guide/ICA:**

**Aviation model(s) OR650CGE, OR650CRE**

**P/N 01-0790701-C1, 01-0790701-C2**

**Orion 650E Wingtip Position/Anti-Collision Lighthead**

TSO-C30c  
TYPE I, II  
APPROVED

TSO-C96a  
CLASS II  
APPROVED

*The conditions and tests required for TSO approval of this article are minimum performance standards. Those installing this article either on or within a specific type or class of aircraft must determine that the aircraft installation conditions are within the TSO standards which include any accepted integrated non-TSO functions. TSO articles and any accepted integrated non-TSO function(s) must have separate approval for installation in an aircraft. The article may be installed only according to 14 CFR part 43 or the applicable airworthiness requirements.*

**WARNING:** This product can expose you to chemicals including Methylene Chloride which is known to the State of California to cause cancer, and Bisphenol A, which is known to the State of California to cause birth defects or other reproductive harm. For more information go to www.P65Warnings.ca.gov.

**SPECIFICATIONS:**

Nominal Operational Voltage: .....28VDC  
(Operational from 22-32 VDC)

**Input Current:**

Position Light (Red).....0.15 Amps  
Position Light (Green) .....0.10 Amps  
Anti-Collision Light (Avg.).....0.38 Amps  
Anti-Collision Light (Pulse).....2.0 Amps  
Flashrate .....45 ± 5 FPM

**EQUIPMENT LIMITATIONS:**

An approved forward position lighting system consists of three lights, one located on the tail and one located on each wingtip. Model OR650( )E is a wingtip position and anti-collision light. The assembly should be mounted as far outboard on the aircraft as practical. The baseplate must be mounted parallel to the vertical and horizontal centerlines of the aircraft to project the patterns properly. This assembly must be mounted behind a clear lens.

Certain types of installations may require additional testing.

**AIRWORTHINESS LIMITATIONS:**

The Airworthiness Limitations section is FAA approved and specifies inspections and other maintenance required under §43.16 and §91.403 of the Federal Aviation Regulations, unless an alternative program has been approved.

No airworthiness limitations are associated with the installation of the LED position/anti-collision light.

**CONTINUED AIRWORTHINESS:**

The forward position light is designed with green or red LEDs. The anti-collision light is designed with 24 white LEDs. If any one LED fails, the unit must be repaired or replaced.

**Note:** To reduce eye strain, use an optical filter such as dark glasses or a blue covering dome during LED inspection.

**PERIODIC INSPECTIONS:**

An annual inspection shall be performed unless the OEM specifies a shorter interval.

**INSTALLATION PROCEDURES:**

The following information is to assist you in installing a WAT light system.

1. Choose the appropriate light assembly.
2. Using the mounting detail information provided, prepare the aircraft for means to secure the light assembly.
3. Carefully remove the #4 phillips head screw (qty. 4). Remove the light assembly from the baseplate. **CAUTION! Do not touch the LED with either fingers or sharp objects. This could soil and/or damage the lens and affect the optical performance of the LEDs.**
4. Using the appropriate hardware install the baseplate to the aircraft.
5. Route the wires through the opening in the baseplate. Connect the light inputs according to the chart shown. Connect the power lead to an appropriately sized breaker. Connections to be according to FAA approved methods.  
Note: SYNC is a low-power, bi-directional control signal. Connecting to the synchronize signal of any WAT LED anti-collision assembly to another WAT anti-collision assembly will cause the lights to flash at the same time. If Synchronization is not necessary, the connection may be left open.
6. Re-install the light assembly on to the baseplate and insure that all leads are clear of any obstructions and secured as required.
7. Check all avionics systems for interference from this installation.
8. A flight check should be performed by a properly certified pilot.
9. If required, update aircraft records utilizing FAA Field Approval (Form 337) or equivalent.

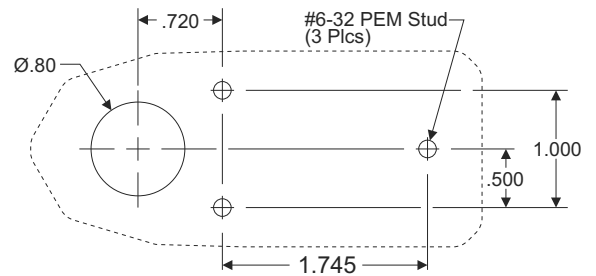

SUGGESTED MOUNTING DETAIL

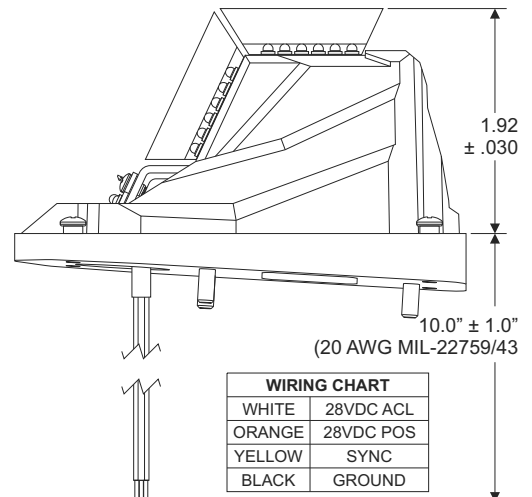
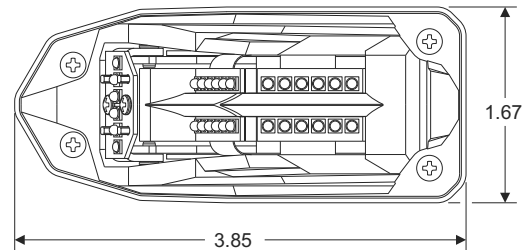

WIRING CHART	
WHITE	28VDC ACL
ORANGE	28VDC POS
YELLOW	SYNC
BLACK	GROUND

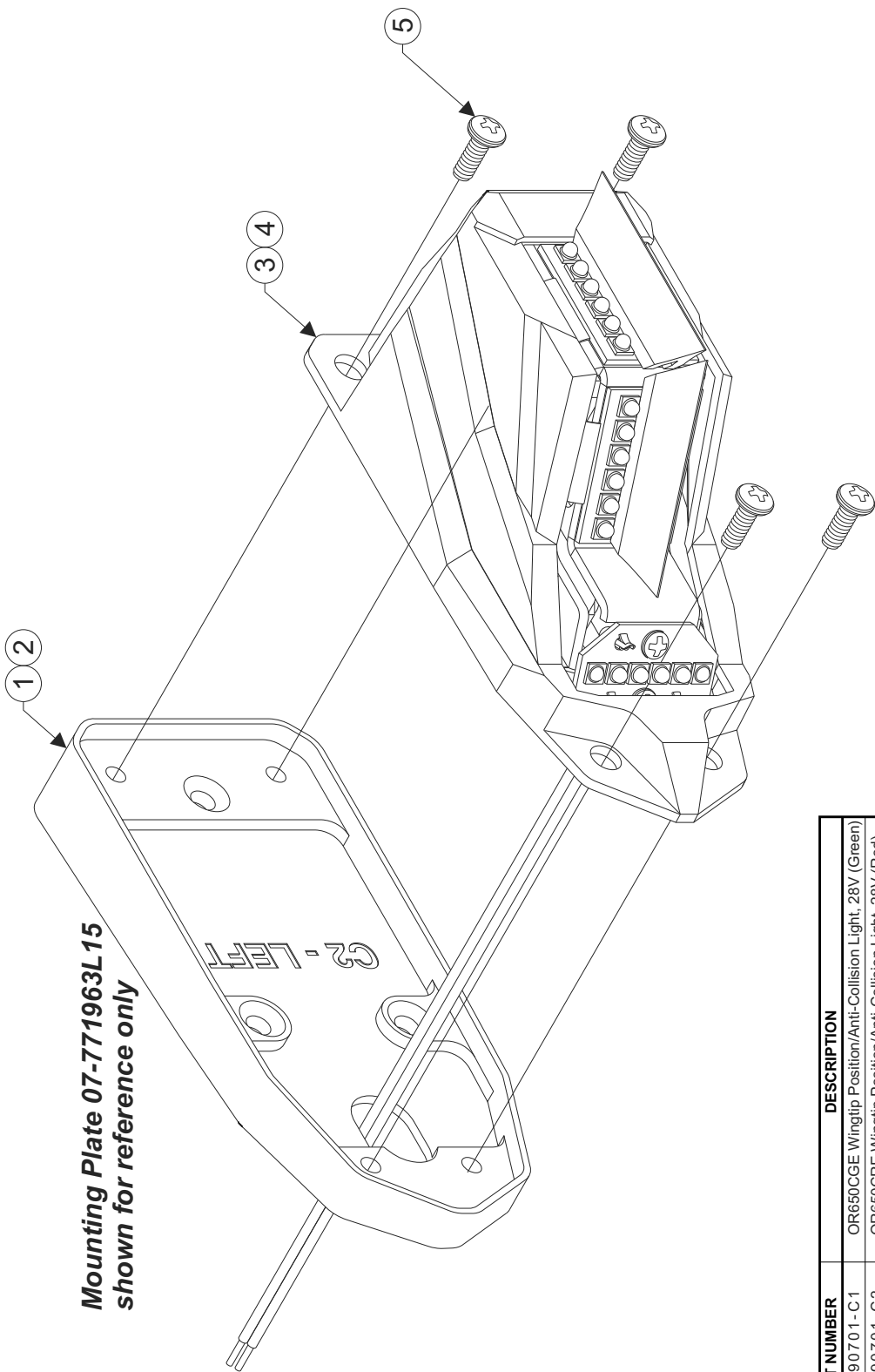

**Mounting Plate 07-771963L15  
shown for reference only**

QTY	QTY ITEM	PART NUMBER	DESCRIPTION
*		01-0790701-C1	OR650CGE Wingtip Position/Anti-Collision Light, 28V (Green)
*		01-0790701-C2	OR650CRE Wingtip Position/Anti-Collision Light, 28V (Red)
-	1	07-771963R15	Mounting Plate, Right
1	-	07-771963L15	Mounting Plate, Left
-	1		Sub-Assy, Model OR650CGE (28 VDC, GRN)
1	-		Sub-Assy, Model OR650CRE (28 VDC, RED)
4	4	14-0050505-14	Screw, #4-40 x 5/16, PPHMS (MS51957-14)