



WHELEN AEROSPACE TECHNOLOGIES

Phone: (860) 526-9504

Internet: www.flyWAT.com

Sales/Service e-mail: info@flyWAT.com

Installation Guide/ICA:

71379()-series

Models 71379L0, R0

P/N: 01-0271379-L0, -R0

LED Forward Position Light Assembly

TSO-C30c
TYPE I, II
APPROVED

The conditions and tests required for TSO approval of this article are minimum performance standards. Those installing this article either on or within a specific type or class of aircraft must determine that the aircraft installation conditions are within the TSO standards which include any accepted integrated non-TSO functions. TSO articles and any accepted integrated non-TSO function(s) must have separate approval for installation in an aircraft. The article may be installed only according to 14 CFR part 43 or the applicable airworthiness requirements.

WARNING: This product can expose you to chemicals including Methylene Chloride which is known to the State of California to cause cancer, and Bisphenol A, which is known to the State of California to cause birth defects or other reproductive harm. For more information go to www.P65Warnings.ca.gov.

OPERATING INSTRUCTIONS:

Nominal Operational Voltage: 28 VDC
(28 Volt Operation from 24-32 VDC)

Input Current: 0.25 Amps

EQUIPMENT LIMITATIONS: An approved forward position lighting system consists of two lights, one located on each wingtip. The baseplate must be mounted parallel to the vertical and horizontal centerlines of the aircraft to project the patterns properly.

Certain types of installations may require additional testing.

AIRWORTHINESS LIMITATIONS: The Airworthiness Limitations section is FAA approved and specifies inspections and other maintenance required under §43.16 and §91.403 of the Federal Aviation Regulations, unless an alternative program has been approved.

No airworthiness limitations are associated with the installation of the LED forward position light.

CONTINUED AIRWORTHINESS: The 71379 series LED wingtip position light assembly is designed with 3 Green or 4 Red LED's. Should any one LED fail, the unit must be repaired or replaced. **Note:** To reduce eye strain use an optical filter such as dark glasses or a blue covering dome during LED inspection. Inspect the lens. Replace if there is excessive scratching, discoloration or cracking. For additional lens maintenance detail, see SAE ARP5637.

PERIODIC INSPECTIONS: An annual inspection shall be performed unless the OEM specifies a shorter interval.

INSTALLATION PROCEDURES: The following information is to assist in the installation of a WAT LED Forward Position Light System.

1. Choose the appropriate 71379() light assembly.
2. Using the mounting detail information provided, prepare the aircraft for means to secure the LED light assembly.
3. Connect the position light inputs according to the chart shown. Connect the power lead to an appropriate sized breaker. Connections to be in accordance with FAA approved methods.
4. Remove the lens retainer and lens from the assembly **CAUTION!** Do not touch the LED with either fingers or sharp objects. This could soil and/or damage the LED and effect the optical performance of the assembly.

5. Using appropriate hardware, install light assembly and insure that all leads are clear of any obstructions and secured as required. Secure light assembly using vibration resistant threaded fasteners.
6. Reinstall the lens so that the two notches are positioned under the shroud, with each notch equidistant to the centerline. Confirm proper gasket fit.
7. Install lens retainer. Re-insert #6 flat head screw and tighten firmly.
8. When necessary, waterproof the light base to aircraft. Apply single part silicone (RTV) or equivalent around any open area where water could get in.
9. Check all avionics systems for interference from the installation.
10. A flight check should be performed by a properly certified pilot.
11. If required, update aircraft records utilizing FAA Field Approval (Form 337) or equivalent.

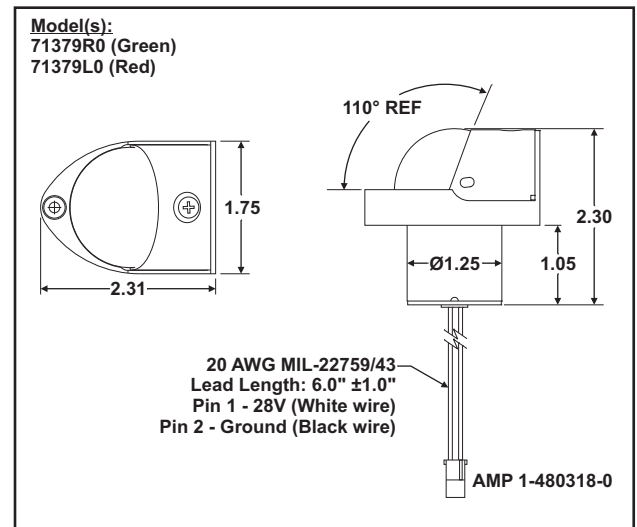

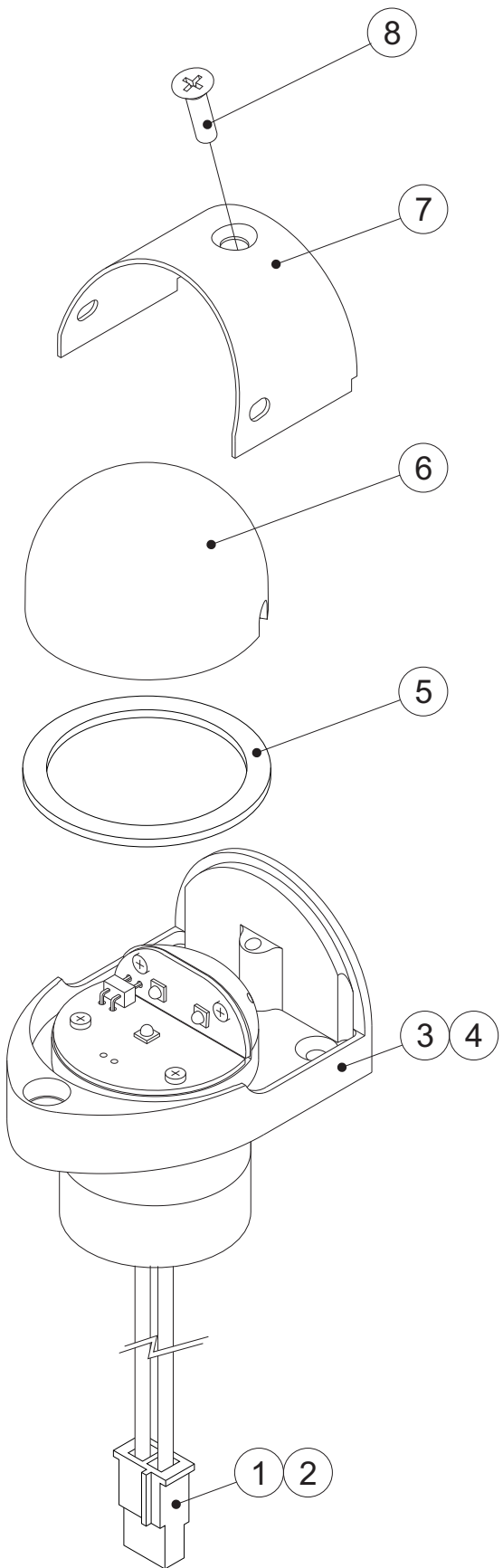

QTY	QTY	ITEM	PART NUMBER	DESCRIPTION
	*		01-0271379-R0	Assy, Forward Position Light, 28V, Black Anodized, Green
*			01-0271379-L0	Assy, Forward Position Light, 28V, Black Anodized, Red
1	1	1	39-0402023-04	Housing, 2-Position Socket
2	2	2	39-0501326-04	Socket (not shown)
-	1	3		Assy, Light Head, 28V, Black Anodized, Green
1	-	4		Assy, Light Head, 28V, Black Anodized, Red
1	1	5	38-0231440-00	Gasket, Lens
1	1	6	68-3950902A30	Lens, Hardcoat
1	1	7	19-171596-200	Retainer, Lens, Black Anodized
1	1	8	14-0050508B31	Screw, 6-32 x 5/8 PFHMS (MS51959-31B)

Mounting Hole Pattern

