



WHELEN AEROSPACE TECHNOLOGIES

Phone: (860) 526-9504

Internet: www.flyWAT.com

Sales/Service e-mail: info@flyWAT.com

Installation Guide/ICA:
Model 7155407, 7155408
P/N(s): 01-0771554-07
01-0771554-08

LED Tail Position Light Assembly

TSO-C30c
TYPE III
APPROVED

The conditions and tests required for TSO approval of this article are minimum performance standards. Those installing this article either on or within a specific type or class of aircraft must determine that the aircraft installation conditions are within the TSO standards which include any accepted integrated non-TSO functions. TSO articles and any accepted integrated non-TSO function(s) must have separate approval for installation in an aircraft. The article may be installed only according to 14 CFR part 43 or the applicable airworthiness requirements.

WARNING: This product can expose you to chemicals including Methylene Chloride which is known to the State of California to cause cancer, and Bisphenol A, which is known to the State of California to cause birth defects or other reproductive harm. For more information go to www.P65Warnings.ca.gov.

OPERATING INSTRUCTIONS:

Nominal Operational Voltage: .28 VDC
(Operation from 22-30 VDC)

Input Current: . . . . .0.12 Amps

EQUIPMENT LIMITATIONS: An approved tail position light assembly should be mounted as far aft on the aircraft as practicable on a thermally conductive surface. The baseplate must be mounted parallel to the vertical and horizontal centerlines of the aircraft to project the patterns properly.

Certain types of installations may require additional testing.

AIRWORTHINESS LIMITATIONS: The Airworthiness Limitations section is FAA approved and specifies inspections and other maintenance required under §43.16 and §91.403 of the Federal Aviation Regulations, unless an alternative program has been approved.

No airworthiness limitations are associated with the installation of the LED tail position light.

CONTINUED AIRWORTHINESS: The 7155407 and 7155408 series LED tail position light assemblies are designed with 6 LEDs. Should any one LED fail the unit must be repaired or replaced.

Note: To reduce eye strain, use an optical filter such as dark glasses or a blue covering dome during LED inspection.

Inspect the lens. Replace if there is excessive scratching, pitting, discoloration or cracking.

Inspect the lens, replace if there is excessive scratching, pitting, discoloration or cracking. For additional lens maintenance detail see SAE ARP5637.

PERIODIC INSPECTIONS: An annual inspection shall be performed unless the OEM specifies a shorter interval.

INSTALLATION PROCEDURES: The following information is to assist you in installing a WAT LED tail position light.

- 1. Using the mounting detail information provided, prepare the aircraft for means to secure the LED light assembly.
2. Connect the position light inputs according to the chart shown. Connect the power lead to an appropriate sized breaker. Connections to be in accordance with FAA approved methods.
3. Remove and discard the two screws and nuts holding the retainer to the unit. Carefully remove the lens retainer and lens from the assembly. CAUTION! Do not touch the LED surface with either fingers or sharp objects. This could soil or damage the lens and effect the optical performance of the LEDs.

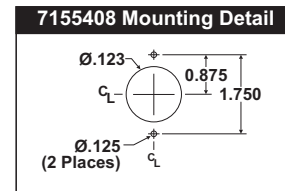
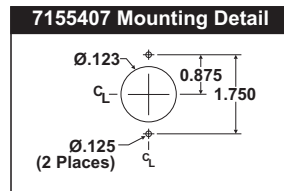
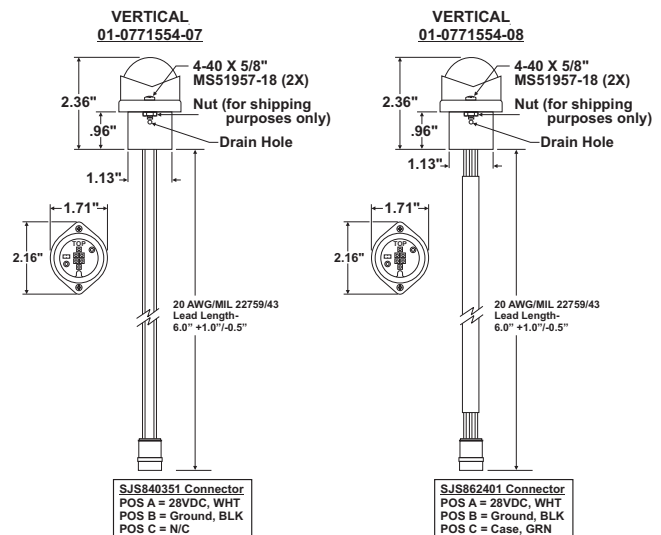

- 4. Install light assembly and insure that all leads are clear of any obstructions. Note that proper orientation is achieved with the drain hole down.
5. Reinstall the lens and confirm proper gasket fit.
6. Install the lens retainer. Using appropriate hardware secure as required. Secure light assembly using vibration resistant threaded fasteners.
7. When necessary, waterproof the light base to aircraft. Apply single part silicone (RTV) or equivalent around any open area where water could get in. Do not cover drain hole.
8. Check all avionics systems for interference from this installation.
9. A flight check should be performed by a properly certified pilot.
10. If required, update aircraft records utilizing FAA Field Approval (Form 337) or equivalent.

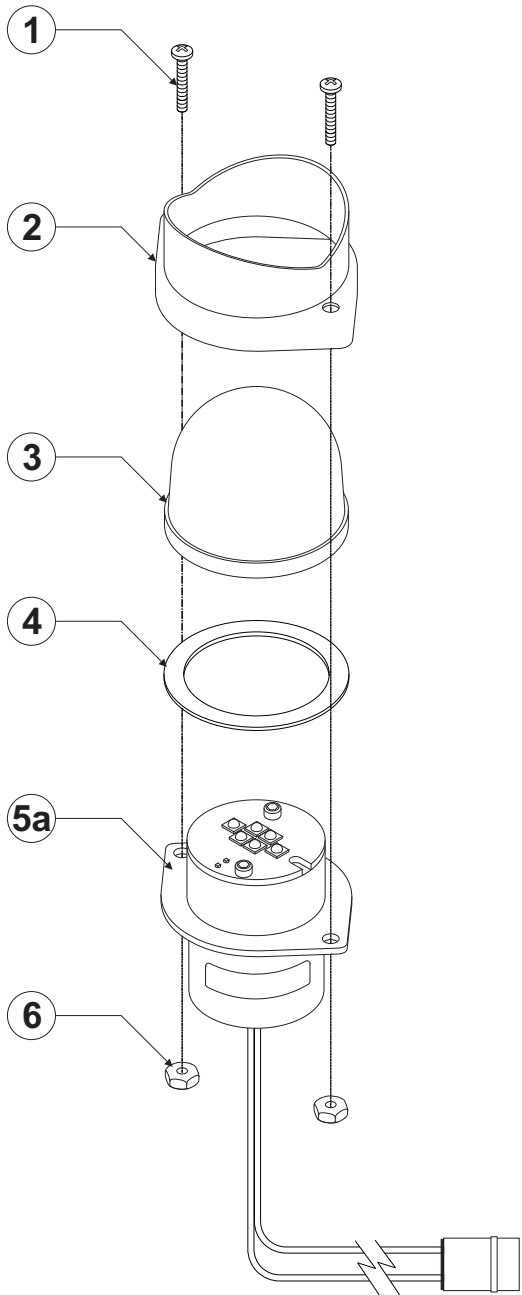

SJS840351 Connector  
 POS A = 28VDC, WHT  
 POS B = Ground, BLK  
 POS C = N/C

**Model: 7155407**

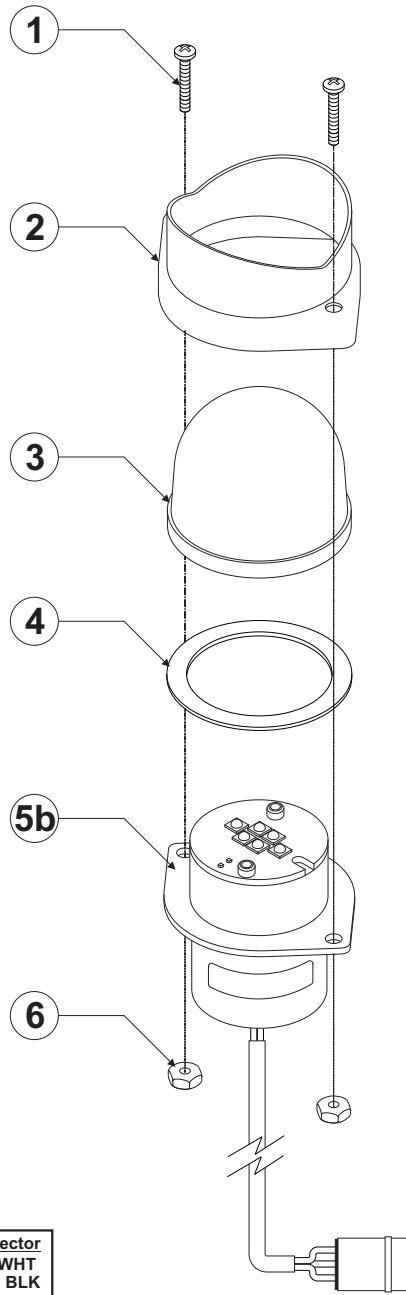

SJS862401 Connector  
 POS A = 28VDC, WHT  
 POS B = Ground, BLK  
 POS C = Case, GRN

**Model: 7155408**

QTY	QTY	ITEM	PART NUMBER	DESCRIPTION
	*		01-0771554-07	MODEL 7155407 LED TAIL POSITION LIGHT (VERT)
*			01-0771554-08	MODEL 7155408 LED TAIL POSITION LIGHT (VERT)
2	2	1	14-0050505-18	SCREW, 4-40 x 5/8 PPHMS MS51957-18
1	1	2	19-0150350-07	RETAINER MASK, VERTICAL
1	1	3	68-3970991-30	LENS, CLEAR HARDCOAT, TAIL POSITION LIGHT
1	1	4	38-0231260-00	GASKET, LENS
-	1	5a	_____	ASSY, 28V LED TAIL POSITION LIGHT (VERTICAL)
1	-	5b	_____	ASSY, 28V LED TAIL POSITION LIGHT (VERTICAL)
2	2	6	13-040130-040	NUT, 4-40 x 1/4 HEX BRASS