



WHELEN AEROSPACE TECHNOLOGIES

Phone: (860) 526-9504

Internet: www.flyWAT.com

Sales/Service e-mail: info@flyWAT.com

Installation Guide/ICA:

Model OR5001V

P/N 01-0771774V01

LED Tail Position/Anti-Collision Light Assembly

TSO-C30c
TYPE III
APPROVED

TSO-C96a
CLASS II & III
APPROVED

The conditions and tests required for TSO approval of this article are minimum performance standards. Those installing this article either on or within a specific type or class of aircraft must determine that the aircraft installation conditions are within the TSO standards which include any accepted integrated non-TSO functions. TSO articles and any accepted integrated non-TSO function(s) must have separate approval for installation in an aircraft. The article may be installed only according to 14 CFR part 43 or the applicable airworthiness requirements.

WARNING: This product can expose you to chemicals including Methylene Chloride which is known to the State of California to cause cancer, and Bisphenol A, which is known to the State of California to cause birth defects or other reproductive harm. For more information go to www.P65Warnings.ca.gov.

SPECIFICATIONS:

Nominal Operational Voltage: 12VDC
(Operational from 9-14VDC)

Input Current:

Position Lights 0.2 Amps
Anti-Collision Light (Avg.) 0.72 Amps
Anti-Collision Light (Pulse) 3.8 Amps
Flashrate 45 ± 5 FPM

EQUIPMENT LIMITATIONS: An approved position lighting system consists of three lights, one located the tail and one on each wingtip. Model OR500() is a tail position and anti-collision light. The assembly should be mounted as far aft on the aircraft as practicable on a thermally conductive surface. The baseplate must be mounted parallel to the vertical and horizontal centerlines of the aircraft to project the patterns properly.

Certain types of installations may require additional testing.

AIRWORTHINESS LIMITATIONS: The Airworthiness Limitations section is FAA approved and specifies inspections and other maintenance required under §43.16 and §91.403 of the Federal Aviation Regulations, unless an alternative program has been approved.

No airworthiness limitations are associated with the installation of the LED position/anti-collision light.

CONTINUED AIRWORTHINESS: The tail position light is designed with 4 LEDs. The anti-collision light is designed with 18 LEDs. If any one LED fails, the unit must be repaired or replaced. Inspect the lens, replace if there is excessive scratching, pitting, discoloration or cracking. For additional lens maintenance detail see SAE ARP5637. **Note:** To reduce eye strain, use an optical filter such as dark glasses or a blue covering dome during LED inspection.

PERIODIC INSPECTIONS: An annual inspection shall be performed unless the OEM specifies a shorter interval.

INSTALLATION PROCEDURES:

The following information is to assist you in installing a WAT light system.

1. Choose the appropriate light assembly.
2. Using the mounting detail information provided, prepare the aircraft for means to secure the light assembly.
3. Connect the light inputs according to the chart shown. Connect the power lead to an appropriate sized breaker. Connections to be in accordance with FAA approved methods. **Note:** SYNC is a low-power, bi-directional control signal. Connecting to the synchronize signal of any WAT LED anti-collision assembly to another WAT anti-collision assembly will cause the lights to flash at the same time. If Synchronization is not necessary, the connection may be left open.
4. Proper installed orientation is achieved with the drain hole down. **Note: The arrow on the label must point up.** Install the light assembly on to the aircraft. Insure that all leads are clear of any obstructions and secured as required.
5. When necessary, waterproof the light base to aircraft. Apply single-part Silicone (RTV) or equivalent around any open area where water could get in. Do not cover the drain hole or the back of the unit.
6. Check all avionics systems for interference from this installation.
7. A flight check should be performed by a properly certified pilot.
8. If required, update aircraft records utilizing FAA Field Approval (Form 337) or equivalent.

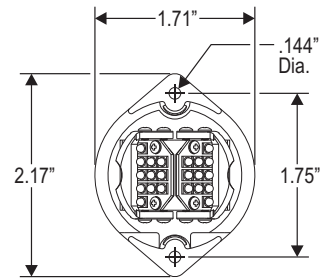
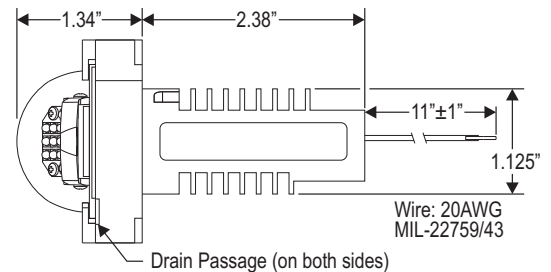

Suggested Mounting Detail

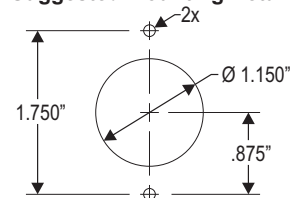

WIRING

Red+12VDC (ACL)
Orange.....+12VDC (POS)
Yellow.....SYNC
Black.....Ground

CAUTION!

DO NOT TOUCH THE LED LENS SURFACE WITH EITHER FINGERS OR SHARP OBJECTS. THIS COULD SOIL AND/OR DAMAGE THE LENS AND EFFECT THE OPTICAL PERFORMANCE OF THE LEDs

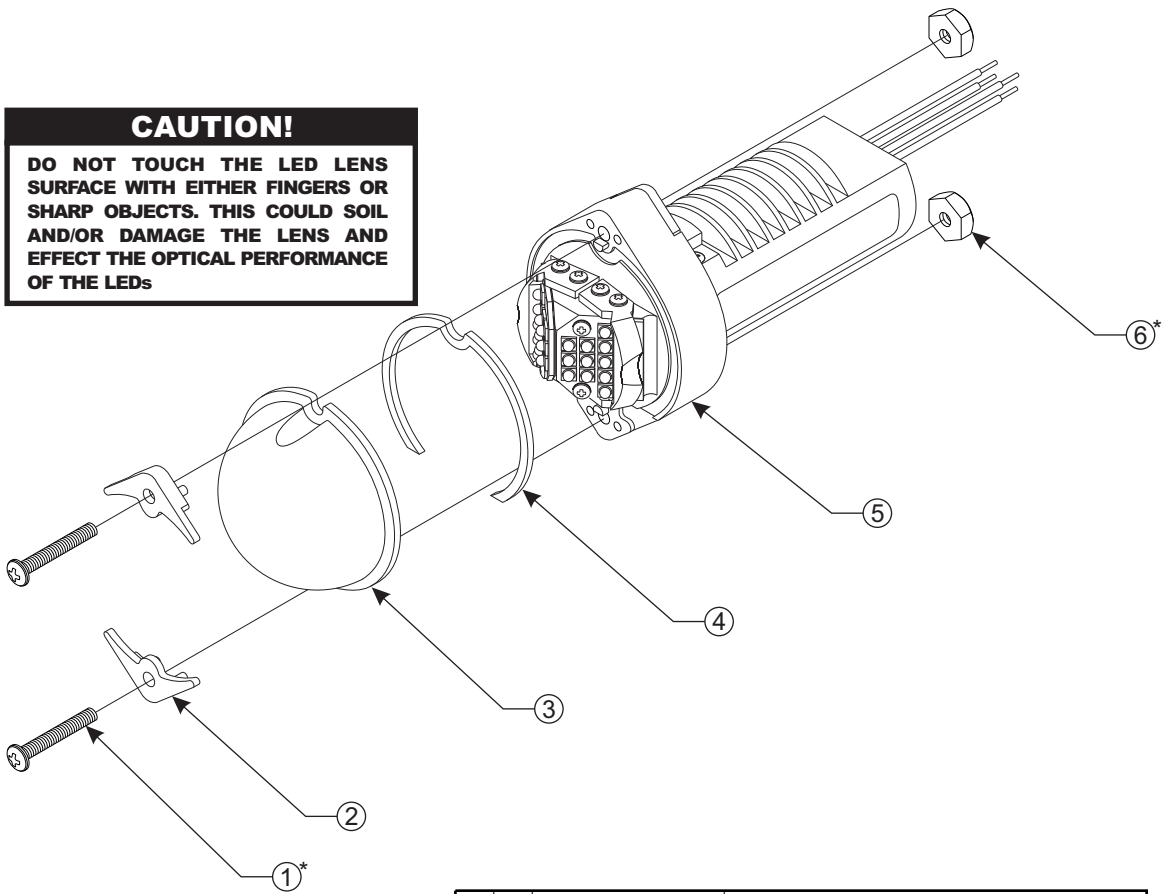

QTY	ITEM	PART NUMBER	DESCRIPTION
*		01-0771774V01	Orion-500, Model OR5001V (12VDC)
2	1*	14-040216-160	Screw, #4-40 x 1", PPHMS, SS
2	2	19-151080-100	Retainer
1	3	68-3951061A31	Lens, Model 90667
1	4	38-0131364-00	Gasket
1	5		Sub-Assy, Orion-500, Model OR5001V (12VDC)
2	6*	13-040130-040	Nut, #4-40 x 1/4, Hex Brass

* For Shipping Purposes Only