



WHELEN AEROSPACE TECHNOLOGIES

Phone: (860) 526-9504

Internet: www.flyWAT.com

Sales/Service e-mail: info@flyWAT.com

**Installation Guide/ICA:
Aviation model 9061001, 9061002
P/N 01-0790610-01, 01-0790610-02
LED Position, Anti-Collision and
Infrared Light Assembly**

TSO-C30c *TSO-C96a*
TYPE I, II & III *CLASS I*
APPROVED *APPROVED*

The conditions and tests required for TSO approval of this article are minimum performance standards. Those installing this article either on or within a specific type or class of aircraft must determine that the aircraft installation conditions are within the TSO standards which include any accepted integrated non-TSO functions. TSO articles and any accepted integrated non-TSO function(s) must have separate approval for installation in an aircraft. The article may be installed only according to 14 CFR part 43 or the applicable airworthiness requirements.

⚠ WARNING: This product can expose you to chemicals including Methylene Chloride which is known to the State of California to cause cancer, and Bisphenol A, which is known to the State of California to cause birth defects or other reproductive harm. For more information go to www.P65Warnings.ca.gov.

SPECIFICATIONS:

Nominal Operational Voltage:28 VDC
(Operation from 22-32 VDC)
Input Current:
LED Position Light0.23 Amps
LED Anti-Collision Light (Avg.)0.73 Amps
LED Anti-Collision Light (Pulse@.25 Sec.)3.9 Amps
LED Infrared Light (Avg.)0.06 Amps
LED Infrared Light (Pulse@.25 Sec.)0.3 Amps
Flashrate45 ±5 / Min.

EQUIPMENT LIMITATIONS: An approved lighting system consists of two lights, one located on each wingtip. The baseplate must be mounted parallel to the vertical and horizontal centerlines of the aircraft to project the patterns properly.

Per FAR 23.1401(d) or 25.1401(d) do not operate the anti-collision light and the infrared light at the same time.

The Infrared Light is a non-TSO function.

Certain types of installations may require additional testing.

AIRWORTHINESS LIMITATIONS: The Airworthiness Limitations section is FAA approved and specifies inspections and other maintenance required under §43.16 and §91.403 of the Federal Aviation Regulations, unless an alternative program has been approved.

No airworthiness limitations are associated with the installation of the LED anti-collision light.

CONTINUED AIRWORTHINESS: The forward position light is designed with 4 Green LEDs or 5 Red LEDs. The tail position light is designed with 2 LEDs. The infrared light is designed with 12 LEDs. The anti-collision light is designed with 36 LEDs. If any one LED fails, the unit must be repaired or replaced. Note: To reduce eye strain, use an optical filter such as dark glasses or a blue covering dome during LED inspection. Inspect the lens. Replace if there is excessive scratching, pitting, discoloration or cracking. For additional lens maintenance detail see SAE ARP5637.

Note: The anti-collision light will automatically shut-off after 9-10 flashes if a failure is detected.

PERIODIC INSPECTIONS: An annual inspection shall be performed unless the OEM specifies a shorter interval.

INSTALLATION PROCEDURES: The following information is to assist you in installing a WAT light system. The installation procedure described in the following text will be confined to a single light installation, but is identical for multiple light installations.

1. Choose the appropriate Model 90610() light assembly.
2. Using the mounting detail information provided, prepare the aircraft for means to secure the LED light assembly.
3. Connect the inputs according to the chart shown. Connect the power leads to an appropriately sized breaker. Connections to be in accordance with FAA approved methods.
4. Remove the lens retainers and carefully remove the lens. Using appropriate hardware, install the light assembly and insure that all leads are clear of any obstructions. Secure as required. Secure the light assembly using vibration resistant threaded fasteners.

5. Carefully reinstall the lens and retainers.
6. Waterproof the lightbase to aircraft. Apply single-part Silicone (RTV) or equivalent around any open area where water could get in.
7. Check all avionics systems for interference from this installation.
8. A flight check should be performed by a properly certified pilot.
9. If required, update aircraft records utilizing FAA Field Approval (Form 337) or equivalent.

Note: SYNC is a low power bi-directional control signal. Connecting to the synchronize signal of any WAT LED anti-collision assembly will cause the lights to flash at the same time. If synchronization is not necessary, the connection may be left open.

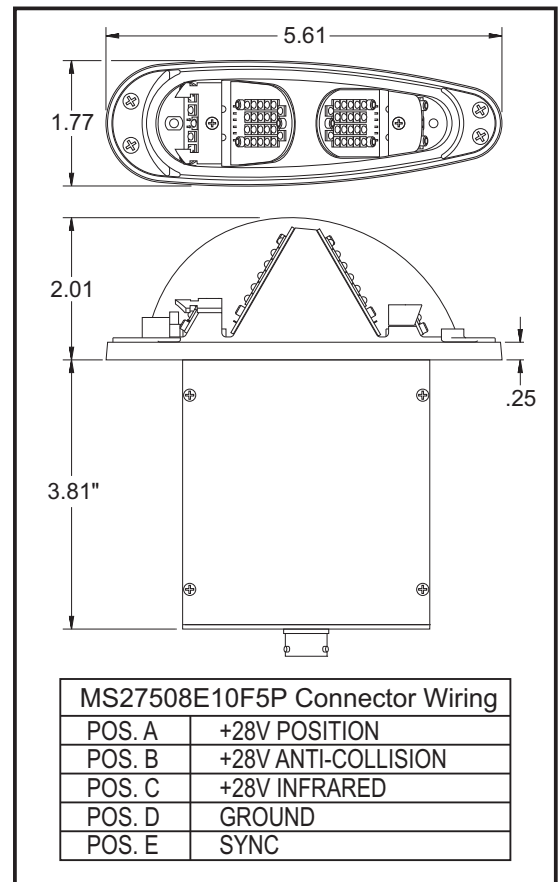

Aviation

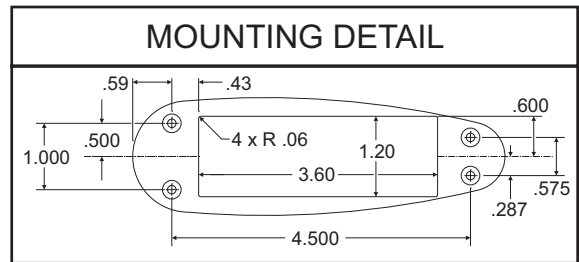
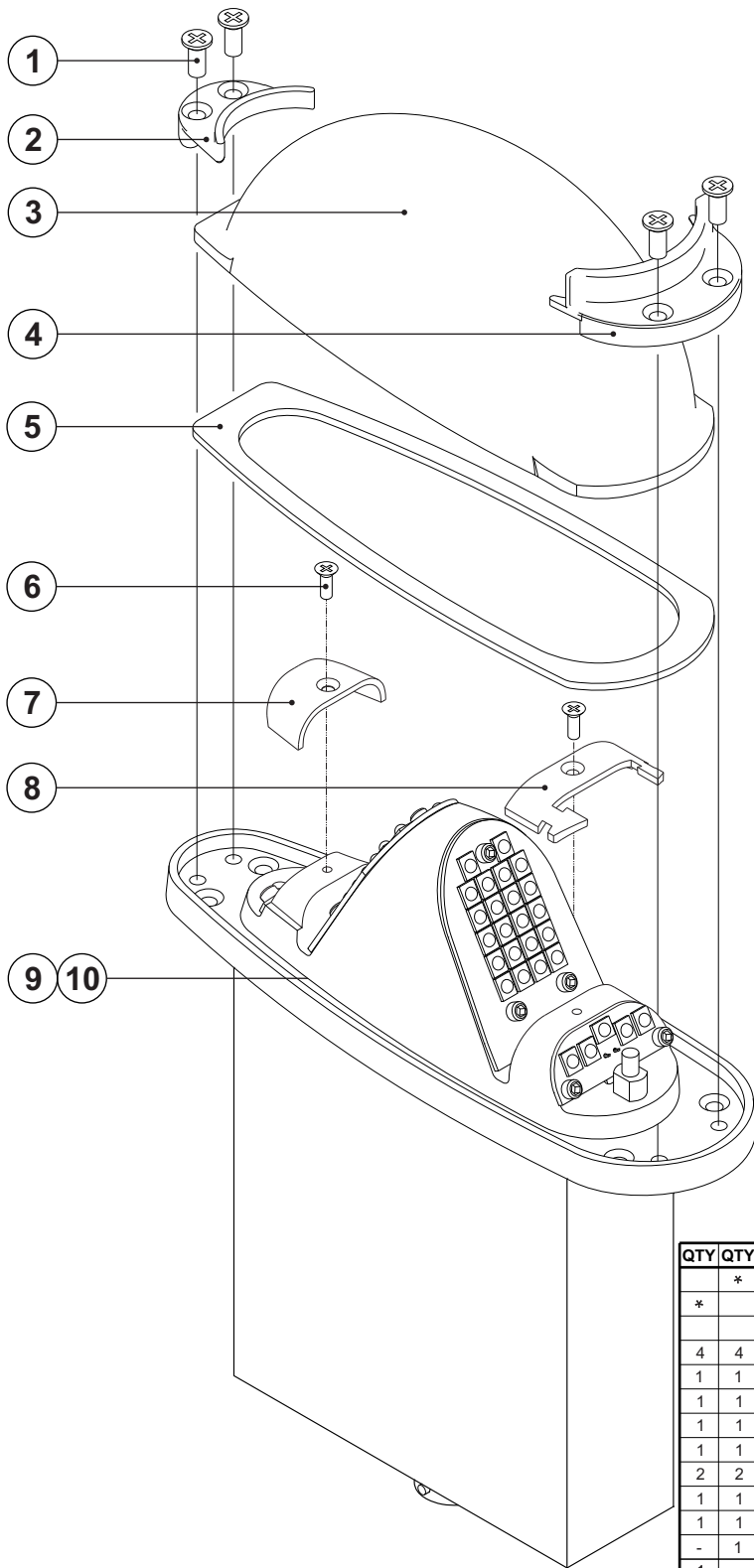

CAUTION! Do not touch the LEDs with either fingers or sharp objects. This could soil or damage the LEDs and effect the optical performance of the light.

QTY	QTY	ITEM	PART NUMBER	DESCRIPTION
	*		01-0790610-01	ASS'Y, GREEN POS. / A-C / INFRARED LIGHT
*			01-0790610-02	ASS'Y, RED POS. / A-C / INFRARED LIGHT
4	4	1	14-005508B03	SCREW, 4-40 X 5/16 PFHMS 100° C'sk, BLACK
1	1	2	19-151003-100	RETAINER, REAR
1	1	3	68-3990574A30	LENS, HARDCOATED
1	1	4	19-171471-100	RETAINER, FRONT
1	1	5	38-0231219-00	GASKET, LENS
2	2	6	14-026116-04M	SCREW, 2-56 X 1/4 P82FHMS SS w/NYLON
1	1	7	11-651008-000	SHROUD, TAIL POSITION LIGHT
1	1	8	11-651016-000	SHROUD, FORWARD POSITION LIGHT
-	1	9	—————	ASS'Y, LIGHTHEAD MODEL 9061001, GREEN
1	-	10	—————	ASS'Y, LIGHTHEAD MODEL 9061002, RED