



WHELEN AEROSPACE TECHNOLOGIES

Phone: (860) 526-9504

Internet: www.flyWAT.com

Sales/Service e-mail: info@flyWAT.com

Installation Guide/ICA:

Model 71055()-series

Model 7105519

P/N:01-0771055-19

LED Anti-Collision Light Assembly

TSO-C96a
CLASS III
APPROVED

The conditions and tests required for TSO approval of this article are minimum performance standards. Those installing this article either on or within a specific type or class of aircraft must determine that the aircraft installation conditions are within the TSO standards which include any accepted integrated non-TSO functions. TSO articles and any accepted integrated non-TSO function(s) must have separate approval for installation in an aircraft. The article may be installed only according to 14 CFR part 43 or the applicable airworthiness requirements.

WARNING: This product can expose you to chemicals including Methylene Chloride which is known to the State of California to cause cancer, and Bisphenol A, which is known to the State of California to cause birth defects or other reproductive harm. For more information go to www.P65Warnings.ca.gov.

OPERATING INSTRUCTIONS:

Nominal Operational Voltage: 28VDC
(Operation from 22V - 32V)

Input Current:

Average: 0.56 Amps
Pulse 1.5 Amps
Flashrate: 45 ±5 FPM

Model 7105519 comes with a masked lens to reduce light output in a given direction.

EQUIPMENT LIMITATIONS: An approved anti-collision light assembly should be located so that their light will not impair the crew's vision or detract from the conspicuity of the position lights. The baseplate must be mounted parallel to the vertical and horizontal centerlines of the aircraft to project the patterns properly.

Certain types of installations may require additional testing.

AIRWORTHINESS LIMITATIONS: The Airworthiness Limitations section is FAA approved and specifies inspections and other maintenance required under §43.16 and §91.403 of the Federal Aviation Regulations, unless an alternative program has been approved.

No airworthiness limitations are associated with the installation of the LED anti-collision light.

CONTINUED AIRWORTHINESS: The 7105519 LED anti-collision light assembly is designed with 6 vertical columns consisting of 3 LEDs each. If any one LED fails, the unit must be repaired or replaced. Inspect the lens, replace if there is excessive scratching, pitting, discoloration or cracking. For additional lens maintenance detail see SAE ARP5637. **NOTE:** To reduce eye strain, use an optical filter such as dark glasses or a blue covering dome during LED inspection.

PERIODIC INSPECTIONS: An annual inspection shall be performed unless the OEM specifies a shorter interval.

INSTALLATION PROCEDURES: The following information is to assist in the installation of a WAT LED Anti-collision Light System.

- Using the mounting detail information provided, prepare the aircraft for means to secure the light assembly.
- Carefully remove the #4 Phillips screw and lens retainer. Remove the lens. CAUTION! Do not touch the LEDs with either fingers or sharp objects. This could soil and/or damage the LED and effect the optical performance of the LEDs. Remove the 4 Phillips head screws securing the adapter plate to the light assembly. Remove the adapter.
- Using the appropriate hardware, install the adapter plate to the aircraft.
- Route the wires through the opening in the adapter plate. Connect the light inputs according to the chart shown. Connect the power lead to an appropriately sized breaker. Connections to be in accordance with FAA approved methods.
- Reinstall the light assembly onto the adapter plate and insure that all leads are clear of any obstructions and secured as required.
- Reinstall gasket and lens. Position the masked lens for desired light blockage. Confirm proper gasket fit. Reinstall lens retainer and screws. Tighten firmly.
- All inverted (bottom) mounted units shall require waterproofing of the base assembly to the aircraft. NOTE: Drill a 1/8" hole in the center of the lens for bottom mount units.
- Check all avionics systems for interference from this installation.
- A flight check should be performed by a properly certified pilot.
- If required, update aircraft records utilizing FAA Field Approval (Form 337) or equivalent.

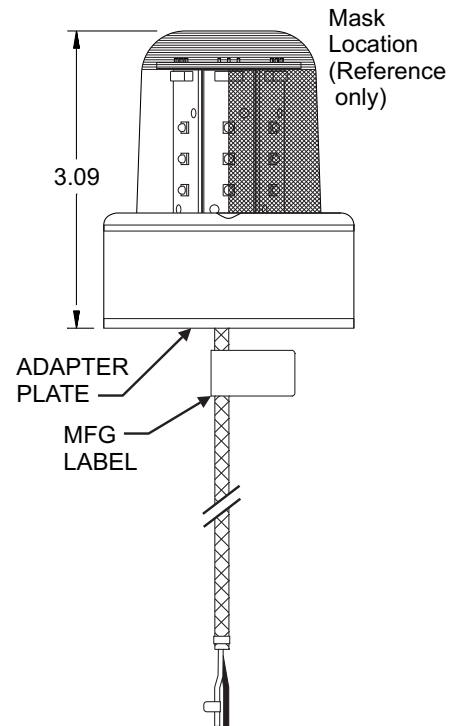
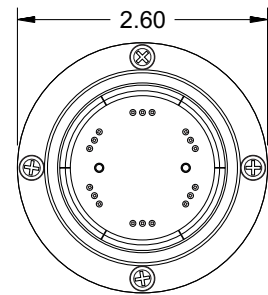

White 18 AWG - (+) 28VDC
Black 18 AWG - (-) Ground

