



WHELEN AEROSPACE TECHNOLOGIES

Phone: (860) 526-9504
 Fax: (860) 526-2009
 Internet: www.flyWAT.com
 Sales/Service e-mail: info@flyWAT.com

**Installation Guide/ICA:
 Aviation model 7145701
 P/N 01-0771457-01
 Flasher/Current Source**

TSO-C30c
 TYPES I, II & III
 APPROVED

TSO-C96a
 CLASS II
 APPROVED

The conditions and tests required for TSO approval of this article are minimum performance standards. Those installing this article either on or within a specific type or class of aircraft must determine that the aircraft installation conditions are within the TSO standards which include any accepted integrated non-TSO functions. TSO articles and any accepted integrated non-TSO function(s) must have separate approval for installation in an aircraft. The article may be installed only according to 14 CFR part 43 or the applicable airworthiness requirements.

SPECIFICATIONS:

Nominal Operational Voltage:..... 28 VDC
 (Operation from 22-32 VDC)
 Input Current (with 905690x Lighthouse):
 LED Forward Position Light..... 0.23 Amps
 LED Anti-Collision Light (Pulse@.25 Sec.)..... 3.9 Amps
 LED Anti-Collision Light (Avg.)..... 0.73 Amps
 Flashrate..... 45 ±5 Per. Min.

EQUIPMENT LIMITATIONS: An approved Anti-Collision / Position Light System consists of at least 2 flasher/current source units, each connected to a LED anti-collision/position light lighthouse.

Certain types of installations may require additional testing.

AIRWORTHINESS LIMITATIONS: The Airworthiness Limitations section is FAA approved and specifies inspections and other maintenance required under §43.16 and §91.403 of the Federal Aviation Regulations, unless an alternative program has been approved.

No airworthiness limitations are associated with the installation of the flasher/current source.

CONTINUED AIRWORTHINESS: If any bank of LEDs fail, the lighthouse module should be checked. If the module checks good, replace the flasher.

Note: An anti-collision light will automatically shut-off after 9-10 flashes if a failure is detected.

INSTALLATION PROCEDURES:

1. Consider areas or locations designated by the aircraft manufacturer. Check that breakers are properly rated.
2. Using appropriate hardware, install the flasher assembly.
3. Connect the inputs according to the chart shown. Connections to be in accordance with FAA approved methods.
4. Insure that all leads are clear of any obstructions and secure as required.
5. Check all avionic systems for interference from the installation
6. A flight check should be performed by a certified pilot
7. If required, update aircraft records utilizing FAA Field Approval (Form 337) or equivalent.

Note: SYNC is a low powered, bi-directional control signal. Connecting to the synchronize signal of any WAT LED anti collision assembly will cause the lights to flash at the same time. If synchronization is not necessary, the connection may be left open.

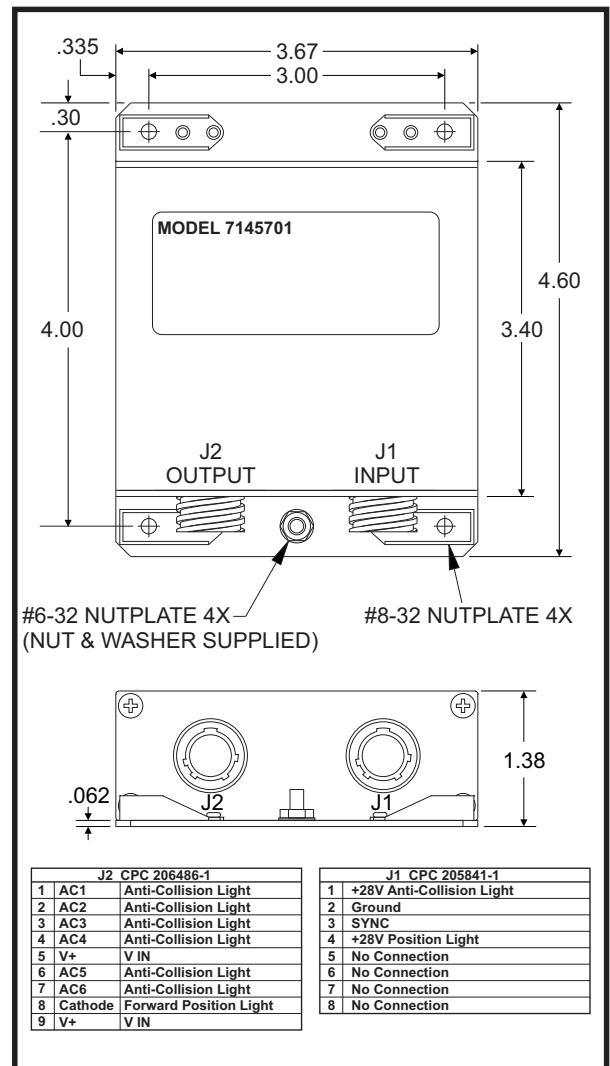

Aviation