



WHELEN AEROSPACE TECHNOLOGIES

Phone: (860) 526-9504
 Fax: (860) 526-2009
 Internet: www.flyWAT.com
 Sales/Service e-mail: info@flyWAT.com

**Installation Guide/ICA:
 Aviation model 7145750
 P/N 01-0771457-50
 Flasher/Current Source**

**TSO-C30c
 TYPES I, II & III
 APPROVED**

**TSO-C96a
 CLASS II
 APPROVED**

The conditions and tests required for TSO approval of this article are minimum performance standards. Those installing this article either on or within a specific type or class of aircraft must determine that the aircraft installation conditions are within the TSO standards which include any accepted integrated non-TSO functions. TSO articles and any accepted integrated non-TSO function(s) must have separate approval for installation in an aircraft. The article may be installed only according to 14 CFR part 43 or the applicable airworthiness requirements.

SPECIFICATIONS:

- Nominal Operational Voltage:..... 28 VDC
 (Operation from 22-32 VDC)
- Input Current (with 905695x Lighthouse):

 - LED Position Light..... 0.23 Amps
 - LED Anti-Collision Light (Pulse@.25 Sec.)..... 3.9 Amps
 - LED Anti-Collision Light (Avg.)..... 0.73 Amps
 - LED I.R. Light (Pulse@.25 Sec.) 0.3 Amps
 - LED I.R. Light (Avg.) 0.06 Amps

- Flashrate..... 45 ±5 Per. Min.

EQUIPMENT LIMITATIONS: An approved Anti-Collision / Position Lighting System consists of at least 2 flasher/current source units, each connected to a LED anti-collision, position and infrared light lighthouse.

Note: Due to circuitry relationship, the anti-collision and I.R. lights cannot both be on at the same time.

The Infrared Light is a non-TSO function.

Certain types of installations may require additional testing.

AIRWORTHINESS LIMITATIONS: The Airworthiness Limitations section is FAA approved and specifies inspections and other maintenance required under §43.16 and §91.403 of the Federal Aviation Regulations, unless an alternative program has been approved.

No airworthiness limitations are associated with the installation of the flasher/current source.

CONTINUED AIRWORTHINESS: If any bank of LEDs fail, the lighthouse module should be checked. If the module checks good, replace the flasher.

Note: An anti-collision light will automatically shut-off after 9-10 flashes if a failure is detected.

INSTALLATION PROCEDURES:

1. Consider areas or locations designated by the aircraft manufacturer. Check that breakers are properly rated.
2. Attach the flasher using the (4) 0.156 dia. mounting holes.
3. Connect the inputs according to the chart shown. Connections to be in accordance with FAA approved methods.
4. Check all avionic systems for interference from the installation.
5. A flight check should be performed by a certified pilot.
6. If required, update aircraft records utilizing FAA Field Approval (Form 337) or equivalent.

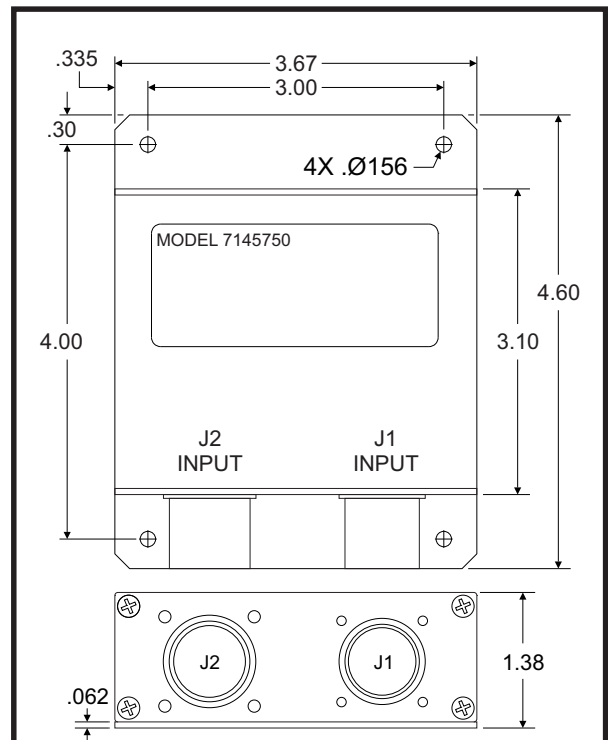

Model:7145750

J2 MS27508E12F98S		J1 MS27508E10F5P	
A	AC1 Anti-Collision Light	A	+28V Anti-Collision Light
B	AC2 Anti-Collision Light	B	Ground
C	AC3 Anti-Collision Light	C	SYNC
D	AC4 Anti-Collision Light	D	+28V Position Light
E	V+ V IN	E	+28V IR Light
F	AC5 Anti-Collision Light		
G	AC6 Anti-Collision Light		
H	Cathode FWD & AFT Position Lights		
J	Cathode IR Light		
K	V+ V IN		

Aviation