



WHELEN AEROSPACE TECHNOLOGIES

Phone: (860) 526-9504

Fax: (860) 526-2009

Internet: www.flyWAT.com

Sales/Service e-mail: info@flyWAT.com

**Installation Guide/ICA:
Aviation model 9056901, 9056902
P/N 01-0790569-01, 01-0790569-02
LED Position, Anti-Collision and
Ground Recognition Light Assembly**

**TSO-C30c
TYPES I, II & III
APPROVED**

**TSO-C96a
CLASS II
APPROVED**

The conditions and tests required for TSO approval of this article are minimum performance standards. Those installing this article either on or within a specific type or class of aircraft must determine that the aircraft installation conditions are within the TSO standards which include any accepted integrated non-TSO functions. TSO articles and any accepted integrated non-TSO function(s) must have separate approval for installation in an aircraft. The article may be installed only according to 14 CFR part 43 or the applicable airworthiness requirements.

EQUIPMENT LIMITATIONS: An approved lighting system consists of two lights, one located on each wingtip. The baseplate must be mounted parallel to the vertical and horizontal centerlines of the aircraft to project the patterns properly. A separate flasher assembly, such as model 7145700, is required for each light assembly.

The Ground Recognition Light is a non-TSO function.

Certain types of installations may require additional testing.

AIRWORTHINESS LIMITATIONS: The Airworthiness Limitations section is FAA approved and specifies inspections and other maintenance required under §43.16 and §91.403 of the Federal Aviation Regulations, unless an alternative program has been approved.

No airworthiness limitations are associated with the installation of the LED position/anti-collision/ground recognition light.

CONTINUED AIRWORTHINESS: The forward position light is designed with 4 Green LEDs or 5 Red LEDs. The tail position light is designed with 2 LEDs. The ground recognition light is designed with 8 LEDs. The anti-collision light is designed with 36 LEDs.

If any one bank of LEDs fails, the flasher module should be checked. If module checks good, replace the lighthouse. If any one LED fails, the unit must be repaired or replaced. Inspect the lens. Replace if there is excessive scratching, pitting, discoloration or cracking. For additional lens maintenance detail, see SAE ARP5637.

Note: The anti-collision light will automatically shut-off after 9-10 flashes if a failure is detected.

PERIODIC INSPECTIONS: An annual inspection shall be performed unless the OEM specifies a shorter interval.

INSTALLATION PROCEDURES: The following information is to assist you in installing a WAT light system. The installation procedure described in the following text will be confined to a single light installation, but is identical for multiple light installations.

1. Choose the appropriate Model 90569() replacement light assembly.
2. Using the mounting detail information on page 2, prepare the aircraft for means to secure the LED light assembly. Remove any existing mounting adapters.
3. Connect the light inputs according to the chart shown. Connections to be in accordance with FAA approved methods.

4. Remove the lens retainers and carefully remove the lens. Using appropriate hardware, install the light assembly and insure that all leads are clear of any obstructions. Ty-rap as required. Secure the light assembly using vibration resistant threaded fasteners.
5. Carefully reinstall the lens and retainers.
6. Waterproof the lightbase to aircraft. Apply single-part Silicone (RTV) or equivalent around any open area where water could get in.
7. Check all avionics systems for interference from this installation.
8. A flight check should be performed by a properly certified pilot.
9. If required, update aircraft records utilizing FAA Field Approval (Form 337) or equivalent.

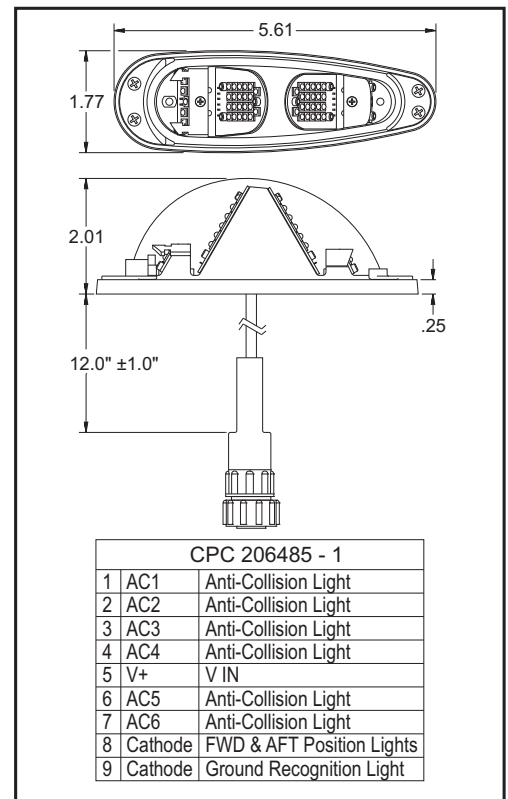

Aviation

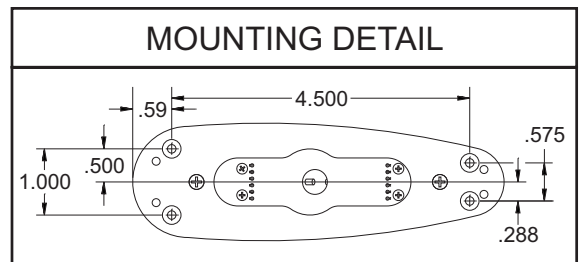
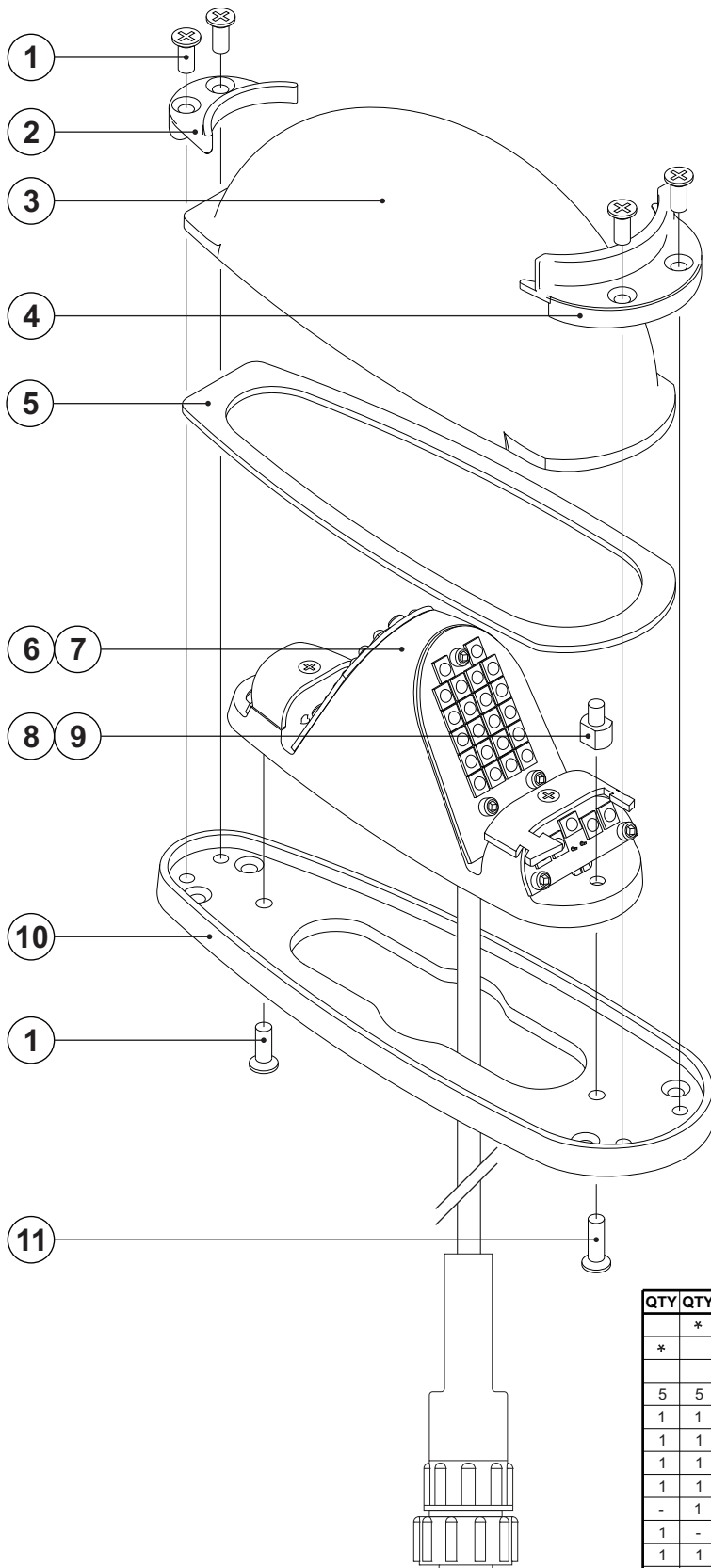

CAUTION! Do not touch the LEDs with either fingers or sharp objects, as this could soil or damage the LEDs and effect the optical performance of the light.

QTY	QTY	ITEM	PART NUMBER	DESCRIPTION
	*		01-0790569-01	ASS'Y, GREEN POS. / A-C / GND. REC. LIGHT
	*		01-0790569-02	ASS'Y, RED POS. / A-C / GND. REC. LIGHT
5	5	1	14-0050581-03	SCREW, 4-40 X 5/16 PFHMS 100° C'sk
1	1	2	19-151003-100	RETAINER, REAR
1	1	3	68-3990574A30	LENS, HARDCOATED
1	1	4	19-171471-100	RETAINER, FRONT
1	1	5	38-0231219-00	GASKET, LENS
-	1	6		ASS'Y, LIGHTHEAD MODEL 9056901, GREEN
1	-	7		ASS'Y, LIGHTHEAD MODEL 9056902, RED
1	1	8	68-5451007-00	REFLECTOR, 90°
A/R	A/R	9	66-0715403-00	Threadlocker, 242 Loctite 50ml
1	1	10	06-171472-100	BASE PLATE
1	1	11	14-0050581-05	SCREW, 4-40 X 7/16 PFHMS 100° C'sk