



WHELEN AEROSPACE TECHNOLOGIES

Phone: (860) 526-9504

Internet: www.flyWAT.com

Sales/Service e-mail: info@flyWAT.com

Installation Guide/ICA:
Model 71410( )-series
Model(s) 7141008, 7141018
P/N:01-0771410-08, 01-0771410-18
LED Flashing Anti-Collision Light Assembly

TSO-C96a
CLASS III
APPROVED

The conditions and tests required for TSO approval of this article are minimum performance standards. Those installing this article either on or within a specific type or class of aircraft must determine that the aircraft installation conditions are within the TSO standards which include any accepted integrated non-TSO functions. TSO articles and any accepted integrated non-TSO function(s) must have separate approval for installation in an aircraft. The article may be installed only according to 14 CFR part 43 or the applicable airworthiness requirements.

WARNING: This product can expose you to chemicals including Methylene Chloride which is known to the State of California to cause cancer, and Bisphenol A, which is known to the State of California to cause birth defects or other reproductive harm. For more information go to www.P65Warnings.ca.gov.

OPERATING INSTRUCTIONS:

- Operational Voltage: . . . . . 28 VDC nominal
Average Input Current: . . . . . 0.32 Amps
Pulse Input Current: . . . . . 1.4 Amps @ .3 Seconds

The Model 71410 series LED anti-collision light assembly meets the requirements of FAR 91.205(c)(3).

EQUIPMENT LIMITATIONS: An approved anti-collision light assembly should be located so that their light will not impair the crew's vision or detract from the conspicuity of the position lights. The baseplate must be mounted parallel to the vertical and horizontal centerlines of the aircraft to project the patterns properly.

Certain types of installations may require additional testing.

AIRWORTHINESS LIMITATIONS: The Airworthiness Limitations section is FAA approved and specifies inspections and other maintenance required under §43.16 and §91.403 of the Federal Aviation Regulations, unless an alternative program has been approved.

No airworthiness limitations are associated with the installation of the LED anti-collision light.

CONTINUED AIRWORTHINESS: The 71410 series LED anti-collision light assembly is designed with 8 vertical columns consisting of 3 white LEDs each. Should any one LED or any vertical column fail, the unit must be repaired or replaced. NOTE: To reduce eye strain, use an optical filter such as dark glasses or a blue covering dome during LED inspection.

Inspect the lens, replace if there is excessive scratching, pitting, discoloration or cracking. For additional lens maintenance detail see SAE ARP5637.

PERIODIC INSPECTIONS: An annual inspection shall be performed unless the OEM specifies a shorter interval.

INSTALLATION PROCEDURES: The following information is to assist in the installation of a WAT LED anti-collision light system.

- 1. Using the "suggested mounting hole pattern" prepare the aircraft for means to secure the LED anti-collision light assembly. Remove any existing mounting adapters.
2. 28 VDC (+) and (-) ground leads equipped with an appropriate sized breaker to be supplied to the LED anti-collision light assembly system. Both leads must be connected by an approved FAA connection. Insure that the wire leads are clear of any obstructions and ty-wrap as required.
3. Install the light assembly by securing to the aircraft using appropriate approved hardware. Refer to page 2. CAUTION! Do not touch the LEDs with either fingers or sharp objects. This could soil and/or damage the LED and effect the optical performance of the LEDs.
4. All inverted (bottom) mounted units shall require waterproofing of the flasher base assembly to the aircraft.
5. Check all avionics systems for interference from this installation.
6. A flight check should be performed by a properly certified pilot.
7. If required, update aircraft records utilizing FAA Field Approval (Form 337) or equivalent.

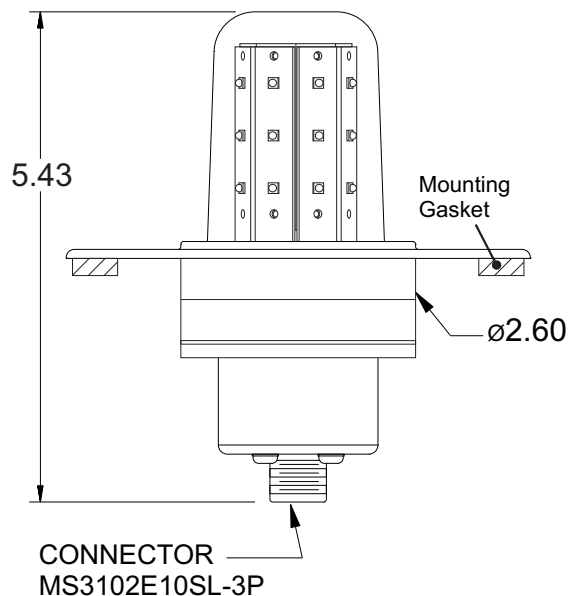
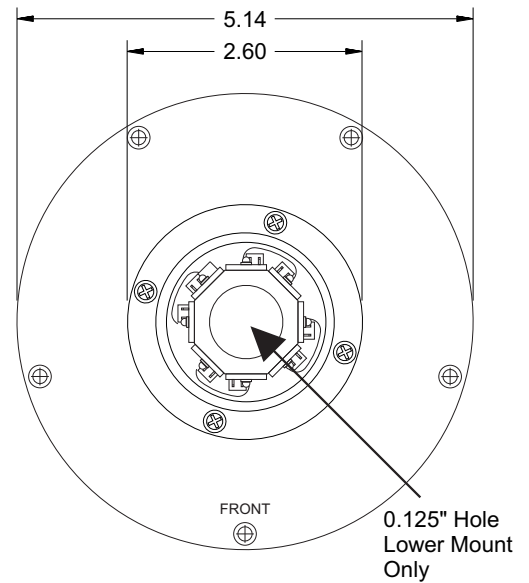

Aviation

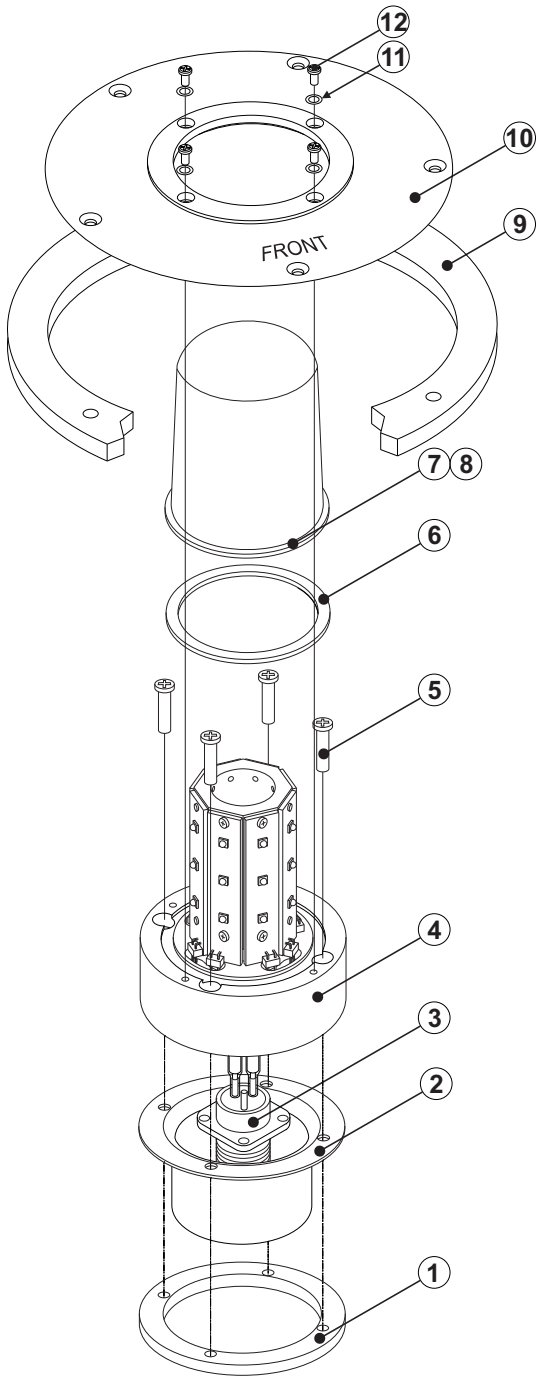

QTY	QTY	ITEM	PART NUMBER	DESCRIPTION
	*		01-0771410-08	MODEL 7141008 (28V) UPPER
	*		01-0771410-18	MODEL 7141018 (28V) LOWER
1	1	1	07-750976-100	NUTPLATE
1	1	2	11-450845-300	HOUSING, MACHINED
1	1	3	39-5903711-25	CONNECTOR, MS3102E10SL-3P
1	1	4		ASSY, 28V WHITE LED ANTI COLLISION LIGHT
4	4	5	14-0050503-35	SCREW, 6-32 X 1 1/4" PPHMS MS51957-35
1	1	6	38-0250885-00	GASKET, LENS
-	1	7	68-4971082A30	LENS, CLEAR LED ANTI-COLLISION HARDCOAT
1	-	8	68-4971082A31	LENS, CLEAR LED ANTI-COLLISION HARDCOAT W/DRAIN
1	1	9	38-0250225-00	SEAL, HR LT SERIES
1	1	10	07-571304-100	ADAPTER, 5-HOLE LENS RETAINER
4	4	11	16-0050506135	WASHER, #4 LOCK-SPRING MS35338-135
4	4	12	14-0050505-14	SCREW, 4-40 X 5/16" PPHMS MS51957-14

