

# WHELEN<sup>®</sup>

ENGINEERING COMPANY INC.

51 Winthrop Road  
 Chester, Connecticut 06412-0684  
 Phone: (860) 526-9504  
 Fax: (860) 526-2009  
 Internet: www.whelen.com  
 Sales/Service e-mail: aviation@whelen.com

## Installation Guide: Aviation model 9048201 P/N 01-0790482-01 LED Tail Position / Ground Recognition / Anti-Collision Light Assembly



TSO-C30c  
 TYPE III;  
 APPROVED

TSO-C96a  
 CLASS II;  
 APPROVED



*The conditions and tests required for TSO approval of this article are minimum performance standards. It is the responsibility of those installing this article either on or within a specific type or class of aircraft to determine that the aircraft installation conditions are within the TSO standards. TSO articles must have separate approval for installation in aircraft. The article may be installed only if performed under 14 CFR part 43 or the applicable airworthiness requirements.*

**SPECIFICATIONS:**

- Nominal Operational Voltage: .....28 VDC
- Input Current (with 7123403 Flasher):
- LED Tail Position Light: .....0.25 Amps
- LED Anti-Collision Light (Average): .....0.53 Amps
- LED Anti-Collision Light (Peak@0.25 sec.): .....2.8 Amps
- LED Ground Recognition Light (Average): .....0.13 Amps
- LED Ground Recognition Light (Peak@0.25 sec.): .....0.7 Amps
- Flashrate .....45± 5 per min.

**EQUIPMENT LIMITATIONS:**

An approved lighting system consists of three lights, one located on the tail and one located on each wingtip. The baseplate must be mounted parallel to the vertical and horizontal centerlines of the aircraft to project the patterns properly. The light assembly must be connected to flasher assembly, model 7123403.

The ground recognition light is a non-TSO function.

Certain types of installations may require additional testing.

**CONTINUED AIRWORTHINESS:**

The tail position light is designed with 4 LEDs. The anti-collision light is designed with 28 LEDs. The ground recognition light is designed with 4 LEDs. If any one LED fails, the unit must be repaired or replaced. **Note:** To reduce eye strain, use an optical filter (such as dark glasses or blue covering dome) during LED inspection.

Inspect the lens. Replace if there is excessive scratching, pitting, discoloration or cracking.

**Note:** The anti-collision light will automatically shut-off after 9-10 flashes if a failure is detected.

**INSTALLATION PROCEDURES:**

1. Using the mounting detail information on page 2 prepare the aircraft for means to secure the LED light assembly. Remove any existing mounting adapters.
2. Connect the light inputs according to the chart shown. Connections to be in accordance with FAA approved methods

3. Install the light assembly by securing to the aircraft using appropriate, approved hardware. Refer to page 2. Insure that all leads are clear of any obstructions, and secure as required. Insure that the gasket drain holes are oriented as shown on Page 2.
4. When necessary, waterproof the light base to aircraft. Apply single part silicone (RTV) or equivalent around any open area where water could get in. Do not cover the drain holes.
5. Check all avionics systems for interference from this installation.
6. A flight check should be performed by a properly certified pilot.
7. Update aircraft records, complete Form 337 and obtain FAA field approval for installation, as required.

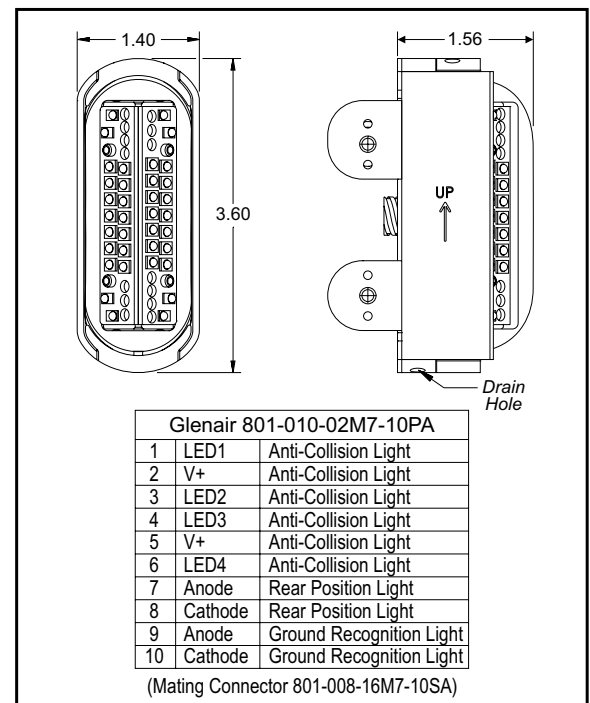

Aviation

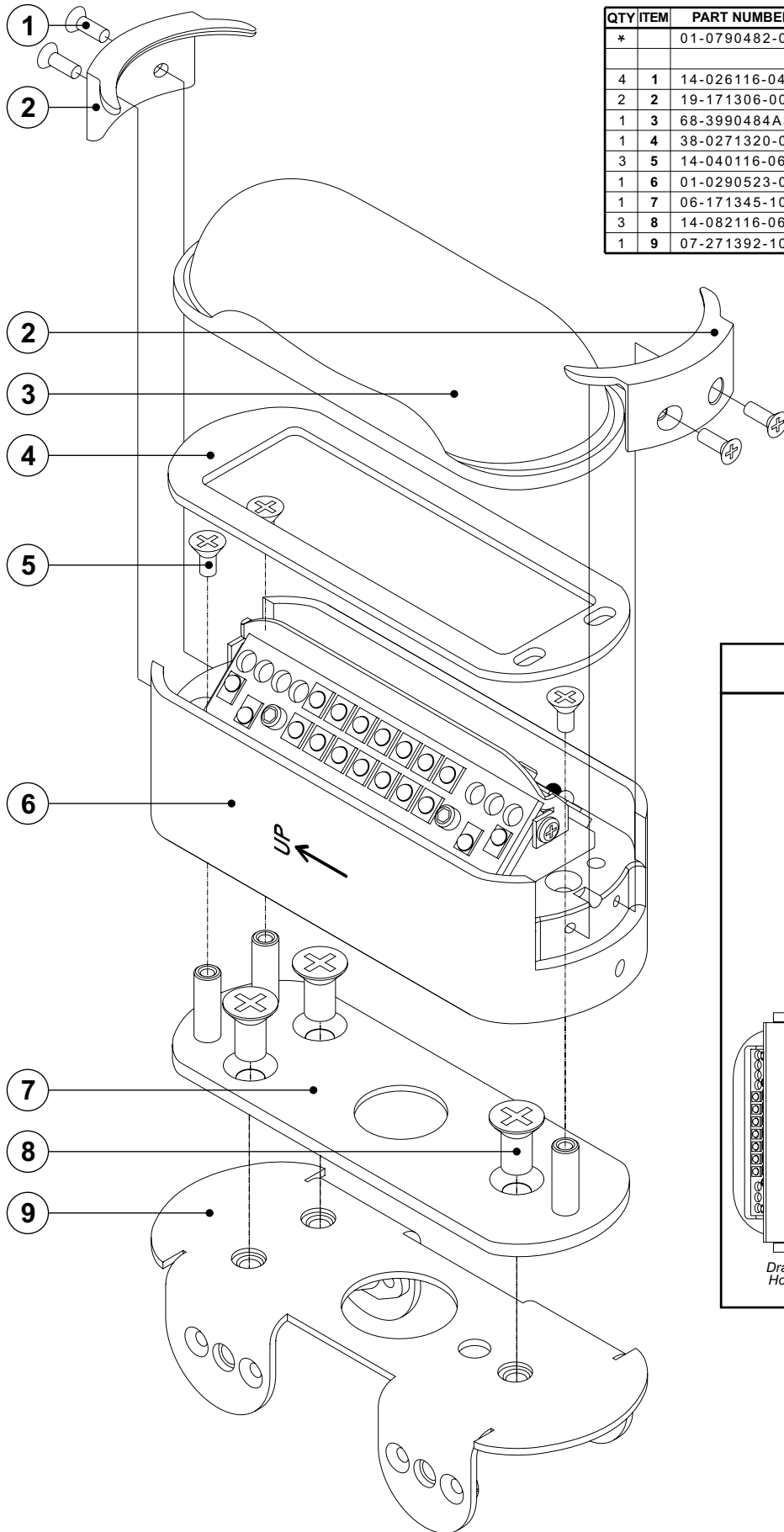

QTY	ITEM	PART NUMBER	DESCRIPTION
*		01-0790482-01	ASS'Y, TAIL/AC MODEL 9048201
4	1	14-026116-04P	SCREW, 2-56 X 1/4 P82FHMS SS
2	2	19-171306-000	RETAINER
1	3	68-3990484A30	LENS, HARDCOATED
1	4	38-0271320-00	GASKET, LENS
3	5	14-040116-060	SCREW, 4-40 X 3/8 PFHMS
1	6	01-0290523-00	ASS'Y, LIGHTHEAD MODEL 9048201
1	7	06-171345-100	BASE PLATE, MOUNTING MODEL 90482
3	8	14-082116-060	SCREW, #8-32 X 3/8 PFHMS
1	9	07-271392-100	BRACKET, MOUNTING MODEL 9048201

