

WHELEN®

ENGINEERING COMPANY INC.

51 Winthrop Road
 Chester, Connecticut 06412-0684
 Phone: (860) 526-9504
 Fax: (860) 526-2009
 Internet: www.whelen.com
 Sales/Service e-mail: aviation@whelen.com

Installation Guide: Aviation model 7123405 P/N 01-0771234-05 Flasher/Current Source



TSO-C30c
 TYPES I, II & III /
 TSO-C96a
 CLASS II
 APPROVED



The conditions and tests required for TSO approval of this article are minimum performance standards. It is the responsibility of those installing this article either on or within a specific type or class of aircraft to determine that the aircraft installation conditions are within the TSO standards. TSO articles must have separate approval for installation in aircraft. The article may be installed only if performed under 14 CFR part 43 or the applicable airworthiness requirements.

SPECIFICATIONS:

- Nominal Operational Voltage: 28 VDC
 (Operation from 22-32 VDC)
- Input Current (with 90645() Lighthead):
 - LED Forward Position Light..... 0.25 Amps
 - LED Tail Position Light..... 0.1 Amps
 - LED Anti-Collision Light (Pulse@.25 Sec.)..... 3.7 Amps
 - LED Anti-Collision Light (Avg.) 0.7 Amps

Flashrate 45 ±5 Per. Min.

EQUIPMENT LIMITATIONS:

An approved Anti-Collision / Position Light System consists of at least 2 flasher/current source units, each connected to a LED anti-collision and position lighthead such as Model 90645().

Certain types of installations may require additional testing.

CONTINUED AIRWORTHINESS:

If any bank of LEDs fail, the lighthead module should be checked. If the module checks good, replace the flasher.

Note: To reduce eye strain, use an optical filter such as dark glasses or a blue covering dome during LED inspection.

Note: The anti-collision light will automatically shut-off after 9-10 flashes if a failure is detected.

INSTALLATION PROCEDURES:

1. Consider areas or locations designated by the aircraft manufacturer. Check that breakers are properly rated.
2. Attach the flasher using the (4) 0.156 dia. mounting holes.
3. Connect the inputs according to the chart shown. Connect the cable from the lighthead to the flasher. Connections to be in accordance with FAA approved methods.
4. Check all avionic systems for interference from the installation.
5. A flight check should be performed by a certified pilot
6. Update aircraft records, complete form 337 and obtain FAA field approval for installation, as necessary

Note: SYNC is a low power, bi-directional control signal. Connecting to the synchronize signal of any Whelen LED anti-collision assembly will cause the lights to flash at the same time. If synchronization is not necessary, the connection may be left open.

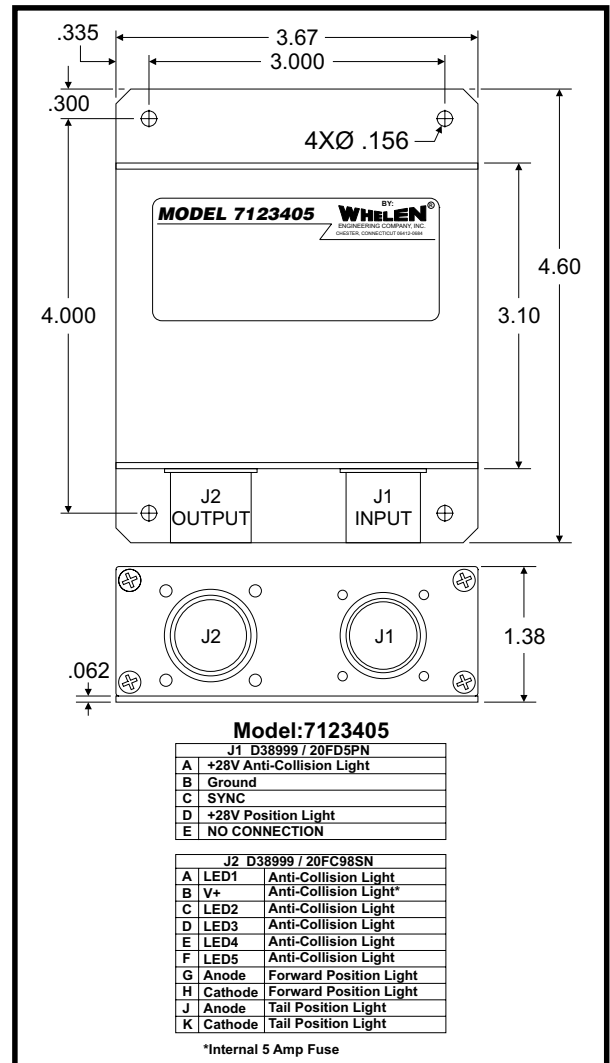

Aviation

For warranty information regarding this product, visit www.whelen.com/warranty