

WHELEN[®]

ENGINEERING COMPANY INC.

51 Winthrop Road
Chester, Connecticut 06412-0684
Phone: (860) 526-9504
Fax: (860) 526-2009
Internet: www.whelen.com
Sales/Service e-mail: aviation@whelen.com

Installation Guide: Aviation model(s): 9040091, 9040092 P/N: 01-0790400-91, 01-0790400-92 LED Position/Anti-Collision/Tail Light Ass'y



TSO-C30c
TYPES I, II & III;
APPROVED

TSO-C96a
CLASS II;
APPROVED



The conditions and tests required for TSO approval of this article are minimum performance standards. It is the responsibility of those installing this article either on or within a specific type or class of aircraft to determine that the aircraft installation conditions are within the TSO standards. TSO articles must have separate approval for installation in aircraft. The article may be installed only if performed under 14 CFR part 43 or the applicable airworthiness requirements.

SPECIFICATIONS:

Nominal Operational Voltage:	28 VDC
Input Current:	
LED Forward Position Light	0.25 Amps (Red)
	0.21 Amps (Green)
LED Anti-Collision Light (Peak@0.25 sec) .	4 Amps
LED Anti-Collision Light (Average)	0.75 Amps
LED Tail Position Light.....	0.25 Amps
Flashrate:	45± 5 per min.
Total Weight	1.0 lbs.

EQUIPMENT LIMITATIONS:

An approved lighting system consists of two lights, one located on each wingtip. The baseplate must be mounted parallel to the vertical and horizontal centerlines of the aircraft to project the patterns properly. A separate flasher unit is required per light.

CONTINUED AIRWORTHINESS:

The forward position light is designed with 3 LED's. The tail position light is designed with 3 LED's. The Anti-Collision light is designed with 26 LED's. If any one LED fails, the unit must be repaired or replaced. Inspect the lens. Replace if there is excessive scratching, pitting, discoloration or cracking.

Note: The anti-collision light will automatically shut-off after 9-10 flashes if a failure is detected.

INSTALLATION PROCEDURES:

The following information is to assist you in installing a Whelen Anti-Collision / Position light system.

1. Choose the appropriate Model 90400() replacement light assembly.
2. The installation procedure described in the following text will be confined to a single light installation, but is identical for multiple light installations.
3. Connect the anti-collision inputs and the position light inputs according to the chart shown. Connections to be in accordance with FAA approved methods.

4. Using appropriate hardware, install light assembly and insure that all leads are clear of any obstructions and ty-rap as required. Secure light assembly, using vibration resistant threaded fasteners.
5. Reinstall the lens.
6. Check all avionics systems for interference from this installation.
7. A flight check should be performed by a properly certified pilot.
8. When necessary, waterproof the light base to aircraft. Apply single part silicone (RTV) or equivalent around any open area where water could get in.
9. Update aircraft records, complete Form 337 and obtain FAA field approval for installation, as necessary.

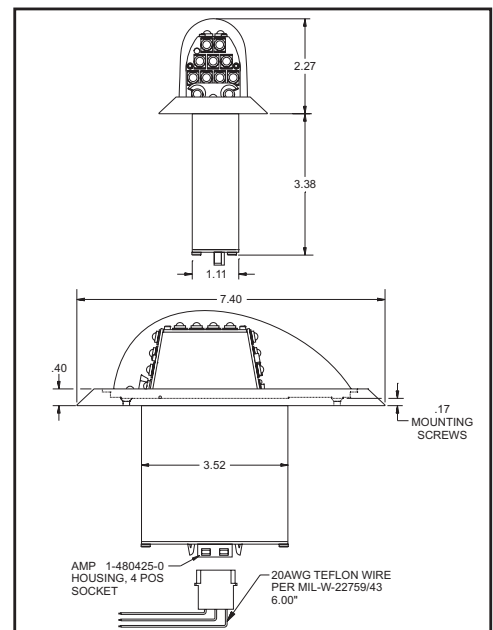

Aviation

QTY	QTY ITEM	PART NUMBER	DESCRIPTION
*		01-0790400-91	ASSY, GREEN LED FINAL MODEL 9040001
*		01-0790400-92	ASSY, RED LED FINAL MODEL 9040002
1	1	46-0731186-00	ASSY, 28V PIGTAIL 6"
-	1	01-0290412-91	ASSY, GREEN MODULE
1	-	01-0290412-92	ASSY, RED MODULE
1	1	38-0290430-00	GASKET, LENS
1	1	68-3990413A30	LENS, PLASTIC, CLEAR HARDCOAT
1	1	19-150941-000	RETAINER, TAIL
4	4	14-040116-04P	SCREW, 4-40 X 1/4 PFH 82 CSNK
1	1	19-150940-000	RETAINER, FORWARD

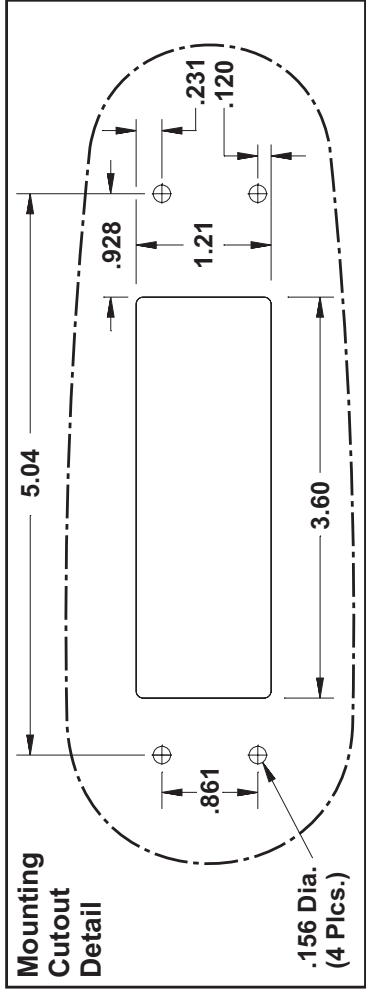

Wiring Pinouts by Model

Models:
 9040091
 9040092

Position	28V	Pin 1
Anti-Collision	28V	Pin 2
SYNC	N/C	N/C
GROUND		Pin 4

