



WHELEN AEROSPACE TECHNOLOGIES

Phone: (860) 526-9504
 Fax: (860) 526-2009
 Internet: www.flyWAT.com
 Sales/Service e-mail: info@flyWAT.com

**Installation Guide/ICA:
 Model 90520()-series
 Model(s) 9052004, 9052014
 P/N(s):01-0790520-04, 01-0790520-14
 LED Flashing Split Anti-Collision
 Light Assembly**

TSO-C96a
 CLASS III;
 APPROVED

The conditions and tests required for TSO approval of this article are minimum performance standards. Those installing this article either on or within a specific type or class of aircraft must determine that the aircraft installation conditions are within the TSO standards which include any accepted integrated non-TSO functions. TSO articles and any accepted integrated non-TSO function(s) must have separate approval for installation in an aircraft. The article may be installed only according to 14 CFR part 43 or the applicable airworthiness requirements.

OPERATING INSTRUCTIONS:

Operational Voltage: 28 VDC nominal
Average Input Current: 0.45 Amps
Pulse Input Current: 2.0 Amps @ .3 Seconds

The Model 90520 series LED Flashing Split Anti-collision Light Assembly meets the requirements of FAR 91.205(c)(3).

AIRWORTHINESS LIMITATIONS: The Airworthiness Limitations section is FAA approved and specifies inspections and other maintenance required under §43.16 and §91.403 of the Federal Aviation Regulations, unless an alternative program has been approved.

No airworthiness limitations are associated with the installation of the LED anti-collision light.

CONTINUED AIRWORTHINESS: The 90520 series LED Flashing Split Anti-collision Light Assembly is designed with 4 vertical columns consisting of 4 red LEDs each and 4 vertical columns consisting of 3 white LEDs each. Should any one LED or any vertical column fail, the unit must be repaired or replaced.

Inspect the lens, replace if there is excessive scratching, pitting, discoloration or cracking. For additional lens maintenance detail see SAE ARP5637.

PERIODIC INSPECTIONS: An annual inspection shall be performed unless the OEM specifies a shorter interval.

INSTALLATION PROCEDURES: The following information is to assist in the installation of a WAT LED Flashing Split Anti-collision Light System.

1. The installation procedure described in the following text will be confined to a single light installation, but is identical for multiple light installations.
2. Using the "suggested mounting hole pattern" prepare the aircraft for means to secure the LED Flashing Split Anti-collision Light assembly. Remove any existing mounting adapters.
3. 28 VDC (+) and (-) ground leads equipped with an appropriate sized breaker to be supplied to the LED Flashing Split Anti-collision Light Assembly System. Both leads must be connected by an approved FAA connection. Insure that the wire leads are clear of any obstructions and ty-wrap as required.
4. Install the light assembly by securing to the aircraft using appropriate, approved hardware. Refer to page 2.
5. All inverted (bottom) mounted units shall require waterproofing of the flasher base assembly to the aircraft.
6. Check all avionics systems for interference from this installation.
7. A flight check should be performed by a properly certified pilot.
8. If required, update aircraft records utilizing FAA Field Approval (Form 337) or equivalent.

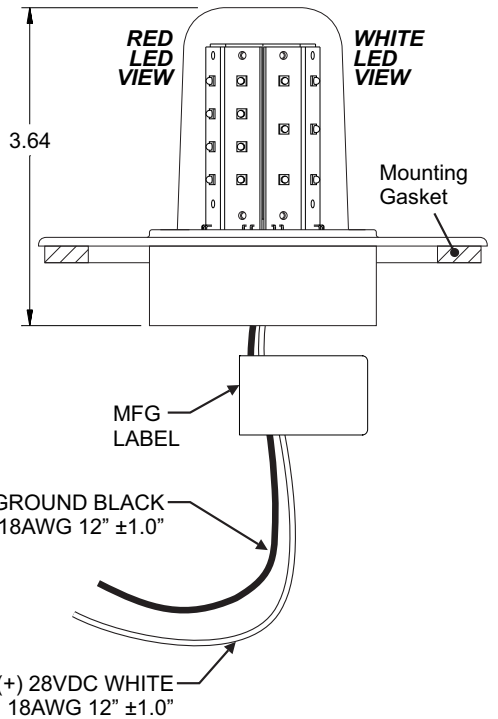
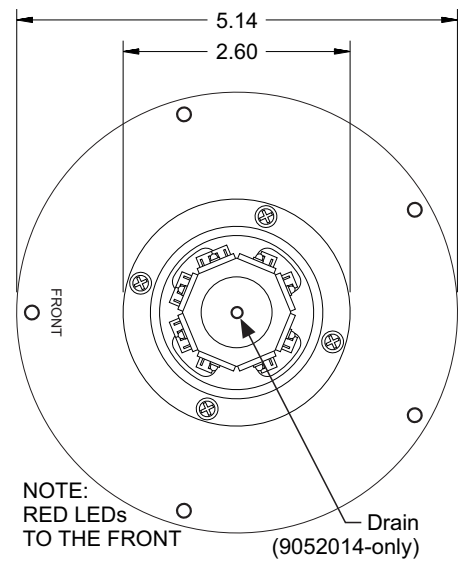

Aviation

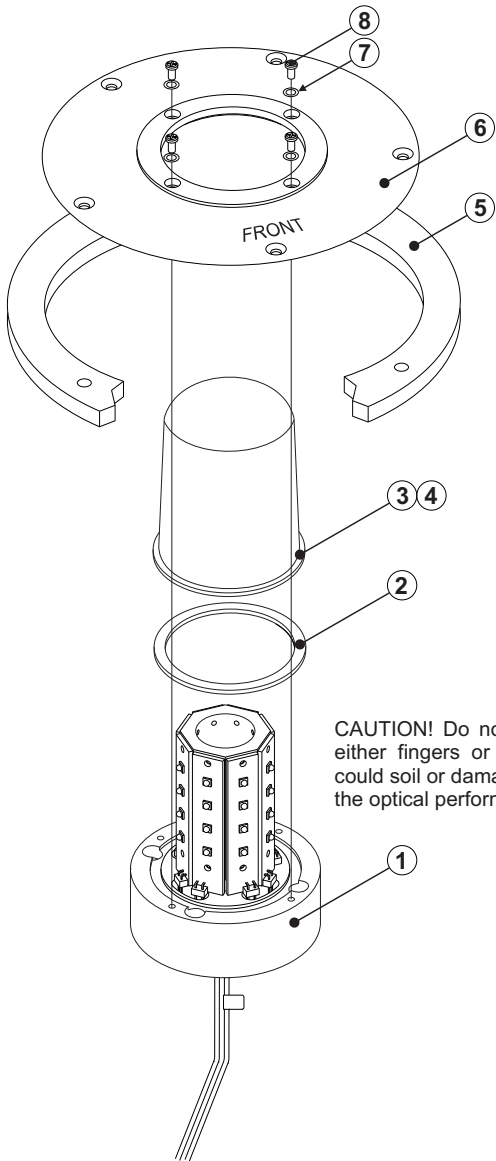

CAUTION! Do not touch the LEDs with either fingers or sharp objects, as this could soil or damage the LEDs and effect the optical performance of the light.

QTY	QTY	ITEM	PART NUMBER	DESCRIPTION
	*		01-0790520-04	MODEL 9052004 (28V) UPPER
*			01-0790520-14	MODEL 9052014 (28V) LOWER
1	1	1		ASSY, 28V LED ANTI COLLISION LIGHT 90520
1	1	2	38-0250885-00	GASKET, LENS
-	1	3	68-4971082A30	LENS, CLEAR LED ANTI-COLLISION HARDCOAT
1	-	4	68-4971082A31	LENS, CLEAR LED ANTI-COLLISION HARDCOAT w/DRAIN
1	1	5	38-0250225-00	SEAL, HR LT SERIES
1	1	6	07-571304-100	ADAPTER, 5-HOLE LENS RETAINER CLEAR IRIDITE
4	4	7	16-0050506135	WASHER, #4 LOCK-SPRING MS35338-135
4	4	8	14-0050505-14	SCREW, 4-40 X 5/16 PPHMS MS51957-14

