

WHELEN[®]

ENGINEERING COMPANY INC.

Route 145, Winthrop Road,
 Chester, Connecticut 06412
 Phone: (860) 526-9504
 Fax: (860) 526-2009
 Internet: www.whelen.com
 Sales/Service e-mail: aviation@whelen.com

Installation Guide:
 Model 70900()-series
 Model 7090000
 7090001

P/N:01-0770900-00
 01-0770900-01

LED Flashing Anti-Collision Light Assembly



TSO-C96a CLASS III
 APPROVED



The conditions and tests required for TSO approval of this article are minimum performance standards. It is the responsibility of those installing this article either on or within a specific type or class of aircraft to determine that the aircraft installation conditions are within the TSO standards. TSO articles must have separate approval for installation in aircraft. The article may be installed only if performed under 14 CFR part 43 or the applicable airworthiness requirements.

OPERATING INSTRUCTIONS:

Operational Voltage: 14 / 28 VDC nominal
Average Input Current: 0.85 / 0.425 Amps
Peak Input Current: 4.5 / 2.25 Amps @ .25 Seconds

The Model 70900 series LED anti-collision light assembly meets the requirements of FAR 91.205(c)(3).

CONTINUED AIRWORTHINESS: The 70900 series LED anti-collision light assembly is designed with 10 vertical columns consisting of 3 LEDs each. Should any one LED or any vertical column fail, the unit must be repaired or replaced.

INSTALLATION PROCEDURES: The following information is to assist in the installation of a Whelen LED Flashing Anti-collision Light System.

1. The installation procedure described in the following text will be confined to a single light installation, but is identical for multiple light installations.
2. Using the "suggested mounting hole pattern" prepare the aircraft for means to secure the LED Flashing Anti-collision Light assembly.
3. 14 / 28 VDC (+) and (-) ground leads equipped with an appropriate sized breaker to be supplied to the LED Flashing Anti-collision Light Assembly System. Both leads must be connected by an approved FAA connection. Insure that the wire leads and the pressure venting tube are all clear of any obstructions and ty-wrap as required. The pressure venting tube may be trimmed to minimum length of 1" from base.
4. Install the light assembly by first removing the lens. Insert the appropriate hardware through the counter-bored holes, secure the assembly and re-install the lens screws with 5-7 in./lbs. of torque.
5. Check all avionics systems for interference from this installation.
6. A flight check should be performed by a properly certified pilot.
7. All inverted (bottom) mounted units shall require waterproofing of the mounting hardware. An application of single-part silicone (RTV) or equivalent applied over top of the mounting hardware, after installation, is recommended. Reference page 2 for an illustration. Inverted and/or standard mounted units, when necessary, may require waterproofing around any open area where water could get in. Specifically, the lens to the flasher base assembly, and the flasher base assembly to the aircraft. **Note:** It is permissible to drill a 1/8" hole in the center of the lens for bottom mount units.
8. Update aircraft records, complete Form 337 and obtain FAA field approval for installation.

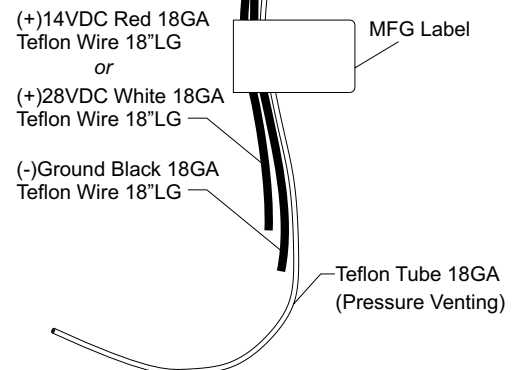
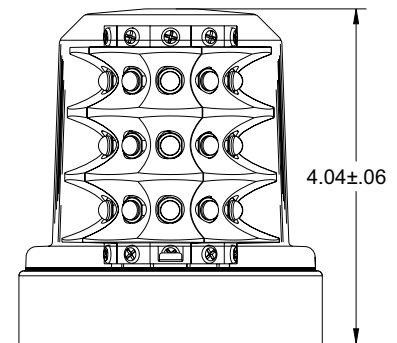
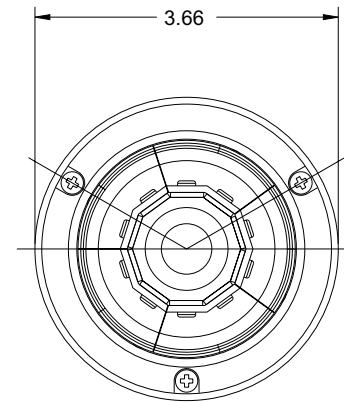

Aviation

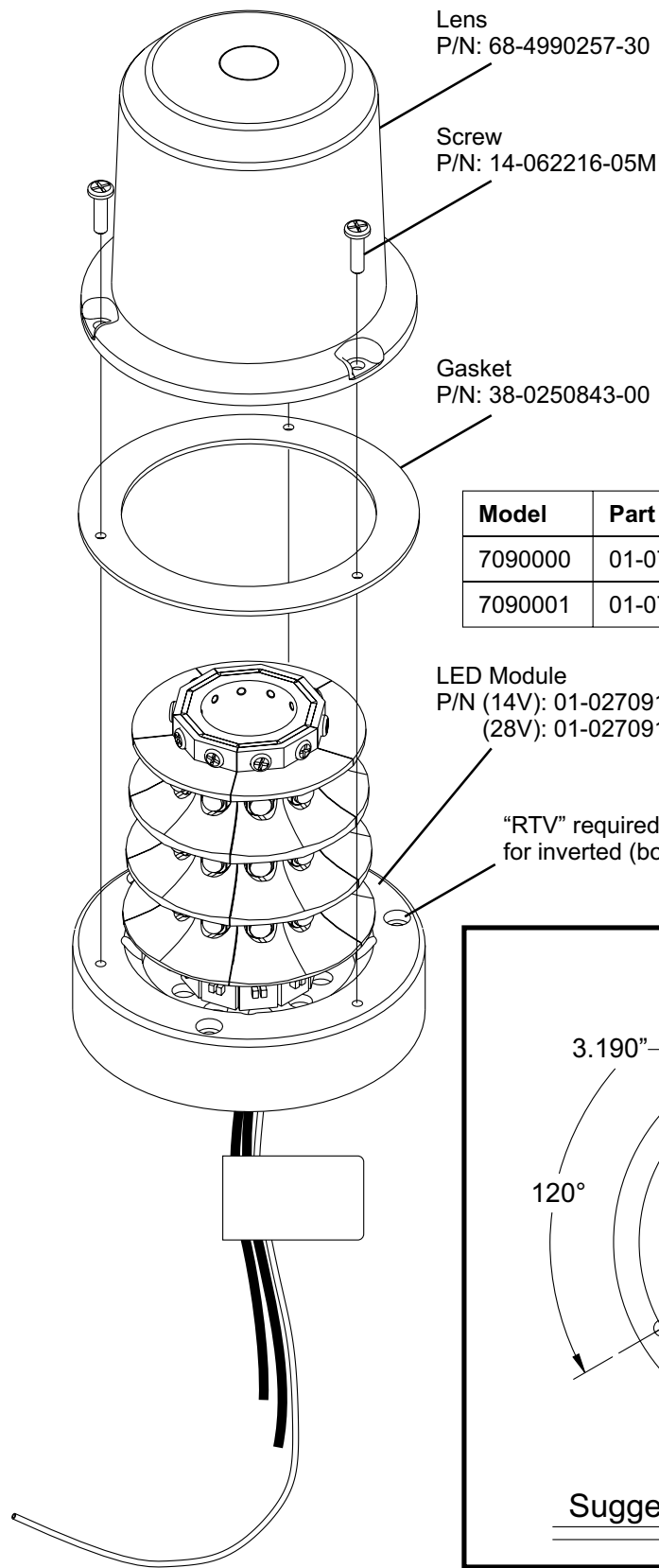

Model	Part Number	Description
7090000	01-0770900-00	14VDC, No Connector
7090001	01-0770900-01	28VDC, No Connector

