

5 Colour Recessed Downlight Installation Instructions



Product Specifications

Model No.	HCP-81241009	HCP-81341009	HCP-81241013	HCP-81341013	HCP-81241017	HCP-81341017
Material	Aluminium + Plastic		Aluminium + Plastic		Aluminium + Plastic	
Colour	Black	White	Black	White	Black	White
IC Rating	IC-4		IC-4		IC-4	
IP Rating	IP44 - Front of Fitting Only		IP44 - Front of Fitting Only		IP44 - Front of Fitting Only	
Cut Out	100mm x 100mm		100mm x 100mm		100mm x 100mm	
Tilt	Yes - 20°		Yes - 20°		Yes - 20°	
Input Voltage	240v (Remote Driver)		240v (Remote Driver)		240v (Remote Driver)	
Protection Class	2 (No Earth Required) <input type="checkbox"/>		2 (No Earth Required) <input type="checkbox"/>		2 (No Earth Required) <input type="checkbox"/>	
Lamp Base	Built in LED		Built in LED		Built in LED	
Lamp Wattage	1x 9w		1x 13w		1x 17w	
Colour Temp	5-Colour - 2.7k, 3k, 4k, 5k, 5.7k		5-Colour - 2.7k, 3k, 4k, 5k, 5.7k		5-Colour - 2.7k, 3k, 4k, 5k, 5.7k	
Lumens	647lm, 653lm, 734lm, 750lm, 769lm		980lm, 965lm, 959lm, 1072lm, 1089lm		1191lm, 1202lm, 1297lm, 1365lm, 1397lm	
CRI	> 90		> 90		> 90	
Dimmable	Dali Dimmable		Dali Dimmable		Dali Dimmable	
Warranty	5 Years Replacement*		5 Years Replacement*		5 Years Replacement*	

9w + 13w Dimensions

Cut Out: 100mm x 100mm

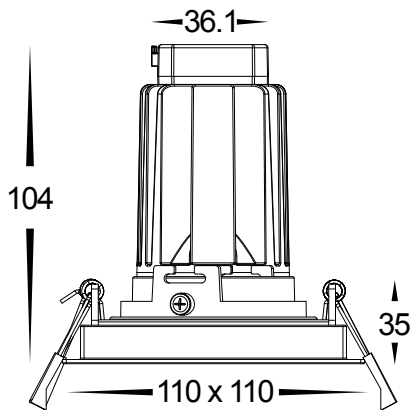

17w Dimensions

Cut Out: 100mm x 100mm

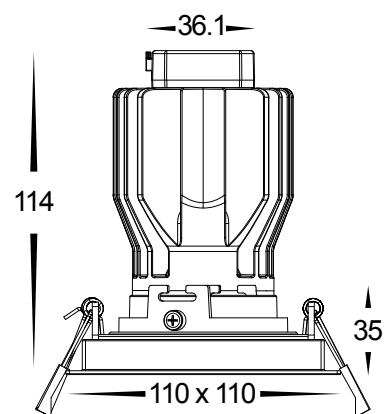

Important Safety Issues:

- This product must be installed by a qualified electrician according to AS/NZS 3000.
- Ensure all electrical mains are disconnected before any installation.
- Modification of this product will void any warranty.
- Only LED Fitting can be installed under insulation, LED Driver must not be covered to allow for ventilation.
- This fixture must not be installed with loose fill insulation such as macerated paper and wool. LED driver must be mounted above any insulation covering the fixture.
- Havit Commercial does not take responsibility for wrong installation, incorrect use, or use of installation material that does not belong to the system.
- Aluminium and 304SS fittings must not be installed within 5km of any salt water environments.
- All o-rings and seals must be in place correctly to maintain warranty
- This form may be updated at any time due to product improvements, please check online installation form for most current version.

Steps for Installation:

1. Make sure that the electrical circuit is free of voltage (master switch off)
2. Cut out hole using dimensions in table and on line drawings above for model purchased making sure each hole is not under joist or pipes.
3. Fitting is provided with flex and plug, Plug cable into plug base installed earlier.
4. Connect Dali Cable
5. Fitting is preset to 3000k, to change slide switch on back of fitting to desired colour temperature.
6. Before installing downlight, Make sure LED Driver is not covered by any insulation.
7. Pull back springs on fitting and insert into hole.
8. Once fitting is in hole, release clips, These springs will hold fitting in place.
9. All connections must be carried out carefully, inspect all contacts before switching back on the electric circuit.

Sample Installation Diagram:

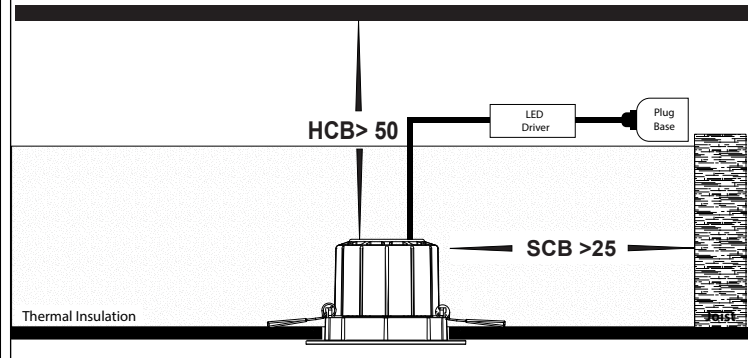

Must be installed by a licensed electrician

Contact Details:

8/133 Beauchamp Road
Matraville NSW 2036
Australia
Tel: 02 9381 8383
Email: sales@havitcommercial.com.au
Web: www.havitcommercial.com.au

Warranty Terms & Conditions*



www.havitcommercial.com.au

