

Square Pendants Installation Instructions



Product Specifications

Model No.	HCP-672850	HCP-673850
Name	Proline Square	
Cable Length	3000mm Adjustable	
Material	Aluminium	
Colour	Black	White
IP Rating	IP20	
Input Voltage	240v AC	
Lamp Base	Built in LED	
Lamp Wattage	1x 65w	
Colour Temp	TRI Colour - 3000k, 4000k, 5500k	
Lumens	5230lm, 5350lm, 5670lm	
CRI	> 80	
Wiring	Parallel	
Dimmable	Yes - Triac Dimmable	
Warranty	5 Years Replacement*	

Dimensions

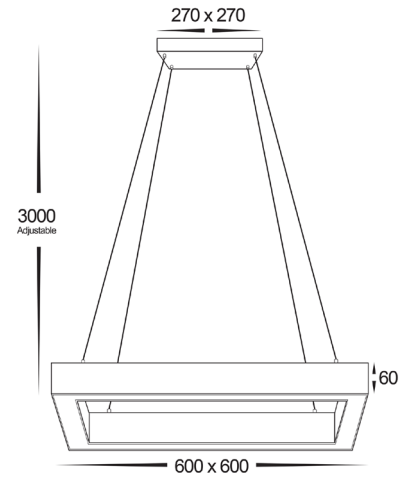

Important Safety Issues:

- This product must be installed by a qualified electrician according to AS/NZS 3000.
- Ensure all electrical mains are disconnected before any installation.
- Modification of this product will void any warranty.
- Havit Commercial does not take responsibility for wrong installation, incorrect use, or use of installation material that does not belong to the system.
- Aluminium and 304SS fittings must not be installed within 2km of any salt water environments.
- This form may be updated at any time due to product improvements, please check online installation form for most current version.

Steps for Installation:

1. Make sure that the electrical circuit is free of voltage (master switch off)
2. Remove mounting bracket from canopy by removing screws on side and setting aside.
3. Install bracket in desired location using appropriate screws for application.
4. Connect the cable: Using cable with earth, Connect earth first then live and neutral.
5. Adjust length of cable to desired height
6. Reattach canopy to bracket with screws set aside earlier making sure these are tight.
7. Fitting is preset to 3000k, To change slide switch on side of canopy to desired colour temperature. This step must be done only when fitting is OFF.
8. All connections must be carried out carefully, inspect all contacts before switching back on the electric circuit.

Must be installed by a licensed electrician

Contact Details:

8/133 Beauchamp Road
Matraville NSW 2036
Australia

Tel: 02 9381 8383
Email: sales@havitcommercial.com.au
Web: www.havitcommercial.com.au

Warranty Terms & Conditions*



Additional Information

