

# 1.5w 1 Way Deck or Inground Light Installation Instructions



## Product Specifications

Model No.	HCP-271123	HCP-271124	HCP-271125	HCP-272123	HCP-272124	HCP-272125	HCP-276123	HCP-276124	HCP-276125
Material	316 Stainless Steel			316 Stainless Steel			Solid Brass		
Colour	Stainless Steel			Black			Antique Brass		
Cut Out	15mm to 40mm			15mm to 40mm			15mm to 40mm		
Trafficable	Up to 500kgs			Up to 500kgs			Up to 500kgs		
IP Rating	IP65			IP65			IP65		
IK Rating	IK10			IK10			IK10		
Input Voltage	24v DC			24v DC			24v DC		
Protection Class	3 (no earth required)			3 (no earth required)			3 (no earth required)		
Lamp Base	Built in LED			Built in LED			Built in LED		
Lamp Wattage	1x 1.5w			1x 1.5w			1x 1.5w		
Colour Temp	3000k	4000k	5000k	3000k	4000k	5000k	3000k	4000k	5000k
Lumens	80lm	85lm	90lm	80lm	85lm	90lm	80lm	85lm	90lm
CRI	80+			80+			80+		
Dimmable	No			No			No		
Warranty	5 Years Replacement*			5 Years Replacement*			5 Years Replacement*		

### Important Safety Issues:

- This product must be installed by a qualified electrician according to AS/NZS 3000.
- Ensure all electrical mains are disconnected before any installation. Modification of this product will void any warranty.
- Havit Commercial does not take responsibility for wrong installation, incorrect use, or use of installation material that does not belong to the system.
- All electrical connections must be watertight, If a watertight connection is not done, Warranty will be voided.
- When installing low voltage fittings, Voltage to fitting must be within +or- 5% of voltage required and cannot be installed more than 25m from LED Driver, if not within this allowance warranty will be voided.
- All o-rings and seals must be in place correctly to maintain warranty.
- These instructions may be updated at any time due to product improvements, Please visit website for most current installation instructions.

### Dimensions

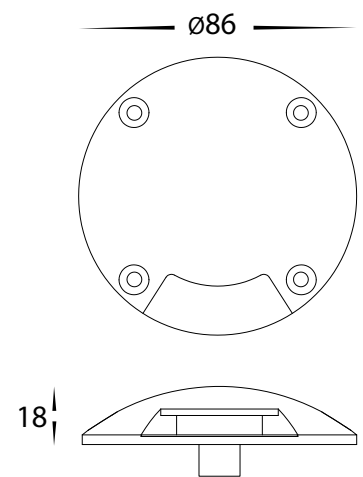

### Steps for Installation:

1. Make sure that the electrical circuit is free of voltage (master switch off)
2. Make hole in desired location using measurements above in table.
3. Insert cables through hole ready for connection.
4. Connect the cable -
5. Use an appropriate 24v DC LED Driver - DO NOT CONNECT LIGHT FITTING DIRECT TO 240V
6. Strip back cable on both the fitting and cable run and twist the positive cable from fitting to positive on the cable run, then connect neutral from fitting to neutral on the cable run.
7. Solder all joins using solder with either a heat gun or butane gas torch.
8. Cover connections using an adhesive lined heat shrink or gel cap to make connection watertight. (failure to do this step will void warranty)
9. Push connected cables into hole and place cover over led panel.
10. Mark holes where they need to be installed and remove cover.
11. Drill holes to the dimension of wall plugs provided if being installed into brick or concrete, If installing into timber, Pre-drill small hole to make attaching screws easier.
12. Place cover over led panel and attach screws and tighten.
13. All connections must be carried out carefully, inspect all contacts before switching back on the electric circuit.

**Must be installed by a licensed electrician**

### Contact Details:

8/133 Beauchamp Road  
Matrville NSW 2036  
Australia  
Tel: 02 9381 8383  
Email: sales@havitcommercial.com.au  
Web: www.havitcommercial.com.au

### Warranty Terms & Conditions\*



[www.havitcommercial.com.au](http://www.havitcommercial.com.au)

