

SQUARE 595MM X 595MM BACKLIT LED PANELS

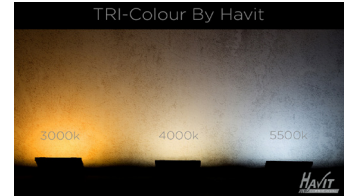
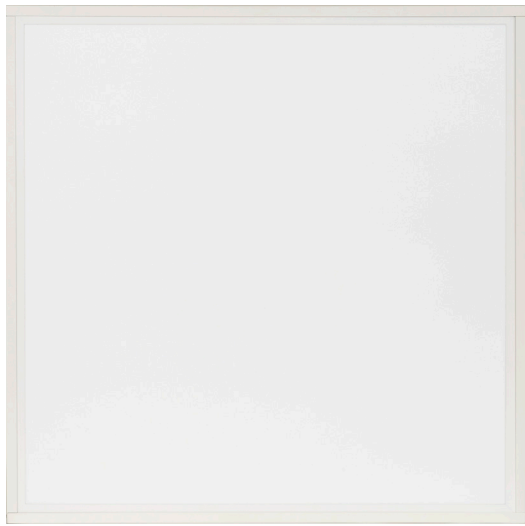

40W SQUARE 595MM X 595MM PANELS

MATERIAL	ALUMINIUM + PC
COLOUR / FINISH	WHITE
COLOUR TEMP	3000K 4000K 5500K (TRI-COLOUR)
LUMEN OUTPUT	2900LM 3100LM 3300LM
INPUT VOLTAGE	240V AC (REMOTE DRIVER WITH FLEX AND PLUG)
BUILT IN LED	40W
DIMMING	NON DIMMABLE TRIAC DALI
CRI	RA >90
BEAM ANGLE	120°
IP RATING	IP20
WARRANTY	5 YEARS REPLACEMENT

ALUMINIUM WHITE

HCP-173400-S-ND NON DIMMABLE	3000K	2900LM	40W LED
	4000K	3100LM	
	5500K	3300LM	
HCP-173400-S TRIAC DIMMABLE	3000K	2900LM	40W LED
	4000K	3100LM	
	5500K	3300LM	
HCP-173400-S-DALI DALI DIMMABLE	3000K	2900LM	40W LED
	4000K	3100LM	
	5500K	3300LM	

SURFACE MOUNT & RECESSED KITS

	HCP-17340-S-REC	Recessed kit
	HCP-17340-S-SM Can only be used with HCP-173400-S-ND	Surface Mounted kit
	HCP-17341-S-SM	Surface Mounted kit

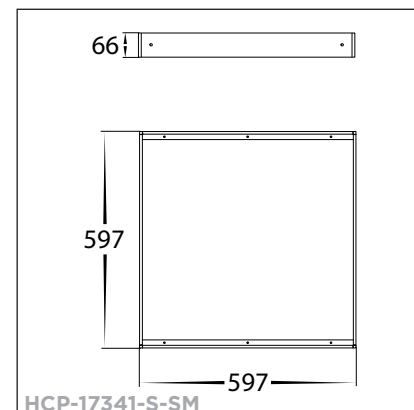
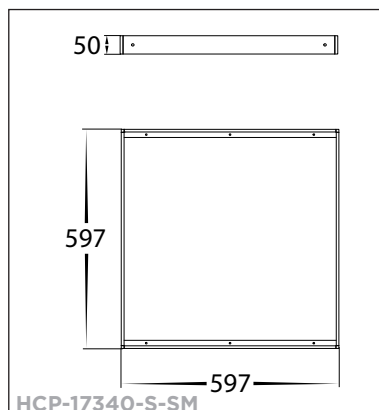
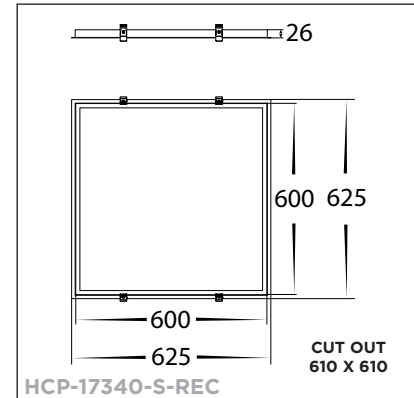
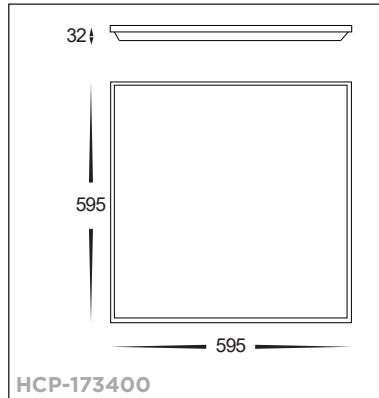
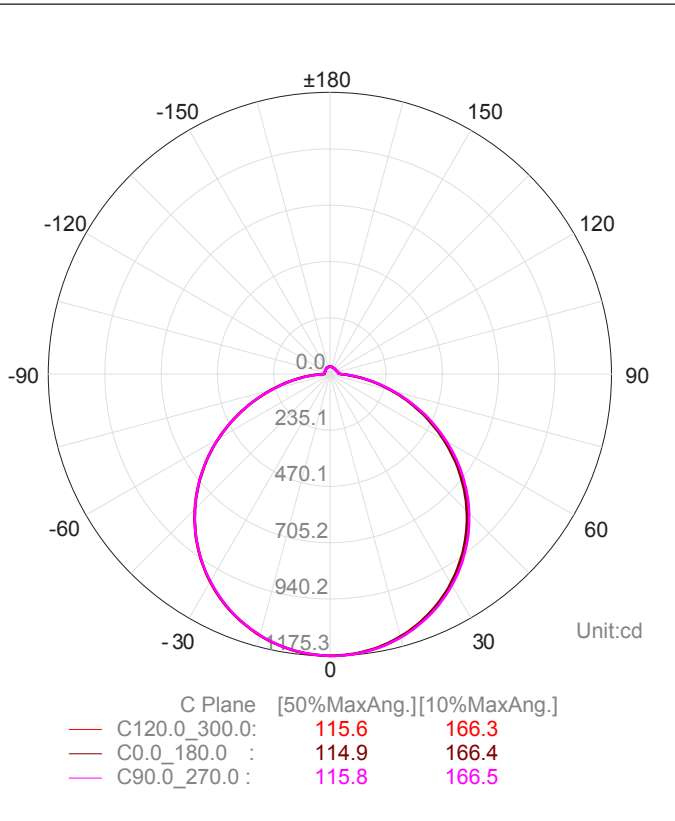

PHOTOMETRICS



Web: www.havitcommercial.com.au
 Email: sales@havitcommercial.com.au
 Phone: 02 9381 8383

ADDRESS: 8/133 Beauchamp Road, Matraville, N.S.W., 2036



Warranty Terms & Conditions



Website