

6W-9W THREE CIRCUIT TRACK HEADS

PRODUCT SPECIFICATIONS

| | |
|-----------------------|---|
| MATERIAL | ALUMINIUM |
| COLOUR / FINISH | MATT BLACK MATT WHITE |
| TRACK TYPE | 3 CIRCUIT 4 WIRE |
| COLOUR TEMP | 3000K 4000K 5000K (TRI-COLOUR) |
| LUMEN OUTPUT | 526LM-742LM 562LM-797LM 559LM-778LM |
| INPUT VOLTAGE | 240V AC |
| BUILT IN LED | 6W OR 9W LED (SELECTABLE ON FITTING) |
| DIMMING | TRIAC / PHASE CUT DIMMABLE |
| CRI | RA >90 |
| BEAM ANGLE | 60° |
| UGR RATING | <28 |
| LAMP EXPECTANCY | >50000HRS |
| IP RATING | IP20 |
| OPERATING TEMPERATURE | -10° TO 40° CELCIUS |
| LED CHIP TYPE | BRIDGELUX |
| WARRANTY | 5 YEARS REPLACEMENT |



PRODUCT ORDERING

ALUMINIUM BLACK

| | | |
|-------------|-------|-------------|
| HCP-1020914 | 3000K | 526LM-742LM |
| | 4000K | 562LM-797LM |
| | 5000K | 559LM-778LM |

ALUMINIUM WHITE

| | | |
|-------------|-------|-------------|
| HCP-1030914 | 3000K | 526LM-742LM |
| | 4000K | 562LM-797LM |
| | 5000K | 559LM-778LM |

OPTIONAL MAGNETIC REFLECTORS



GOLD - HCP-1050964-GLD

CHROME - HCP-1050964-CHR

BLACK - HCP-1050964-BLK

PHOTOMETRICS

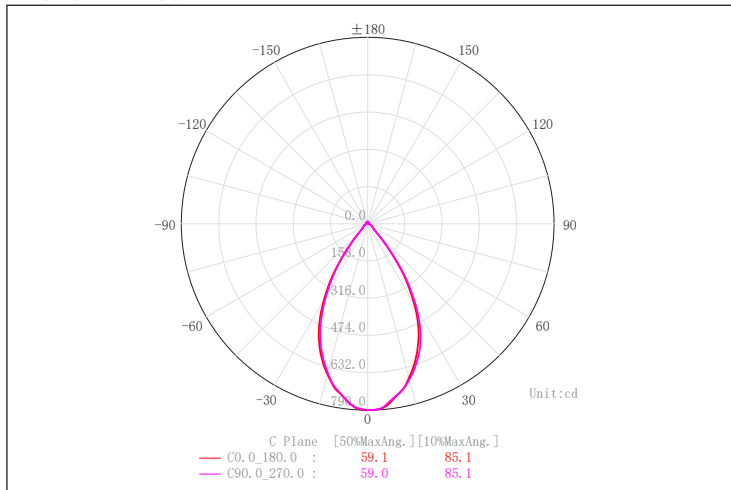

DIMENSIONS

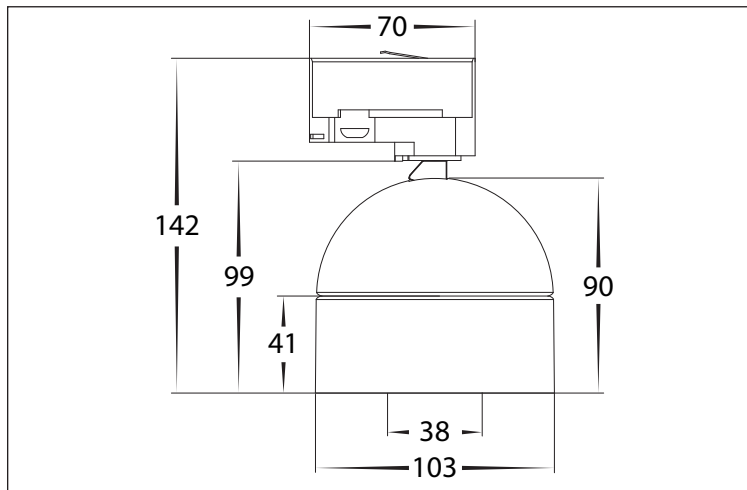

PHOTOMETRICS

