

WEIGHT ONLY OR  
PRICE COMPUTING SCALE

CHECKOUT APPLICATION

# DPOS-400 series

Dimensions  
DATA IN mm

A	50
B	275
C	65
D	345
E	420
F	45

Plate (stainless steel):  
L300 x W230 mm

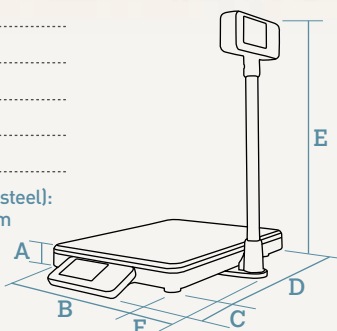

LCD  
GRAPHIC  
DISPLAY



RS-232



USB



METROLOGICAL  
VERIFICATION  
OPTIONAL (EU)

## Models

### Flat Format

	Vendor Display	Buyer Display	Communication protocols	Power through a USB	Capacity / Accuracy	Reference
<b>DPOS-400 F - 1 DISP.</b>	LCD Graphic	-	60, upgradeable	Mains / Others	6 kg / 2 g - 15 kg / 5 g	7POS00LNE __
<b>DPOS-400 F - 2 DISP.</b>	LCD Graphic	LCD Graphic	60, upgradeable	Mains / Others	6 kg / 2 g - 15 kg / 5 g	7POSPP0LNE __

### Pole Format

	Vendor Display	Buyer Display	Communication protocols	Power through a USB	Capacity / Accuracy	Reference
<b>DPOS-400 P - 1 DISP.</b>	LCD Graphic	-	60, upgradeable	Mains / Others	6 kg / 2 g - 15 kg / 5 g	7POST00LNE __
<b>DPOS-400 P - 2 DISP.</b>	LCD Graphic	LCD Graphic	60, upgradeable	Mains / Others	6 kg / 2 g - 15 kg / 5 g	7POSTT0LNE __
<b>DPOS-400 P - 2 DISP.</b> <i>(1 in base and 1 in pole)</i>	LCD Graphic	LCD Graphic	60, upgradeable	Mains / Others	6 kg / 2 g - 15 kg / 5 g	7POSPT0LNE __

## Characteristics and functionality

### Main characteristics

- Weight only or price computing scale for checkout applications.
- Modular and modern design.
- Easy integration into counters.
- ECR / POS connection.
- Optional tempered glass plate. Customizable with client's logo.
- Valid for legal metrology.

### Features

- EAN heading programming (according to the communication protocol).
- Tare, fix tare and manual zero.
- Display of price in a secondary currency.
- Energy saving via programmable on and off back lighting switching and automatic disconnection.
- Power supply and communications through one single USB cable.

### Capacity / Accuracy

- Multirange (3,000 divisions): 6 kg / 2 g - 15 kg / 5 g.
- Optional:
  - › Monorange (3,000 divisions): 15 kg / 5 g.

### Available formats

- Flat.
- Pole.

### Construction

- **Structure:**
  - › ABS plastic casing.
- **Displays:**
  - › Easy to install in multiple positions 1 or 2 displays.
  - › Backlit LCD matrix graphic display.
  - › 5 digits (up to H20 mm) per display.
  - › Show only weight or weight, price/kg and total (connected to POS and depending on the communication protocol).
  - › Keypad with 3-keys.
  - › Stainless steel flat plate.

### Communication to PC / POS / ECR

- RS-232 interface.
- USB.
- Communication protocols available for the main POS and ECR in the market.
- Multi-protocols: the communication protocol is selected in the scale among the available ones. New protocols can be added from PC by telecharge (maximum: 60 protocols).

### Power supply

- Mains: 110/240 VAC through a USB cable with an AC/DC 5 V / 500 mA adapter.
- Others: through a USB cable (PC, etc.).

## Options

Option	Characteristics	Reference
Capacity 15 kg / 5 g	Monorange (3,000 divisions).	...N__ (*)
Metrological verification (M)	According to EU weighing directives. (See section on equipment metrological verification).	Consult

(\*) The scale references with this capacity are obtained by replacing the last characters of the reference for the standard scale with the indicated ending.

## Accessories



Ref: 494834A

### Buyer Display for the base

Matrix graphic display.



Ref: 494835A

### Buyer Display for the pole

Matrix graphic display.



Ref: 494839A

### Tempered glass plate (customizable)

Stainless steel plate also included.

Note:

- The references correspond to standard models: Black ABS plastic casing, backlit LCD segment display, flat stainless steel plate and RS-232 and USB communications. Capacity/Accuracy: 6 kg / 2 g - 15 kg / 2 g.