

DOSS
Bluetooth
Wireless Portable Bluetooth Speaker



Model No.: SoundBox Pro
User Manual

Introduction
Thank you for purchasing the DOSS SoundBox Pro, the true stereo wireless Bluetooth speaker. We advise you to read, follow and keep the following instructions in order to be able to correctly set up the speaker and enjoy all of its features to the fullest.

Packing content

- 1 x DOSS SoundBox Pro
- 1 x Micro USB charging cable
- 1 x 3.5mm auxiliary cable
- 1 x User manual

Specifications
Output: 20W x 2
Input: DC 5V / 1A
Battery: 1 x 18650 7.6V 2200mAh
Weight: 510g
Bluetooth Range: 20m/66ft
Unit dimension: 8.9 x 3.3 x 3.1 inches
Play time: 15hrs (50% volume without light and extra bass on)
Warranty: One year limited

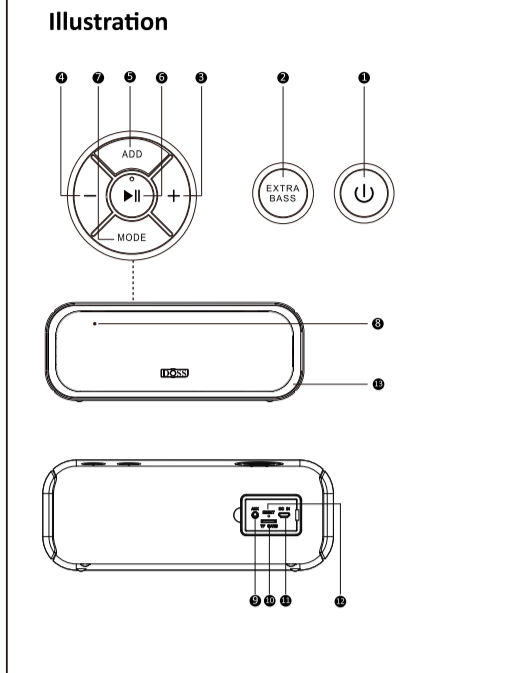

- Buttons and controls**
- | Buttons | How to use | Show to |
|-----------|------------|-------------------------------|
| Power | Press | Power on and hold for 30 secs |
| Bluetooth | Press | Bluetooth pairing |
| Volume | Press | Volume up/down |
| Light | Press | Light on/off |
| Micro USB | Press | Micro USB charging |
| 3.5mm | Press | 3.5mm audio input |
| Mode | Press | Mode (TWS, TF, etc.) |
| TF | Press | TF card slot |
| Light | Press | Light on/off |
| Volume | Press | Volume up/down |
| Bluetooth | Press | Bluetooth pairing |
| Power | Press | Power on and hold for 30 secs |

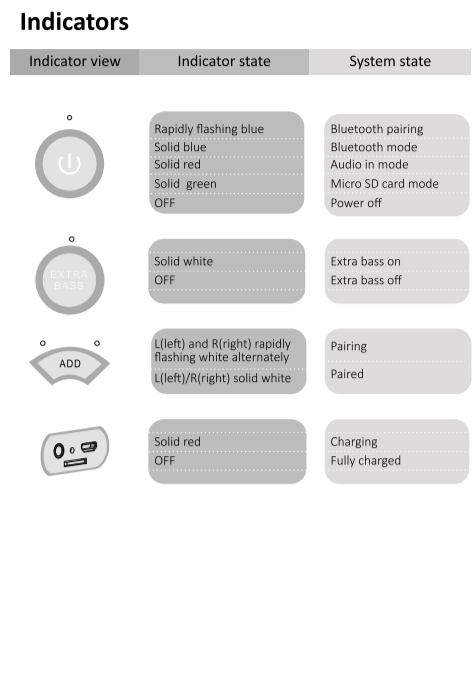

Preparation
To be able to use the speaker, you need to charge your portable speaker. From your computer, connect the Micro USB cable to the speaker and charge it for 1-2 hours. The charging indicator will turn red when charging and will turn blue when fully charged.

Note:

- If the speaker does not work, please check the battery level.
- The speaker has a built-in battery pack which will self-recharge when it is fully charged. If you have any questions, please contact support@dossaudio.com.

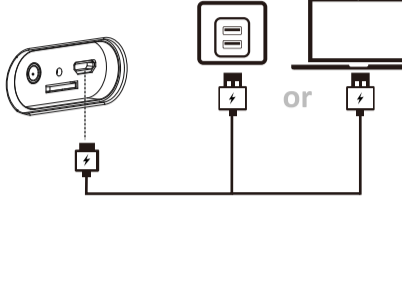

Operations

Turning On the speaker

- Press the power button. The Bluetooth indicator will glow blue after turning on.

Pair your speaker with your smart device via Bluetooth

Turn on Bluetooth on your phone and choose SoundBox Pro in the list. If the pairing is successful, your speaker will be paired.

Having problems connecting?

- Check the Bluetooth indicator.
- Check the Bluetooth pairing for your device.
- Reset the Bluetooth pairing.
- Check the Bluetooth indicator.
- Check the Bluetooth indicator.
- Check the Bluetooth indicator.

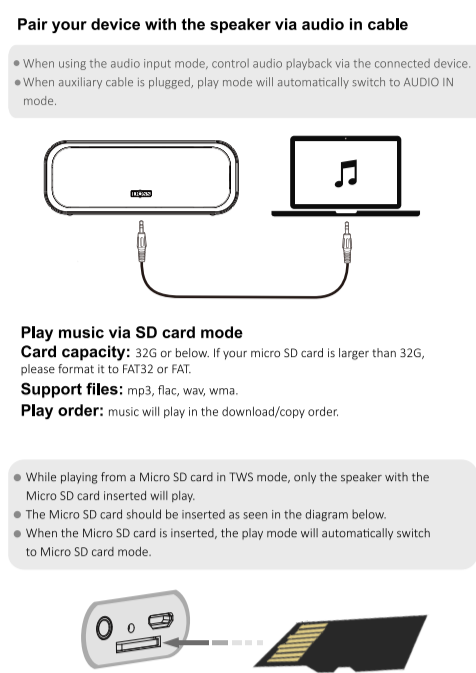

How to change the LED colors

There are three color "MODE" icons to get the single color mode.

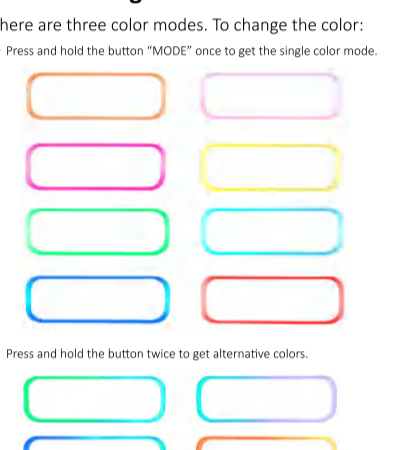

- Press and hold the button "MODE" icon to get the single color mode.
- Press and hold the button twice to get alternative colors.
- Press and hold the button three times to get different alternative colors.

How to set up true wireless stereo pairing

Start the first speaker:

- Turn on the speaker, press and hold the ADD button.

Start the second speaker:

- Turn on the speaker, press and hold the ADD button.

Note:

- The LED light (see 13) of the Bluetooth Pro first and second speakers will glow slowly flashing after pairing.
- Start the second speaker within 30 seconds, otherwise the TWS pairing mode of the speaker will be discontinued.
- While pairing, the secondary speaker will disconnect from the first device. Please press the secondary speaker and disconnect from the first device. After that, you can connect the first and second speakers to disconnect from the first device and start TWS pairing.
- If the TWS mode is activated when you are listening to music, press and hold the ADD button to return to TWS mode.
- TWS mode cannot be activated through Micro SD card mode.

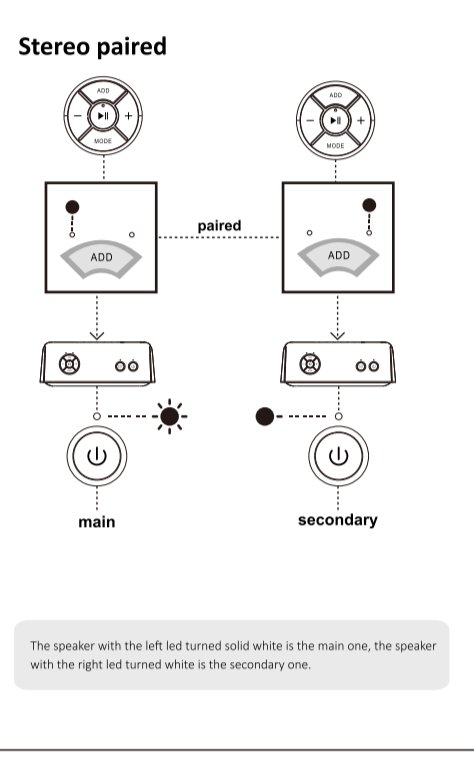

Use your speaker with Echo Dot

You are able to connect the Dot with SoundBox Pro via a 3.5mm aux cable or Bluetooth. Please follow the steps below to set up an Echo Dot connected to your SoundBox Pro.

- Download the app and follow the standard setup procedure to get the dot connected to your phone with an internet.
- Download the app and follow the standard setup procedure to get the dot connected to your phone with an internet.
- Download the app and follow the standard setup procedure to get the dot connected to your phone with an internet.
- Press the power button to turn on the speaker.
- Press the power button to turn on the speaker.
- Press the power button to turn on the speaker.

Note: When connecting the dot to the speaker, please contact our customer service at support@dossaudio.com.

Trouble shooting

Symptom	Solutions
No operation in speaker mode	<ul style="list-style-type: none"> Make sure the device is on and playing music. Remove the speaker from your speaker device. Turn on the device's property connected through the app. Restart the device. Restart the device. Restart the device.
No operation in speaker mode	<ul style="list-style-type: none"> Make sure the device is on and playing music. Remove the speaker from your speaker device. Turn on the device's property connected through the app. Restart the device. Restart the device. Restart the device.
No operation in speaker mode	<ul style="list-style-type: none"> Make sure the device is on and playing music. Remove the speaker from your speaker device. Turn on the device's property connected through the app. Restart the device. Restart the device. Restart the device.

Warning

- Do not use the speaker in an environment with high humidity or dust.
- Do not use the speaker in an environment with high humidity or dust.
- Do not use the speaker in an environment with high humidity or dust.
- Do not use the speaker in an environment with high humidity or dust.
- Do not use the speaker in an environment with high humidity or dust.
- Do not use the speaker in an environment with high humidity or dust.

Note

This equipment has been tested and found to comply with the limits for a Class B digital device, pursuant to part 15 of the FCC Rules. These limits are designed to provide reasonable protection against harmful interference in a residential environment. This equipment generates, uses and can radiate radio frequency energy and, if not properly installed and used, may cause interference with other electronic equipment. However, there is no guarantee of interference in all instances and in all locations.

If you experience any interference, you may wish to take the following steps:

- Reorient or relocate the receiving antenna.
- Increase the distance between the equipment and the receiver.
- Connect the equipment to a power outlet on a different circuit than the receiver.
- Consult the dealer or an experienced radio/TV technician for help.

The device must not be used to operate a motor vehicle while driving, while operating a machine, or while operating any other safety-sensitive function.

DOSS

For updates, promotions, and experience sharing, join our customer community.

- @dossfans
- @dossfans
- @dossdirect

www.dossaudio.com

support@dossiv.com

1-833-275-3677 Mon-Fri 9AM-5PM PST (USA)