

# PROheat™

USER'S GUIDE

# 2X

9200, 9400 SERIES 220-240V



**3 Safety Instructions**

**4-5 Product View**

**6 Assembly**

**7-11 Features/Operation**

**12-19 Maintenance and Care**

**19-20 Troubleshooting**

**21 Consumer Services**

**22-23 Replacement Parts**

**24 Warranty**



## Thanks for buying a BISSELL ProHeat 2X

We're glad you purchased a BISSELL ProHeat 2X heated formula deep cleaner. Everything we know about floor care went into the design and construction of this complete, high-tech home cleaning system.

Your ProHeat 2X is well made, and we back it with a limited two-year warranty. We also stand behind it with a knowledgeable, dedicated Consumer Services department, so, should you ever have a problem, you'll receive fast, considerate assistance.

My great-grandfather invented the floor sweeper in 1876. Today, BISSELL is a global leader in the design, manufacture, and service of high quality homecare products like your ProHeat 2X.

Thanks again, from all of us at BISSELL.

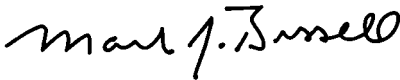

**Mark J. Bissell**  
**President and Chief Executive Officer**

# IMPORTANT SAFETY INSTRUCTIONS

When using an electrical appliance, basic precautions should be observed, including the following:

## READ ALL INSTRUCTIONS BEFORE USING YOUR UPRIGHT DEEP CLEANER.

Always connect to a properly Earthed outlet. Unplug from outlet when not in use and before conducting maintenance or troubleshooting.

 **WARNING:** To reduce the risk of fire, electric shock, or injury:

- Use indoors only
- Do not immerse
- Use only on surfaces moistened by cleaning process
- Do not leave machine when it is plugged in
- Do not service machine when it is plugged in
- If the supply cord is damaged, it must be replaced by the manufacturer or its service agent in order to avoid a hazard
- Do not use machine if it has been dropped, damaged, left outdoors or dropped into water
- Do not expose to rain, store indoors
- Do not pull or carry by cord, use cord as a handle, close door on cord, pull cord around sharp corners or edges, run appliance over cord, or expose cord to heated surfaces
- Do not carry the appliance while in use
- Do not unplug by pulling on cord; unplug by grasping plug not the cord
- Do not handle plug or appliance with wet hands
- Do not put any object into appliance openings, use with blocked opening or restrict air flow
- Do not expose hair, loose clothing, fingers or body parts to openings or moving parts
- Do not pick up hot or burning objects
- Do not pick up flammable or combustible materials (lighter fluid, petrol, kerosene, etc.) or use in the presence of explosive liquids or vapours
- Do not use appliance in an enclosed space filled with vapours given off by oil base paint, paint thinner, some moth proofing substances, flammable dust, or other explosive or toxic vapours

- Remove plug from electrical outlet before cleaning or maintaining the appliance
- Not intended for use by young children or infirm persons without supervision
- Young children should be supervised to ensure that they do not play with the appliance
- Do not pick up toxic material (chlorine bleach, ammonia, drain cleaner, petrol, etc.)
- Do not modify the Earthed plug
- Do not allow to be used as a toy
- Do not use for any purpose other than described in this User's Guide
- Use only manufacturer's recommended attachments
- Use only cleaning products formulated by BISSELL for use in this appliance to prevent internal component damage
- Keep openings free of dust, lint, hair, etc.
- Keep appliance on a level surface
- Turn off all controls before unplugging
- Be extra careful when cleaning stairs
- Pay close attention when working around children

## SAVE THESE INSTRUCTIONS.

THIS MODEL IS FOR HOUSEHOLD USE ONLY.

 **WARNING:** This appliance must be Earthed.

**IMPORTANT** FOR OPERATION ON A 220-240 VOLT A.C. 50/60 Hz POWER SUPPLY ONLY.

If your appliance is fitted with a nonrewireable BS 1363 plug it must not be used unless a 13 amp (ASTA approved to BS 1362) fuse is fitted in the carrier contained in the plug. Spares may be obtained from your BISSELL supplier. If for any reason the plug is cut off, it must be disposed of, as it is an electric shock hazard should it be inserted into a 13 amp socket.

# Product view

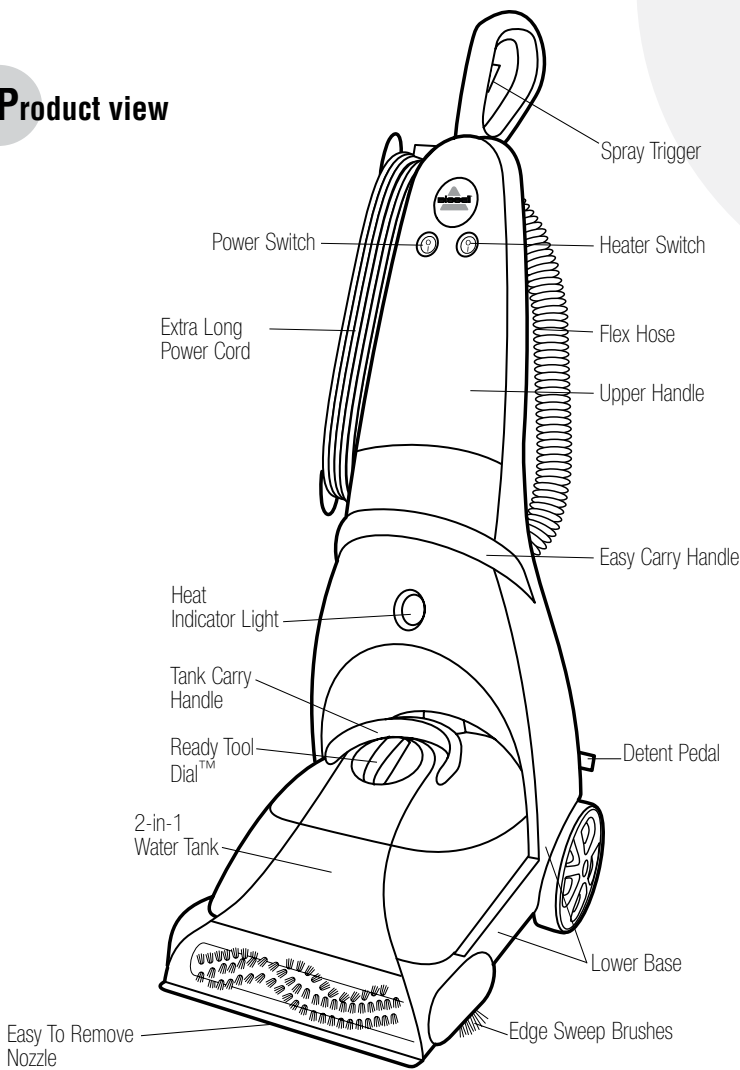

## Optional Accessories:

These items are available for purchase. To order replacement parts, additional tools or formulas, please refer to page 22-23.

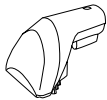

3" Tough Stain Brush



4" Upholstery Tool

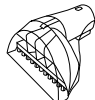

6" Stair Tool

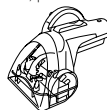

TurboBrush™

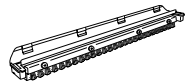

Hard Floor Attachment



Spraying Crevice Tool



Scotchgard™ Protector Applicator

# Product view

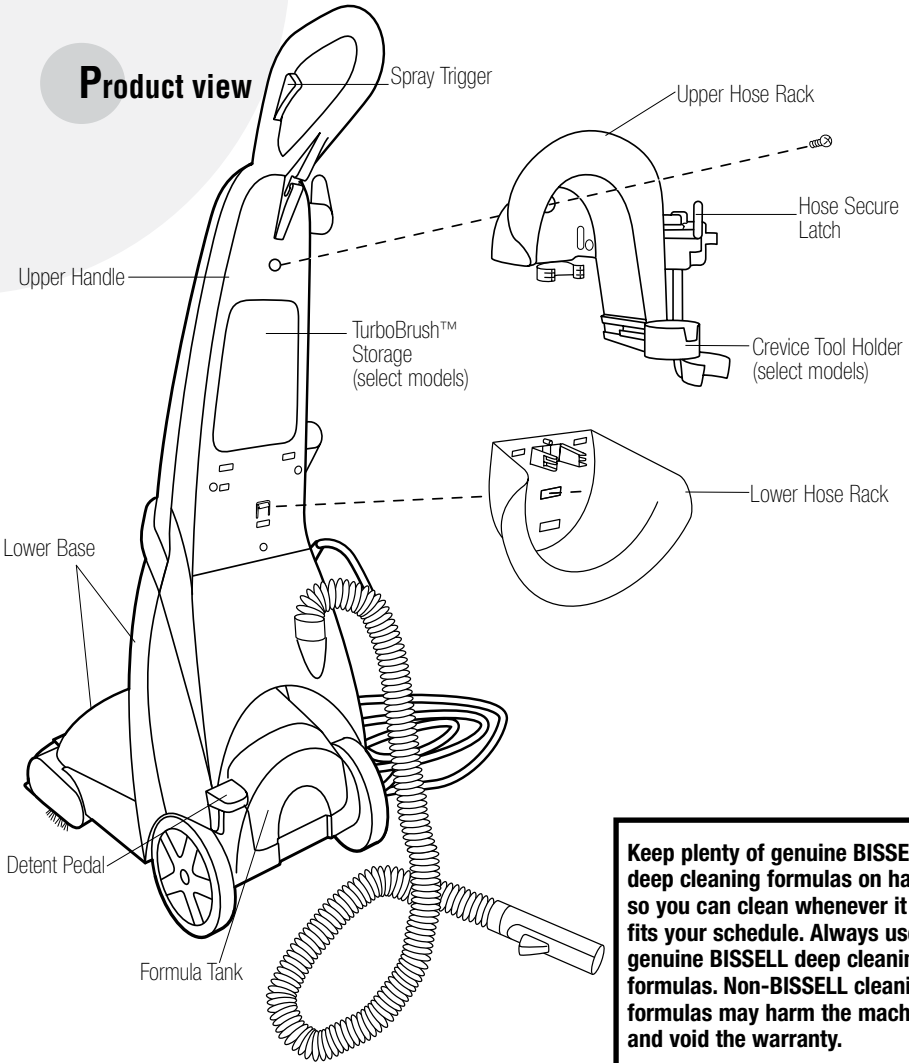

**Keep plenty of genuine BISSELL deep cleaning formulas on hand so you can clean whenever it fits your schedule. Always use genuine BISSELL deep cleaning formulas. Non-BISSELL cleaning formulas may harm the machine and void the warranty.**

## BISSELL Formulas:

These items are available for purchase. To order replacement parts, additional tools or formulas, please refer to page 22-23.



1.42 L  
Fibre Cleansing  
Formula™ with  
Scotchgard™  
protector



1.42 L  
Multi-Allergen  
Removal™ Formula  
with Scotchgard™  
protector



1.42 L  
Pet Odor and Soil  
Removal™ Formula  
with Scotchgard™  
protector



1.42 L  
Natural Orange  
Extract Formula with  
Scotchgard™  
protector



1.42 L  
Lavender Essence  
Formula with  
Scotchgard™  
protector



32 oz.  
Hard Floor  
Solutions™  
Formula



8 oz.  
Scotchgard  
Protector Post  
Treatment  
Cartridge



## How to put it together

This user's guide has been designed to help you get the most satisfaction from your BISSELL ProHeat 2X. You'll find assembly and operating instructions, safety precautions, as well as maintenance and troubleshooting instructions. Please read this user's guide thoroughly before assembling your deep cleaner.

Pay particular attention to the product diagram, assembly instructions, and part names. Locate and organize all parts before assembly. Familiarize yourself with the parts and where they go. Following this user's guide will greatly enhance your ability to get the most performance from your BISSELL ProHeat 2X for many years.

## Assembly

Your ProHeat 2X comes in three, easy to assemble components:

- Upper Handle
- Lower Handle
- Tool Caddy

The only thing you will need to assemble your cleaner is a Phillips head  screwdriver.

### Refer to Assembly Diagram on page 5

1. Slide upper handle onto lower handle.
2. Screw 3 screws into the marked holes.
3. Place upper hose rack onto back of upper handle and secure with tapered screw.
4. Place lower hose rack onto back of upper handle by pushing in and sliding down until it snaps into place.
5. Snap tools into the tool caddy as shown in figure 5.
6. Wrap power cord and flex hose as shown in figure 6.
7. Keep flex hose snugly in place by using the hose secure latch.

**ProHeat 2X assembly is now complete.**



## WARNING:

Do not plug in your cleaner until you have completely assembled it per the following instructions and are familiar with all instructions and operating procedures.

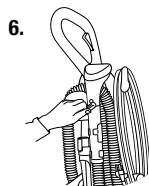
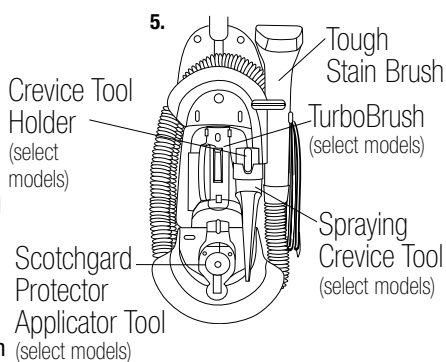
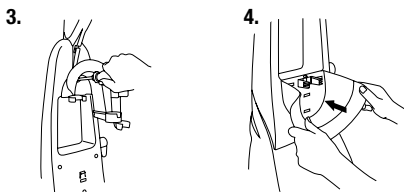
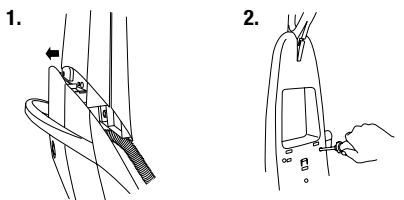

## Special Features

Your BISSELL ProHeat 2X deep cleaner is a home cleaning system that uses the power of heat, brushes and cleaning formula to get the deep down dirt for a maximum clean. Not only does it come with a lot of unique features, it has been designed with you, the customer, in mind.

### Built-in heater

BISSELL ProHeat models all feature a patented built-in heater which will heat the hand hot tap water you put in up to 25 degrees hotter to safely optimize cleaning effectiveness. The heater will never allow the temperature to exceed 190 degrees. The heater switch on the front of the machine controls the heater so you have the option to turn off the heat if you are cleaning delicate wool or oriental rugs.

### Dual DirtLifter PowerBrush

The two DirtLifter PowerBrush rolls are designed to enhance cleaning performance. The bristle pattern safely lifts out the deep down dirt while gently grooming carpet fibres. The floating suspension self-adjusts to all carpet heights and protects your carpet if you leave the power switch ON (I). Once the product is in the upright position, the brushes automatically stop spinning. The detent pedal will activate the brushes when floor cleaning.

### Custom Clean™

The Custom Clean feature automatically mixes hand hot tap water with the BISSELL formula. Simply choose one of the 4 settings (heavy traffic, normal clean, light clean, or rinse) and the ProHeat 2X will adjust the right amount of cleaning formula to mix with the heated water to fit your cleaning need.

This feature is available on all ProHeat 2X models, either behind the 2-in-1 water tank or on the upper handle.

Having a separate formula tank from the 2-in-1 water tank also allows no waste of formula. Because the water and formula are stored separately, they are not mixed until you are ready to clean. When your cleaning job is finished, the formula can be stored ready to use in your machine for the next time!

(located behind 2-in-1 water tank)

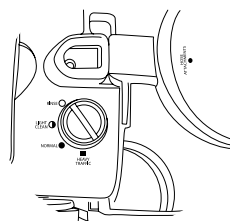

OR

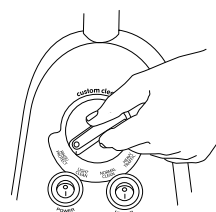

(located on upper handle)

## Special Features

### Scotchgard Protector Applicator Tool and Scotchgard Warranty

Carpet protection applied at the mill typically wears down with heavy foot traffic over time and with everyday cleaning, including deep cleaning. To help restore this important protection, BISSELL offers deep cleaning formulas with Scotchgard protector and a post-applicator to apply Scotchgard protector with the same materials used by carpet mills. This offers extra protection against dirt and tough stains to keep your carpets looking good longer.

To maintain your Scotchgard 5-year limited stain warranty, you no longer are required to hire a professional cleaner. By using your BISSELL ProHeat machine with BISSELL Formulas containing Scotchgard protector every 12 months, your carpet warranty from 3M remains in effect. No other home deep cleaning system can do this for you. Refer to the Scotchgard protector warranty for details.

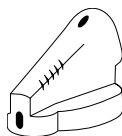

### 2-in-1 water tank

Our 2-in-1 water tank full capacity system is designed with a heavy duty bladder inside for clean water. As you clean, the clean water in the bladder will empty and mix with the cleaning formula. Dirty water pulled out of your carpets will collect around the outside of the bladder so that clean and dirty water are always kept separate. This allows the user to maximize tank space, yet only carry one tank to and from the sink for emptying and filling.



### Easy to remove and clean nozzle

Now, cleaning up your machine after the cleaning process is easier than ever! Simply remove the 2-in-1 water tank and remove the screw to pop out the nozzle for rinsing in the sink. Dirt, loose carpet fibres and remaining pet hair or fuzz gets washed away in a snap.

### Ready tools dial

Now, cleaning up your machine after the cleaning process is easier than ever! Simply remove the 2-in-1 water tank and remove the screw to pop out the nozzle for rinsing in the sink. Dirt, loose carpet fibres and remaining pet hair or fuzz gets washed away in a snap.

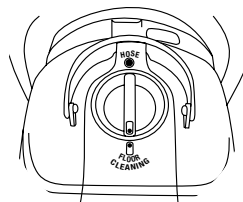



# Operation

## Before you clean carpets

1. Plan activities to give your carpet time to dry.
2. Move furniture to another area if cleaning an entire room (optional).
3. Vacuum area with a dry vacuum cleaner thoroughly before deep cleaning.
4. Plan your cleaning route to leave an exit path. It is best to begin cleaning in the corner farthest from your exit.

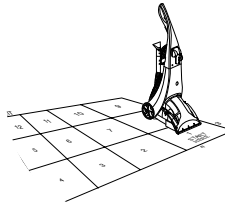

## Carpet cleaning

1. **Fill the 2-in-1 water tank.** Remove the tank from the base of the machine by lifting up the tank carry handle. Carry like a bucket to the sink.

- 1a. Unlatch the top of the tank from the bottom by lifting up on the tank latch which is located on the back of the tank.

- 1b. Remove the top of the tank by lifting up on the handle.

**Note how the lip on the top tank separates from the groove in the bottom tank. This placement is important when putting the tank back together.**

- 1c. Fill the heavy duty bladder with clean hand hot tap water.

**\*Do not boil or microwave water as it can destroy the bladder.**

- 1d. Leaving the filled bottom of the tank on a flat surface, only maneuver the top of the tank. To attach the top part of the tank to the bottom, carefully hook the lip on the top tank into the groove on the bottom tank.

- 1e. Fasten tanks together by securing the latch in the back.

**Note: Remember to secure the tank latch in the back and test to make sure it is secure before picking up the tank.**

**ATTENTION:**  
Some Berber carpets have a tendency to fuzz with wear. Repeated strokes in the same area with an ordinary vacuum or deep cleaner may aggravate this condition. Please see Stain Removal instructions on page 16.

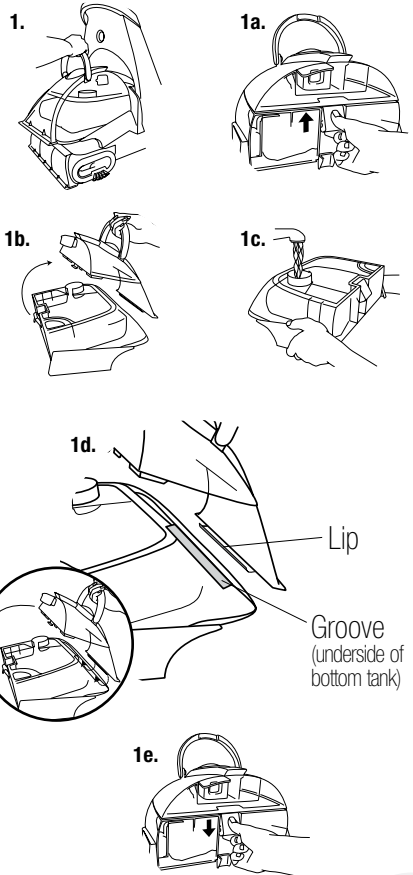

# Operation

## Carpet cleaning continued

- 2. Fill the formula tank.** Fill up the formula tank by first unscrewing the cap and insert. Always use genuine BISSELL formulas to maximize cleaning and for the safety of your machine. Fill formula up to the line and replace the cap and insert. Place formula tank into the slot in the back of the machine for a snug fit.
- 3. Set Custom Clean dial.** Simply choose one of the 4 settings (heavy traffic, normal clean, light clean, or rinse) and the ProHeat 2X will adjust the right amount of cleaning formula to mix with the heated water to fit your cleaning need.
- 4. Set Ready Tools dial to the floor cleaning setting.**
- 5. Plug into a proper outlet and turn the power and heater switches to the ON (I) position.** Allow one minute for the built-in heater to warm-up before cleaning. The ProHeat 2X will be fully warmed and will provide optimal performance after one minute of continuous heated cleaning.
- 6. Cleaning strokes.** While pressing the spray trigger, make one slow forward wet pass and another one back. Let the built-in heater, formula, and DirtLifter PowerBrushes do the work for you. **Caution: Do not overwet.** Take care not to run over loose objects or edges of area rugs. Stalling the brush may result in premature belt failure.

**Note: Your machine is equipped with a circuit breaker that will automatically shut off the brush if a large or loose object is caught in the brush roll. If that happens, be sure to unplug your machine, remove the foreign object, and then plug the machine back in to reset the circuit breaker.**

Release the spray trigger and make one slow forward and backward pass over the same area to remove any residual dirty water and aid in drying. Repeat cleaning passes until water being pulled up appears clean. Continue passes without pressing the spray trigger until you can't see any more water being pulled up. After cleaning, you may want to turn the Custom Clean dial to rinse to give your carpeting a final water only rinse. This will ensure thorough removal of embedded dirt loosened by the formula. BISSELL deep cleaning formulas contain an anti-resoiling agent that helps your carpets repel dirt and keeps them looking good longer.

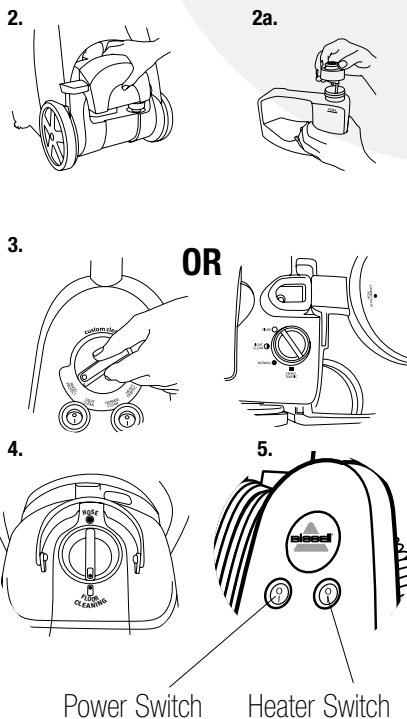

### WARNING:

To reduce the risk of fire and electric shock due to internal component damage, use only BISSELL deep cleaning formulas intended for use with the deep cleaner.

Keep plenty of genuine BISSELL deep cleaning formula and Scotchgard™ protector cartridges on hand so you can clean and protect whenever it fits your schedule. Always use genuine BISSELL deep cleaning formulas. Non-BISSELL cleaning formulas may harm the machine and void the warranty.

# Operation

## Carpet cleaning continued

7. Remove the tank from the base of the machine by lifting up on the tank carry handle. Carry like a bucket to a utility sink or outside where you will dispose of the dirty water.

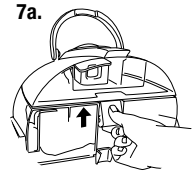

7a. Unlatch the top of the tank from the bottom by lifting up on the tank latch which is located on the back of the tank.

7b. Remove the top of the tank by lifting up on the handle.

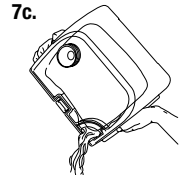

**Note** how the lip on the top tank separates from the groove in the bottom tank. This placement is important when putting the tank back together.

7c. Lift the bottom portion of the tank and pour out dirty water toward the sink through the triangular shaped opening in the corner of the tank.

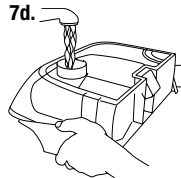

**Note:** You may notice hair & debris deposits on the carpet or in the tank that were loosened by the cleaning action (especially with newer carpets that have never been deep cleaned before). This debris should be picked up and thrown away.

7d. Fill the heavy duty bladder with clean hand hot tap water, following instructions page 9.

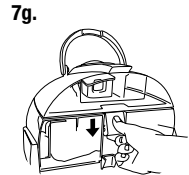
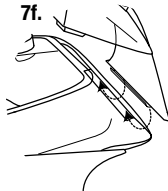

**Note:** Remember to secure the tank latch in the back and test to make sure it is secure before picking up the tank. Always check the level of cleaning formula in the formula tank at the same time and refill as needed.

8. **Rinse (Optional).** Rinsing is an optional step that can be done during the cleaning process by switching from one of the clean settings on the Custom Clean dial to a rinse setting, or it can be done after the carpeted area has been cleaned. Simply choose the rinse setting on the Custom Clean dial, and follow the same path as you did for cleaning, taking care to do a forward (wet) stroke by depressing the spray trigger, a backward (wet) stroke, and a forward and backward (dry) stroke, releasing the spray trigger. Continue this until the water you see coming up the nozzle is clear.

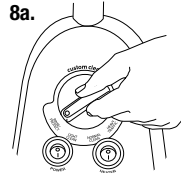

or

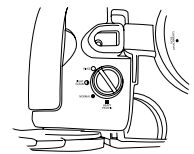

## Maintenance and care



### Machine storage

Once your cleaning is complete, make sure the 2-in-1 water tank is emptied, rinsed out, and dried before the next use. The formula tank can remain filled and ready to go, or it can simply be emptied back into the formula bottle if that is more convenient.

**Note:** Store cleaner in a protected, dry area. Since this product uses water, it must not be stored where there is a danger of freezing. Freezing will damage internal components and void the warranty.

### Machine care

For best results, a few simple steps can assure your machine is well maintained after your cleaning is complete.

1. Turn power and heater switches OFF (O). Unplug the machine and wrap the power cord.
2. After emptying the 2-in-1 water tank, rinse it out at a faucet with running hand hot tap water, taking care to clean underneath the heavy duty bladder and all around it.
3. The top half of the tank can be rinsed clean through the nozzle area. Also, pop out the red filter underneath the top half of the tank and rinse that out. Replace before putting the top and bottom halves of the tank together.
4. Before you place the cleaned 2-in-1 water tank back onto the machine, simply unscrew the nozzle using a Phillips head screwdriver . This can be rinsed out at the faucet. Then replace back onto the machine by starting from the bottom of the nozzle and hooking the tabs into the holes on the bottom sides of the machine. Secure into place with the screw.
5. The inside of the end caps by the brush rolls can be wiped out with a clean paper towel, or, if a more thorough cleaning is desired, the end caps can be taken off using a Phillips head  screwdriver and rinsed clean. Replace after cleaning.
6. Any loose hair or debris can be pulled from the brush rolls and thrown away. For the most thorough clean before storage, follow directions on pages 18 & 19 for removal and replacement of the brush rolls and belts.



### WARNING:

To reduce the risk of fire, electric shock or injury, unplug from the outlet before servicing.

3.

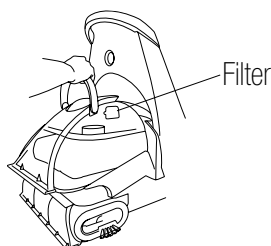

### Tip:

Let all parts dry completely before storing



### WARNING:

To reduce the risk of fire, electric shock or injury, unplug from the outlet before servicing.

# Maintenance and care

## Machine care continued

7. To clean attachments that may have been used, remove from hose and rinse in clean, running water. Dry and replace attachment in the tool caddy. Clean the flex hose by suctioning clean water from the tap. Before replacing, lift end of flex hose and stretch out to ensure all water is cleared from flex hose. Refer to page 15, illustrations 9 & 10.
8. After carpet is dry, vacuum again to remove hair and fuzz.

## Post-treatment Scotchgard Protector\* (optional)

Some models are equipped with a Scotchgard protector post-treatment applicator and cartridge. Using this, along with one of the BISSELL deep cleaning formulas containing Scotchgard, to help retain the carpet cleanliness achieved with the ProHeat 2X machine. For best results, the post cleaning treatment should be applied while the carpet is still damp. It is recommended that the Scotchgard protector be applied every 12 months to all clean carpeted areas, and after every deep cleaning for high traffic areas such as entryways and stairs.

1. Immediately after cleaning and rinsing your carpets, empty the 2-in-1 water tank and refill the heavy duty bladder with clean hand hot tap water.
2. Set Ready Tools dial to the hose/attachment setting.
3. Purge the hose to eliminate cleaning formula from the tube by spraying clean water through the flex hose (without attachments) into a sink for 15-30 seconds.
4. Attach Scotchgard protector post-treatment cartridge to the applicator tool, following the instructions on the cartridge. Attach the combined tool/cartridge to the flex hose. The water from the 2-in-1 water tank will automatically mix with the concentrated Scotchgard protector post-treatment formula contained in the cartridge.
5. Turn the Custom Clean dial to the rinse/protect setting.
6. Before applying Scotchgard protector to a large area, test in a small, hidden area for colourfastness. Examine area when dry. If colour is affected, do not use. For use on upholstery, look for manufacturer's cleanability code tag. Use only on fabrics coded "W" or "WS". If coded "S" or "X", do not use. Not recommended for use on velvet, silk vinyl, leather, or 100% cotton upholstery.

3.

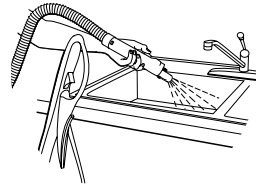

4.

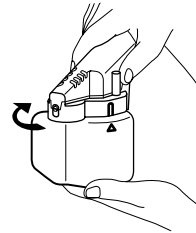

### Tip:

If clogged, soak applicator tool in hand hot tap water before using.

# Maintenance and care

## Post-treatment Scotchgard Protector\* (optional) continued

7. Apply Scotchgard protector in a slow sweeping motion with a slight overlap of the treated area. For best coverage, follow the guide on the cartridge.
8. One 8 oz. cartridge protects 200 square feet (18.6 sq. meters). This is equal to two average size rooms, (each at 10 x 10 ft. or 3 x 3 meters). Periodically check the level in the bottle to ensure the best coverage.
9. Be careful not to spray the Scotchgard protector onto furniture or fabric that has not been tested for colourfastness. If this does occur, wipe off the Scotchgard protector.
10. When finished remove the cartridge from the applicator tool. If formula is left, replace the cap to the cartridge and store at room temperature for later use.
11. With the applicator tool still on the end of the flex hose, spray clean hand hot tap water into the sink to avoid any future clogging. Let dry before storing.
12. Store applicator tool in a convenient location for use the next time.

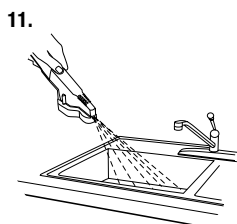
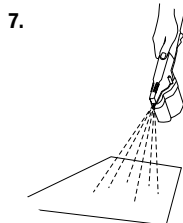

## Cleaning with attachments

Your ProHeat 2X machine comes equipped with a flex hose and at least one cleaning tool for cleaning stairs, upholstery, and more.

1. **Important!** If using to clean upholstery, check upholstery tags.
  - a. Check manufacturer's tag before cleaning. "W" or "WS" on the tag means you can use your ProHeat 2X. If the tag is coded with an "X" or an "S" (with a diagonal stripe through it), or says "Dry Clean Only", do not proceed with any deep cleaning machine. Do not use on Velvet or Silk. If manufacturer's tag is missing or not coded, check with your furniture dealer.
  - b. Check for colourfastness in an inconspicuous place.
  - c. If possible, check upholstery stuffing. Coloured stuffing may bleed through fabric when wet.
  - d. Plan activities to allow upholstery time to dry.
  - e. Vacuum thoroughly to pick up loose debris and pet hair. Use a vacuum with a brush attachment and a crevice tool to clean in fabric folds.

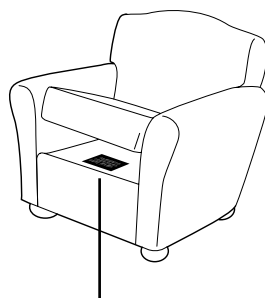

Manufacturer's tag



**WARNING:**  
To reduce the risk of injury, be extra careful when cleaning stairs. Make sure machine is secure and level.

# Maintenance and care

## Cleaning with attachments continued

- Follow the instructions on pages 9 & 10 for filling the 2-in-1 water tank and the formula tank.
- Set Ready Tools dial to the hose attachments setting. This will allow spray and suction from the flex hose.
- Set Custom Clean dial for heavy traffic, normal clean, light clean, or rinse, as desired
- Attach the cleaning tool to the end of the hose.
- Plug in and turn on the power switch.
- Note: The built-in heater heats the cleaning formula for carpet and hard floor application only. It does not heat the cleaning formula through the accessory tools.**
- Clean by pressing the spray trigger to spray formula onto the area to be cleaned. Slowly move the tool back and forth over the soiled surface. Release the spray trigger to suction soiled water. Continue to clean in the area, working in small sections, until no more dirt can be removed. Rinse (optional) and suction as needed. **Caution: Do no overwet.**
- Remove and rinse tools in clean, running water. Dry and replace in the tool caddy.
- It is recommended that you suction clean water from the tap to rinse out the flex hose.
- Before replacing, lift end of flex hose and stretch out to ensure all water is cleared from flex hose.
- Coil flex hose around the tool caddy.
- Empty 2-in-1 water tank and rinse out, following the instructions on page 11.
- Return Ready Tools dial to floor setting.

## Cleaning formula section

Keep plenty of genuine BISSELL advanced deep cleaning formula for full size machines on hand so you can clean and protect whenever it fits your schedule. Always use genuine BISSELL deep cleaning formulas.

5.

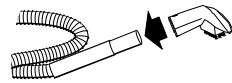

9.

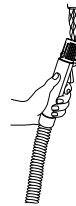

10.

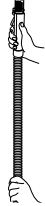

## WARNING:

To reduce the risk of fire and electric Shock due to internal component damage, use only BISSELL deep cleaning formulas intended for use with the deep cleaner. Non-BISSELL cleaning solutions may harm the machine and void the warranty.



1.42 L  
Fibre Cleansing  
Formula™ with  
Scotchgard™  
protector



1.42 L  
Multi- Allergen  
Removal™ Formula  
with Scotchgard™  
protector



1.42 L  
Pet Odor and Soil  
Removal™ Formula  
with Scotchgard™  
protector



1.42 L  
Natural Orange  
Extract Formula with  
Scotchgard™ protector



1.42 L  
Lavender Essence  
Formula with  
Scotchgard™  
protector



32 oz.  
Hard Floor  
Solutions™  
Formula



8 oz.  
Scotchgard  
Protector Post  
Treatment  
Cartridge

# Maintenance and care

## Stain removal

**Do not delay! Attending to an accident soon after it occurs ensures the most optimal clean. Leaving it for an extended period of time may cause it to set and become permanent.**

1. Blot up liquids with an absorbent cloth or paper towels. White materials are recommended because certain dyes may bleed and make the stain worse.
2. Gently scrape up any semi-solids with a spoon or spatula. Do not use a knife or other utensil with sharp edges because it could damage the carpet or upholstery.
3. If the area has dried, remove the remaining semi-solids and residue with a sweeper or vacuum.
4. Be sure to test any spot removal formulas in an inconspicuous area first. This is important as some dyes and materials could be damaged or discoloured by cleaning formulas. If such a change should occur, try a different formula or call a professional.
5. Use your Proheat 2X as a pre-cleaner. With one of the tools attached to the flex hose, set the Ready Tools dial to the hose attachments setting and the Ready Tools dial to heavy traffic. Spray the area with cleaning formula and allow the BISSELL Deep Cleaning Formula to penetrate 3-5 minutes.  
**Note: If cleaning on Berber carpeting, gently run your machine over a hidden area. If no fuzzing occurs, continue cleaning in soiled area.**
6. Once the pre-cleaning is complete, use the attached tool to gently scrub the stain with back and forth strokes.
7. Allow time to dry. Some difficult stains may require a second treatment.



## **WARNING:**

To reduce the risk of fire and electric shock due to internal component damage, use only BISSELL deep cleaning formula intended for use with the deep cleaner. Non-BISSELL cleaning formula may harm the machine and void the warranty.



# Maintenance and care

## Hard floor cleaning

Your ProHeat 2X model may come with a hard floor tool and Hard Floor Solutions formula. If not, these products are available for purchase by contacting the BISSELL Consumer Services department by phone. The hard floor tool provides effective cleaning for linoleum, vinyl, and tile floors.

**Caution: Do not use on unsealed hardwood floors.**

1. Vacuum or sweep thoroughly to pick up any loose debris and pet hair.
2. Move any furniture, if needed.
3. Empty any carpet cleaning formula back into the BISSELL bottle if stored in the formula tank. Fill formula tank with BISSELL Hard Floor Solution Formula.
4. Fill the 2-in-1 water tank with hand hot tap water and set aside.
5. Attach the hard floor tool onto the bottom of the machine by hooking it into the nozzle and swinging it down until it clicks into place.
6. Check Ready Tools dial. It should be set on floor cleaning.
7. Set the Custom Clean dial to normal clean.
8. Plug in and turn on the power switch and heater switch.
9. Slowly move the machine forward and back over bare floor surface one time while depressing spray trigger.  
**Caution: Do not overwet.**
10. Repeat the motion without pressing the spray trigger using the hard floor tool to squeegee and suction up the dirty water.
11. Allow adequate time for floors to dry.
12. Remove hard floor tool, rinse and dry before storing.
13. If any formula remains in the formula tank, pour it back into the Hard Floor Solutions bottle for use the next time.
14. Rinse out the formula tank.



## **WARNING:**

To reduce the risk of fire, electric shock or injury unplug from outlet before servicing.

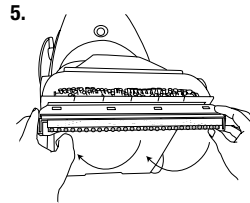

# Maintenance and care

## Small belt removal and replacement instructions

Occasional replacement of one or both belts may become necessary. If that is needed, please follow the instructions below.

1. Turn off the machine, and unplug it from the outlet.
2. Remove both the 2-in-1 water tank and the formula tank. Set aside.
3. Unscrew the nozzle and remove it. Set aside.
4. Turn the machine on its side. **IMPORTANT: Make sure that the cord side is down.**
5. Remove the clear end cap by unscrewing the 2 black screws. Take care not to drop the screws into the unit.
6. Remove 1 silver screw.
7. Remove pivot arm by gently lifting up.
8. Remove small brush belt.
9. Replace small brush belt, and reverse steps above.



### WARNING:

To reduce the risk of fire, electric shock or injury, unplug from the outlet before servicing.

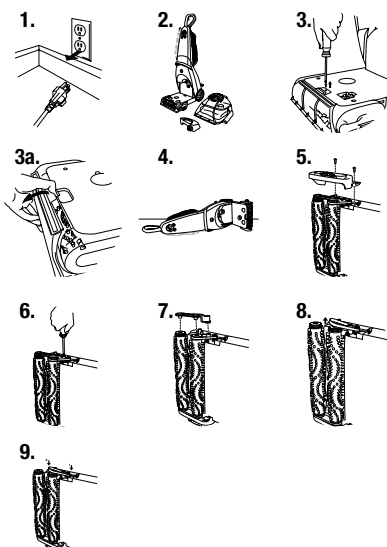

## Brush removal and large belt replacement instructions

Brushes can be removed for cleaning or replacement as needed.

1. Follow small belt removal instructions above.
2. Remove brush rolls by pulling them off of the metal rods.
3. Place cleaned or new brush rolls back onto the rods. Make sure one washer is on each end of the rollers prior to sliding onto the rod. Be sure to let the rod slide through the bushing to insure proper fit.
4. Re-attach the long belt on the bottom to the cogs of the small roller brushes.
5. Place small belt over back roller and metal cog.
6. Place pivot arm in place and screw in place using the silver screw.



### WARNING:

To reduce the risk of fire, electric shock or injury, unplug from the outlet before servicing.

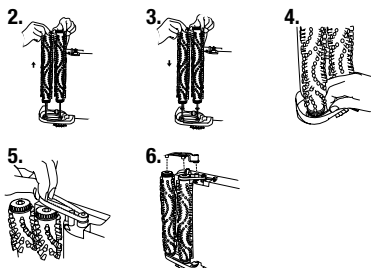

# Maintenance and care

## Brush removal and large belt replacement instructions

7. Re-attach clear end cap by tightening with the (2) black screws.
8. Return nozzle to front of unit, by latching from underneath and then securing with a screw.

If you have any questions or are having trouble installing or replacing your belt(s) or brushes, please call BISSELL Consumer Services in the UK at 0870.225.0109, in Australia at 1.800.811.183 or in New Zealand at 0800.247.735. For all other countries call our U.S.A. Headquarters at 616.453.4451 or visit the BISSELL Website: [www.bissell.com](http://www.bissell.com)

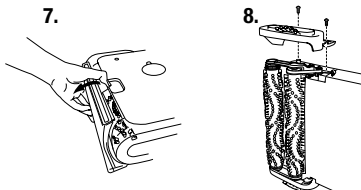

## Troubleshooting

### Built-in heater ready light does not illuminate

#### Possible Cause

1. The heater switch is not turned **ON (I)**
2. The power switch is not turned **ON (I)**

#### Remedies

1. Turn the heater switch **ON (I)**
2. Both switches must be **ON (I)** to activate the heater ready light

### Reduced spray or no spray

#### Possible Cause

1. 2-in-1 water tank may be empty
2. Formula tank may be empty
3. 2-in-1 water tank may not be seated completely
4. Pump may have lost prime

#### Remedies

1. Fill heavy duty bladder with hand hot tap water
2. Fill formula tank with BISSELL deep cleaning formula
3. Turn power switch **OFF (O)** remove and reseat 2-in-1 water tank
4. Turn power switch **OFF (O)** and then back **ON (I)**. Wait one minute, then depress spray trigger

### DirtLifter PowerBrushes do not turn

#### Possible Cause

1. The brush is off or broken
2. The unit is in the upright position
3. Circuit breaker may have tripped

#### Remedies

1. Turn power switch **OFF (O)** and unplug unit from outlet. Follow instructions on pages 18 and 19
2. Brushes only rotate when unit is reclined using the detent pedal
3. Turn the power switch **OFF (O)** and unplug from outlet. Check to see if foreign object is caught in brush roll. remove object. Plug machine back in to reset circuit breaker



## WARNING:

To reduce the risk of fire, electric shock, or injury, unplug machine from outlet before servicing.

# Troubleshooting

## Scotchgard protector applicator tool is not spraying

### Possible Cause

1. Cartridge is not connected to the tool
2. Ready Tools dial on floor setting
3. Formula clogging the spray trigger

### Remedies

1. Follow instructions on cartridge to assure proper fit
2. Set Ready Tools dial to hose attachments setting
3. Soak applicator tool only in hand hot water. Spray without the cartridge attached to purge any residual formula left in the applicator tool

## Cleaner not picking up solution

### Possible Causes

1. Ready Tools dial may be at wrong setting
2. 2-in-1 water tank may not be seated properly
3. 2-in-1 water tank may not be assembled properly
4. Formula or 2-in-1 water tank is empty
5. 2-in-1 water tank has picked up maximum dirty water and red float door has closed
6. Red float "door" in the tank may have closed as a result of bumping an object or moving machine back and forth too quickly

### Remedies

1. Set Ready Tools dial to either floor cleaning or hose attachments setting
2. Pick up both the 2-in-1 water tank and formula tank and reseal them so they fit snugly on the unit
3. Check to make sure the "lip" of the nozzle is securely hooked into the groove on bottom of 2-in-1 water tank (see page 9)
4. Check water levels in heavy duty bladder and formula tank
5. Empty 2-in-1 water tank. Refill heavy duty bladder with clean hand hot tap water and replace
6. Turn the machine **OFF (O)**, allowing red float door to release into the open position. Turn unit back **ON (I)** to continue cleaning. Be sure your forward and backward strokes are done at a slower pace

**Other maintenance or service not included in the manual should be performed by an authorized service representative.**

**Thank you for selecting a BISSELL product.**

**Please do not return this product to the store.**

# BISSELL Consumer Services

## If your BISSELL product should require service:

In the UK, Australia or New Zealand, call BISSELL Consumer Services at the numbers below and we will give you the location of a BISSELL Authorized Service Center in your area. For all other countries, contact your local in country distributor for questions, service, or repair.

If you have questions about your warranty or need replacement parts please contact the numbers below.

### For UK inquiries:

Monday - Thursday 9 am — 5 pm  
Friday 9 am — 4 pm

### BISSELL Homecare (Overseas) Inc.

The Boat Yard  
105 Straight Road  
Old Windsor  
Berkshire, SL4 2SE  
United Kingdom  
Telephone: 0870-225-0109

### For New Zealand inquiries:

Monday - Friday 9 am — 5 pm

### Parex Industries Ltd.

103 Central Park Drive  
Henderson  
Auckland  
New Zealand  
Telephone: 0800-247-735

Or visit the BISSELL website - [www.bissell.com](http://www.bissell.com)

When contacting BISSELL, have model number of unit available.

Please record your Model Number: \_\_\_\_\_

Please record your Purchase Date: \_\_\_\_\_

**Note: Please keep your original sales receipt. It provides proof of date of purchase in the event of a warranty claim. See Warranty on page 24 for details.**

Please do not return this product to the store.

### For Australian inquiries:

Monday - Friday 9 am — 5 pm

### BISSELL AUSTRALIA PTY LIMITED

Unit 35  
15 Ricketts Road  
Mount Waverley, Victoria 3149  
Australia  
Telephone: 1-800-811-183

### For all other inquiries:

Monday - Friday 8 am — 4 pm

### BISSELL Homecare, Inc.

PO Box 1888  
Grand Rapids, MI 49501 USA  
Telephone: 01-616-453-4451  
Fax: 01-616-453-1383

## Replacement parts BISSELL ProHeat 2X

Below is a list of common replacement parts. While not all of these parts may have come with your specific machine, all are available to you for purchase, if desired.

Item	Part No.	Part Name
1	203-6651	3" Tough Stain Tool
2	203-6652	Powered TurboBrush Hand Tool
3	203-6653	4" Upholstery Tool
4	203-6654	6" Wide Stair Tool
5	203-6655	Spraying Crevice Tool
6	203-6692	Hard Floor Tool
7	203-6691	Scotchgard Applicator Tool
8	203-6611	Grey Tank Assembly (complete) for Black unit (Blue or Purple complete tank assemblies available upon request)
9	203-6660	Grey Tank Lid (Blue or Purple Tank Lids available upon request)
10	203-6618	Grey Tank Bottom (Blue or Purple Tank Bottoms available upon request)
11	203-6601	Hose Assembly
12	203-6675	Cap and Insert for Water Tank
13	203-6676	Formula Tank (includes Cap & Insert for Formula Tank)
14	203-6677	Cap and Insert for Formula Tank
15	203-6678	Front Nozzle (includes gasket)
16	203-6679	Autoload Gasket (fits both Water and Formula Tank)
17	203-6680	Filter with Door
18	203-6681	Water Tank Latch
19	203-6682	Cord Wrap (Black) (Blue or Purple cord wrap available upon request)
20	203-6685	Clear End Cap w/Edge Brushes (2 pack, includes screws)
21	203-6686	Brush Roll – 6 row (includes 1 brush, axle, 2 swivel arms)
22	203-6688	Small Brush Belt (non-cord side)
23	203-6804	Large Brush Belt (cord side)
24	203-6689	Hose Secure Latch
25	203-6690	Hose Rack Assembly (Top/Bottom Hose Rack, Screws)
26	710E	1.42 L Fiber Cleansing Formula™ with Scotchgard™ protector
27	720E	1.42 L Multi-Allergen Removal™ Formula with Scotchgard™ protector
28	730E	1.42 L Pet Odor and Soil Removal™ Formula with Scotchgard™ protector
29	740E	1.42 L Natural Orange Extract Formula™ with Scotchgard™ Protector
30	750E	1.42 L Lavender Essence Formula™ with Scotchgard™ protector
31	0484	32 oz. Hard Floor Solutions™
32	0464	Scotchgard Protector Post Treatment Cartridge

**\*Not all parts are included with every model.**

# Replacement parts BISSELL ProHeat 2X

1

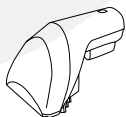

2

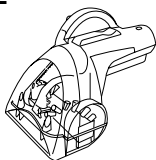

3

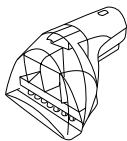

4

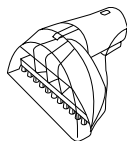

5

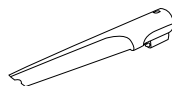

6

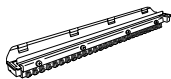

7

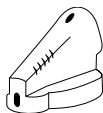

8

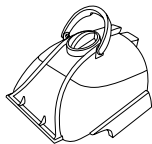

9

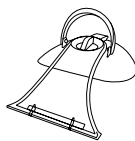

10

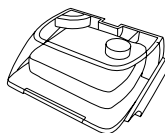

11

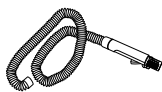

12

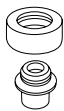

13

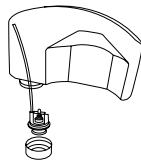

14



15

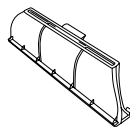

16

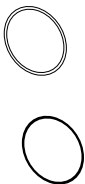

17

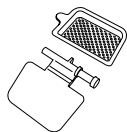

18

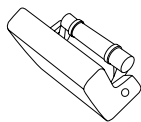

19



20



21

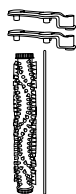

22



23



24



25

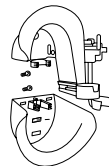

26



27



28



29



30



31



32



## Warranty - BISSELL ProHeat 2X

This warranty gives you specific legal rights, and you may also have other rights which may vary from country to country. If you need additional instruction regarding this warranty or have questions regarding what it may cover, please contact BISSELL Consumer Services by telephone, or regular post as described below, or contact your local in country distributor.

### Limited Two Year Warranty

Subject to the \*EXCEPTIONS AND EXCLUSIONS identified below, BISSELL Homecare, Inc., will replace (with new or remanufactured components), at BISSELL's option, free of charge from the date of purchase by the original purchaser, for two years any defective or malfunctioning part do to manufacturers defect.

This warranty applies to product used for personal, and not commercial or rental service. This warranty does not apply to fans or routine maintenance components such as filters, belts, or brushes. Damage or malfunction caused by negligence, abuse, or use not in accordance with the User's Guide is not covered.

#### For UK inquiries:

Monday - Thursday 9 am — 5 pm  
Friday 9 am — 4 pm

#### BISSELL Homecare (Overseas) Inc.

The Boat Yard  
105 Straight Road  
Old Windsor  
Berkshire, SL4 2SE  
United Kingdom  
Telephone: 0870-225-0109

#### For Australian inquiries:

Monday - Friday 9 am — 5 pm

#### BISSELL AUSTRALIA PTY LIMITED

Unit 35  
15 Ricketts Road  
Mount Waverley, Victoria 3149  
Australia  
Telephone: 1-800-811-183

#### For New Zealand inquiries:

Monday - Friday 9 am — 5 pm

#### Parex Industries Ltd.

103 Central Park Drive  
Henderson  
Auckland  
New Zealand  
Telephone: 0800-247-735

#### For all other inquiries:

Monday - Friday 8 am — 4 pm

#### BISSELL Homecare, Inc.

PO Box 1888  
Grand Rapids, MI 49501 USA  
Telephone: 01-616-453-4451  
Fax: 01-616-453-1383

**BISSELL HOMECARE INC. IS NOT LIABLE FOR INCIDENTAL OR CONSEQUENTIAL DAMAGES OF ANY NATURE ASSOCIATED WITH THE USE OF THIS PRODUCT. BISSELL'S LIABILITY WILL NOT EXCEED THE PURCHASE PRICE OF THE PRODUCT.**

#### \*EXCEPTIONS AND EXCLUSIONS FROM THE TERMS OF THE LIMITED WARRANTY

**THIS WARRANTY IS EXCLUSIVE AND IN LIEU OF ANY OTHER WARRANTIES EITHER ORAL OR WRITTEN. ANY IMPLIED WARRANTIES WHICH MAY ARISE BY OPERATION OF LAW, INCLUDING THE IMPLIED WARRANTIES OF MERCHANTABILITY AND FITNESS FOR A PARTICULAR PURPOSE, ARE LIMITED TO THE TWO YEAR DURATION FROM THE DATE OF PURCHASE AS DESCRIBED ABOVE.**



©2007 BISSELL Homecare, Inc.  
Grand Rapids, Michigan  
All rights reserved. Printed in China  
Part Number 120-4011  
Rev 10/07  
Visit our website at:  
[www.bissell.com](http://www.bissell.com)

Scotchgard is a trademark of 3M

