

**Experts In Home Cleaning™**

# HEALTHYhome STEAM MOP™ max

## USER'S GUIDE

1957-F SERIES 220-240V

- 2 Thank You
- 3 Safety Instructions
- 4 Product View
- 5 Assembly
- 6 Special Features
- 6-8 Operations
- 9 Maintenance and Care
- 10 Troubleshooting
- 10 Replacement Parts
- 10 Additional Accessories
- 11 Warranty
- 12 Consumer Care



## Thanks for buying a BISSELL Healthy Home Steam Mop™ Max

We're glad you purchased a BISSELL Healthy Home Steam Mop Max. Everything we know about floor care went into the design and construction of this complete, high-tech home cleaning system.

Your BISSELL Healthy Home Steam Mop Max is well made, and we back it with a limited one year warranty. We also stand behind it with a knowledgeable, dedicated Consumer Care department, so, should you ever have a problem, you'll receive fast, considerate assistance.

My great-grandfather invented the floor sweeper in 1876. Today, BISSELL is a global leader in the design, manufacture, and service of high quality homecare products like your BISSELL Healthy Home Steam Mop Max.

Thanks again, from all of us at BISSELL.

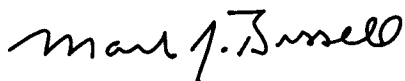

Mark J. Bissell  
Chairman & CEO

# IMPORTANT SAFETY INSTRUCTIONS

When using an electrical appliance, basic precautions should be observed, including the following:

## READ ALL INSTRUCTIONS BEFORE USING YOUR HEALTHY HOME STEAM MOP™ MAX.

Always connect to a properly Earthed outlet. Unplug from outlet when not in use and before conducting maintenance or troubleshooting.

### **WARNING:** To

reduce the risk of fire, electric shock, or injury:

- Use indoors only
- Do not immerse
- Use only on surfaces moistened by cleaning process
- Do not leave machine when it is plugged in
- Do not service machine when it is plugged in
- If the supply cord is damaged, it must be replaced by the manufacturer or its service agent in order to avoid a hazard
- Do not use machine if it has been dropped, damaged, left outdoors or dropped into water
- Do not expose to rain, store indoors
- Do not pull or carry by cord, use cord as a handle, close door on cord, pull cord around sharp corners or edges, run appliance over cord, or expose cord to heated surfaces
- Do not carry the appliance while in use
- Do not unplug by pulling on cord; unplug by grasping plug not the cord
- Do not handle plug or appliance with wet hands
- Do not put any object into appliance openings, use with blocked opening or restrict air flow
- Do not expose hair, loose clothing, fingers or body parts to openings or moving parts
- Do not pick up hot or burning objects
- Do not pick up flammable or combustible materials (lighter fluid, petrol, kerosene, etc.) or use in the presence of explosive liquids or vapours
- Do not use appliance in an enclosed space filled with vapours given off by oil base paint, paint thinner, some moth proofing substances, flammable dust, or other explosive or toxic vapours
- Remove plug from electrical outlet before cleaning or maintaining the appliance

- Not intended for use by persons (including children) with reduced physical, sensory or mental capabilities, or lack of experience and knowledge, unless they have been given supervision or instruction concerning use of the appliance by a person responsible for their safety
- Young children should be supervised to ensure that they do not play with the appliance
- Do not pick up toxic material (chlorine bleach, ammonia, drain cleaner, petrol, etc.)
- Do not modify the Earthed plug
- Do not allow to be used as a toy
- Do not use for any purpose other than described in this User's Guide
- Use only manufacturer's recommended attachments
- Use only cleaning products formulated by BISSELL for use in this appliance to prevent internal component damage
- Keep openings free of dust, lint, hair, etc.
- Keep appliance on a level surface
- Turn off all controls before unplugging
- Be extra careful when cleaning stairs
- Liquid or steam must not be directed towards equipment containing electrical components
- Pay close attention when working around children

## SAVE THESE INSTRUCTIONS

This model is for household use only.

 **WARNING:** This appliance must be Earthed.

 The symbol  means WARNING: Danger of scalding.

 Surface may be hot. Avoid contact.

**IMPORTANT** FOR OPERATION ON A 220-240 VOLT A.C. 50/60 Hz POWER SUPPLY ONLY.

If your appliance is fitted with a nonrewireable BS 1363 plug it must not be used unless a 13 amp (ASTA approved to BS 1362) fuse is fitted in the carrier contained in the plug. Spares may be obtained from your BISSELL supplier. If for any reason the plug is cut off, it must be disposed of, as it is an electric shock hazard should it be inserted into a 13 amp socket.

# Product view



**For replacement parts and accessories, see page 11**

# Assembly

**Your Healthy Home Steam Mop Max assembles quickly and easily. The only thing you will need for assembly is a Phillips head screwdriver.**

**Your Steam Mop is packaged with the following items:**

**Handle Assembly**

**Lower Body with Water Purification System**

**Maneuverable Swivel Head**

**Removable Water Tank**

**1 large Phillips Head Screw taped to the handle**

**1 small Phillips Head Screw taped to the handle**

**2 Deluxe Mop Pads**

1. Attach lower body to maneuverable swivel head.
2. Secure maneuverable swivel head with small Phillips head screw. Tighten until secure.
3. Slide handle assembly down into lower body until it will go no further.
4. Secure the handle by placing the large Phillips head screw through the screw opening in the lower body and into the rear of the handle assembly. Tighten with screwdriver until secure.
5. Slide water tank onto lower body by lining up vertical glides and gently sliding tank into place.

Healthy Home Steam Mop Max assembly is now complete.

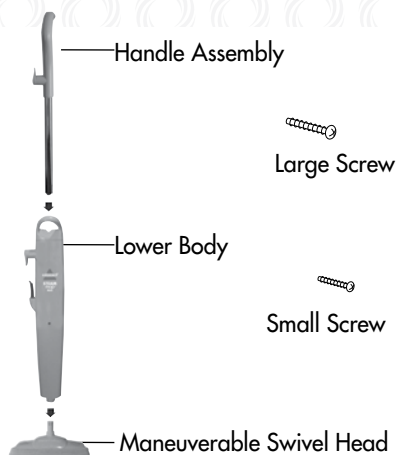

Removable Water Tank



2 Deluxe Mop Pads



1



2



3



4



5

*Tip:*

Do not attempt to use your Steam Mop without water in the tank.

# Assembly

## Special features

### Removable water tank

The water tank is located on the back of the Healthy Home Steam Mop Max. It can be refilled with water any time during use. Distilled or demineralized water may be used in place of tap water.

Do not use chemicals with your Steam Mop.

### Water purification system

This filter removes minerals and other impurities from tap water, preventing water deposits from damaging your Healthy Home Steam Mop Max. It should be replaced when the bright green grains turn blue. To maximize performance of the filter, distilled water may be used.

### Ready light

The ready light will glow when the Healthy Home Steam Mop Max is ready to use.

### Steam on demand trigger

Press to release steam.

### Maneuverable Swivel head

When cleaning in the manual mode, press the spray trigger to release water and formula onto the area to be cleaned.

### Deluxe mop pads

Reuseable microfiber mop pad is machine washable and safe for all hard floor surfaces.

# Operations

## Getting ready

**The mop pad may have already come attached to the swivel head, if not follow steps 1A and 1B below.**

1. Attach mop pad
  - A. Set swivel head in mop pad, making sure toggle is located on the back
  - B. Tighten mop pad by pulling on elastic drawstring while pressing on toggle.

*Tip:*

Do not attempt to use your Steam Mop without water in the tank.



More than 7 million Australians suffer from asthma and allergies. The Sensitive Choice program has been developed by the National Asthma Council Australia to help Australians and New Zealanders make better lifestyle choices that may help manage asthma and allergies more effectively.

The BISSELL range of steam mops, deep carpet cleaners and deep carpet cleaning formulas has been approved by the National Asthma Council Australia's Sensitive Choice program, and carries the Sensitive Choice butterfly logo. The Sensitive Choice blue butterfly symbol is a way of recognising products and services that support asthma and allergy care. Products that carry the blue butterfly may be better choices for people with asthma and allergies.

To learn more about managing asthma and allergies, visit the Sensitive Choice website at:

[www.sensitivechoice.com.au](http://www.sensitivechoice.com.au)

**1A**



**1B**



# Operations

## Getting ready continued

2. Fill the water tank
  - A. Remove tank by lifting straight up and away from unit.
  - B. Unscrew cap at bottom of water tank and remove the insert assembly.
  - C. Fill water tank with water. For best results, water should be at room temperature.
  - D. Replace insert assembly and cap, tighten until snug.
  - E. Replace water tank by lining up vertical guides and gently sliding tank into place.
3. Twist the quick release cord wrap clockwise to unwrap the power cord completely and plug into a 1 proper outlet as described on the Important Safety Instructions, page 3.
4. The ready light will illuminate when the Healthy Home Steam Mop Max is ready for use.

## Before you clean

Thoroughly sweep or vacuum floor prior to cleaning with the Healthy Home Steam Mop Max.

## Cleaning hard floors

Your Healthy Home Steam Mop Max is designed to clean hard flooring such as ceramic tile, vinyl, laminate, marble, stone and sealed hard wood floors. Use of your Healthy Home Steam Mop Max on waxed or some unwaxed floors may result in a diminished glossiness. The Healthy Home Steam Mop Max is not for use on unsealed wood floors. For best results test in an inconspicuous area and check the care instructions from your flooring manufacturer.

**IMPORTANT:** Sanitizing on timber floors is not recommended, as prolonged application of steam in one area increases the risk of damage to the surface treatment on timber floors, especially in areas with regular foot traffic and direct sunlight, which will wear down timber floor surface treatments, making it more susceptible to steam damage. See Caution to the right.

1. When the ready light illuminates, begin cleaning by slowly passing over surface while pressing the steam on demand trigger to emit steam as needed.

**NOTE:** The trigger does not need to be depressed at all times for Healthy Home Steam Mop Max to work satisfactorily

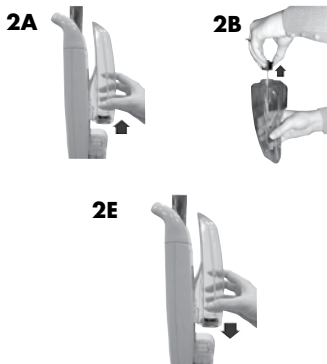

## **⚠️ WARNING:**

Never put descaling, aromatic, alcoholic, or detergent products into the steam cleaner, as this may damage it or make it unsafe for use.

## **⚠️ CAUTION:**

The Healthy Home Steam Mop Max generates hot steam, so when depressing the trigger to apply steam, ensure the Healthy Home Steam Mop Max is moving continuously. Prolonged application of steam in one area increases the risk of damage to the surface treatment of timber floors. Exercise extreme care when using the Steam Mop Max on timber flooring. Ensure the Steam Mop Max is thoroughly tested in an inconspicuous area prior to mopping a large floor area. The Steam Mop Max generates hot steam, so when depressing the trigger to apply steam, ensure the Steam Mop is moving continuously. The trigger does not need to be depressed at all times. Check with your timber floor treatment application specialist prior to Steam Mop Max operation.

# Operations

## Cleaning hard floors continued

2. To sanitize an area of your floor, (attack invisible germs and bacteria) place the center of the Healthy Home Steam Mop Max over the spot for a minimum 15 seconds, but no longer than 20 seconds. For larger areas, overlap swivel head placement.
3. When the Healthy Home Steam Mop Max stops emitting steam, simply remove the water tank, refill, and continue cleaning.

## Carpet Refresher Attachment

**This accessory is recommended for the refreshing of carpets. Once the Healthy Home Steam Mop Max is cradled in the carpet refresher attachment, it will easily glide over the carpet.**

**NOTE: Always be sure a mop pad is in place before placing in carpet refresher attachment. Only white mop pads should be used with the carpet attachment. Do not use carpet attachment on spots or stains, or glide it over the same spot for longer than 20 seconds.**

1. Attach the mop pad to the swivel mop head. As directed in step 1 on page 6.
2. Place the swivel mop head, with mop pad attached, in the carpet refresher attachment.  
**Note: that the Healthy Home Steam Mop Max rests in the carpet refresher attachment and may not stay attached to the swivel mop head. It is meant to glide over the carpet.**
3. Fill the water tank with water. Begin refreshing your carpet or rug by pushing the Healthy Home Steam Mop Max in a forward and backward motion, releasing steam as you go.
4. When you have finished refreshing your carpet or rug, unplug the Healthy Home Steam Mop Max and remove from the carpet or rug.

**NOTE: Move the Healthy Home Steam Mop Max and carpet refresher attachment in a continuous motion until you are finished. This product is not intended to be used as a carpet cleaner, only a carpet refresher or deodorizer. Never attempt to use the Healthy Home Steam Mop Max on carpet without the carpet refresher attachment in place. DO NOT leave the mop in a stationary position.**

### Tip:

During first use, it may take several seconds for the Steam Mop to begin steaming. The water needs to flow through the filter to the heater. This delay will only occur during initial use or when using a new filter.





# Maintenance and care

## When you're done

1. Unplug power cord from outlet.
2. Carefully remove mop pad from swivel head, as mop pad and lower assembly will be hot.
3. Any water remaining in the water tank should be emptied prior to machine storage.
4. Mop pad can be machine washed in warm water. Use only liquid detergents. Do not use bleach or fabric softeners. For best results, air dry.
5. Wrap power cord around quick release cord wrap on side of Healthy Home Steam Mop Max.
6. Wipe all surfaces of Healthy Home Steam Mop Max with a soft cloth. Store upright in a protected, dry area.

**NOTE: If steam output is reduced, the nozzle may be blocked. To remedy, unplug unit and allow to cool. Once cooled, remove swivel head from lower body and pour vinegar through center tube of swivel head "neck". Clear nozzle by inserting a paper clip into the brass spray tip located in bottom of lower body.**



## **CAUTION:**

Upright storage of the Steam Mop with a wet mop pad may result in the formation of white marks on your floor. To remove the white marks, clean area with vinegar.

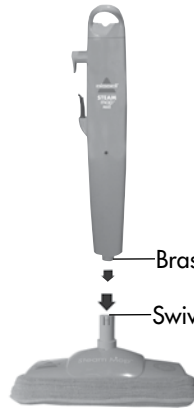

## Replacing the water purification system

If you fill your Healthy Home Steam Mop Max cleaner with normal tap water, it is essential to check the water purification system and replace it when it is no longer effective. Change the filter when the bright green grains turn blue. If the filter is not changed at the appropriate time, calcium deposits will accumulate on the heating element, causing damage or reduced performance.

Using distilled or demineralized water will maximize the performance of your filter.

To order a replacement water purification system refer to the replacement parts section on page 10.

*Tip:*

Using distilled or demineralized water will maximize the performance of your filter.

*Tip:*

Be sure to use only a BISSELL water filter in your Steam Mop.

# Troubleshooting

## Reduced steam or no steam.

### Possible Causes

1. Water tank empty
2. Depleted water filter
3. Blocked steam nozzle

### Remedies

1. Fill tank
2. Replace filter
3. Refer to NOTE on page 9

**Other maintenance or service not included in the manual should be performed by an authorized service representative.**

**Thank you for selecting a BISSELL product.**

**Please do not return this product to the store.**

## Replacement parts- BISSELL Healthy Home Steam Mop™ Max

Item	Part No.	Part Name
1	218-5600	Water Filter
2	203-8225	Handle Assembly with Screw
3	203-2159	Water Tank with Cap and Insert
4	603-2046	Cap and Insert Assembly
5	203-8226	Storage Hook with Screws



## Additional Accessories

**These items are available for purchase as accessories for your BISSELL Healthy Home Steam Mop Max:**

Item	Part No.	Part Name
1	49Q9	Deluxe Mop Pads - 2 pack
2	3252E	29.5 mL Eucalyptus & Mint Natural Aroma
3	90M7E	946 mL Eucalyptus & Mint Scented Water



# Warranty BISSELL Healthy Home Steam Mop™ Max

This warranty gives you specific legal rights, and you may also have other rights which may vary from country to country. If you need additional instruction regarding this warranty or have questions regarding what it may cover, please contact BISSELL Consumer Care by E-mail, telephone, regular mail as described below, or contact your local in country distributor.

## Limited One Year Warranty

Subject to the \*EXCEPTIONS AND EXCLUSIONS identified below, BISSELL will repair or replace (with new or remanufactured components or products), at BISSELL's option, free of charge from the date of purchase by the original purchaser, for one year any defective or malfunctioning part due to manufacturer defect.

This warranty applies to product used for personal, and not commercial or rental service. This warranty does not apply to fans or routine maintenance components such as filters. Damage or malfunction caused by negligence, abuse, neglect, unauthorized repair, or any other use not in accordance with the User's Guide is not covered.

BISSELL recommends that the original packaging be kept for the duration of the warranty period in case such need arises within the warranty period that the item need re-packing and transportation.

## BISSELL Consumer Care:

If your BISSELL product should require service or if you need information about repairs, authorized service centers in your area, replacement parts or your warranty, please contact BISSELL Consumer Care, as indicated below, or contact your local in-country distributor.

### For Australian inquiries:

Monday – Friday 9 am - 5 pm

#### **BISSELL AUSTRALIA PTY LIMITED**

42 Rocco Dr.

Scoresby 3179

Victoria

Australia

Telephone: 1.800.811.183

### For New Zealand inquiries:

Monday – Friday 9 am - 5 pm

#### **Parex Industries Ltd.**

5 Tolich Place

Henderson 0610

Auckland

New Zealand

Telephone: 0800.247.735

### For all other inquiries:

Monday – Friday 8 am - 4 pm

#### **BISSELL Homecare, Inc.**

PO Box 1888

Grand Rapids, Michigan 49501 USA

Telephone: 01.616.453.4451

Fax: 01.616.453.1383

## \*EXCEPTIONS AND EXCLUSIONS FROM THE TERMS OF THE LIMITED WARRANTY

BISSELL AND ITS IN-COUNTRY DISTRIBUTORS ARE NOT LIABLE FOR INCIDENTAL OR CONSEQUENTIAL DAMAGES OF ANY NATURE ASSOCIATED WITH THE USE OF THIS PRODUCT. BISSELL'S LIABILITY WILL NOT EXCEED THE PURCHASE PRICE OF THE PRODUCT.

THIS WARRANTY IS EXCLUSIVE AND IN LIEU OF ANY OTHER WARRANTIES EITHER ORAL OR WRITTEN. ANY IMPLIED WARRANTIES WHICH MAY ARISE BY OPERATION OF LAW, INCLUDING THE IMPLIED WARRANTIES OF MERCHANTABILITY AND FITNESS FOR A PARTICULAR PURPOSE, ARE LIMITED TO THE ONE YEAR DURATION FROM THE DATE OF PURCHASE AS DESCRIBED ABOVE.

**FOR AUSTRALIAN CONSUMERS ONLY:** OUR GOODS COME WITH GUARANTEES THAT CANNOT BE EXCLUDED UNDER THE AUSTRALIAN CONSUMER LAW. YOU ARE ENTITLED TO A REPLACEMENT OR REFUND FOR A MAJOR FAILURE AND FOR COMPENSATION FOR ANY OTHER REASONABLY FORESEEABLE LOSS OR DAMAGE. YOU ARE ALSO ENTITLED TO HAVE THE GOODS REPAIRED OR REPLACED IF THE GOODS FAIL TO BE OF ACCEPTABLE QUALITY AND THE FAILURE DOES NOT AMOUNT TO A MAJOR FAILURE.

THIS WARRANTY IS IN ADDITION TO OTHER RIGHTS OR REMEDIES UNDER LAW. NOTHING IN THIS WARRANTY EXCLUDES, LIMITS OR MODIFIES ANY LIABILITY OF BISSELL WHICH IS IMPOSED BY LAW, OR LIMITS OR MODIFIES ANY REMEDY AVAILABLE TO THE CONSUMER WHICH IS GRANTED BY LAW. TO MAKE A CLAIM UNDER THIS WARRANTY CONTACT BISSELL AUSTRALIA PTY LTD (DETAILS ABOVE). CONTACT BISSELL PRIOR TO RETURNING ANY GOODS. WHERE AGREED, BISSELL WILL REIMBURSE REASONABLE POSTAGE / HANDLING COSTS (IF ANY) FOR RETURNING GOODS TO BISSELL.

## **BISSELL** consumer care

### **If your BISSELL product should require service:**

In Australia or New Zealand, call BISSELL Consumer Care at the numbers below and we will give you the location of a BISSELL Authorized Service Center in your area. For all other countries, contact your local in country distributor for questions, service, or repair.

If you have questions about your warranty or need replacement parts please contact the numbers below.

#### **For Australian inquiries:**

Monday - Friday 9 am — 5 pm

#### **BISSELL AUSTRALIA PTY LIMITED**

42 Rocco Dr.

Scoresby 3179

Victoria

Australia

Telephone: 1-800-811-183

#### **For New Zealand inquiries:**

Monday - Friday 9 am — 5 pm

#### **Parex Industries Ltd.**

5 Tolich Place

Henderson 0610

Auckland

New Zealand

Telephone: 0800-247-735

#### **For all other inquiries:**

Monday - Friday 8 am — 4 pm

#### **BISSELL Homecare, Inc.**

PO Box 1888

Grand Rapids, MI 49501 USA

Telephone: 01-616-453-4451

Fax: 01-616-453-1383

Or visit the BISSELL website - **[www.bissell.com](http://www.bissell.com)**

When contacting BISSELL, have model number of cleaner available.

Please record your Model Number: \_\_\_\_\_

Please record your Purchase Date: \_\_\_\_\_

**NOTE: Please keep your original sales receipt. It provides proof of purchase date in the event of a warranty claim. See Warranty on page 11 for details.**



**Experts In Home Cleaning™**

©2012 BISSELL Homecare, Inc.  
Grand Rapids, Michigan  
All rights reserved. Printed in China  
Part Number 120-4474  
Rev 3/12  
Visit our website at:  
[www.bissell.com](http://www.bissell.com)

