

Terrco[®], Inc.

Model 3100-3P



OPERATING INSTRUCTIONS

MAINTENANCE INSTRUCTIONS

ILLUSTRATED PARTS LIST

Terrco[®], Inc.

222 1st Avenue NW • Watertown, SD 57201

Phone: (605) 882-3888 • Fax: (605) 882-0778 • Email: info@terrco.com

Model 3100-3P



HP/KW	25/18.6
SWEEP OF DISCS	28" (711 mm)
ABRASIVE PRESSURE	1090 lbs (494 kg)
WIDTH OF MACHINE	29-1/2" (749 mm)
LENGTH OF MACHINE	72-1/4" (1835 mm)
HEIGHT OF MACHINE	52" (1321 mm)
NET WEIGHT	1425 lbs (646 kg)
SHIPPING WEIGHT	1625 lbs (737 kg)
WATER TANK	20 gallon (75,7 L)
POWER CORD (4-4)	100 ft (30,5 m)

ELECTRICAL OPTIONS

VOLTAGE	230	460	230	460
PHASE	3	3	3	3
DRIVE	MANUAL	MANUAL	VARIABLE	VARIABLE
AMP DRAW	60	30	60	30
BREAKER (AMPS)	80-100	50	80-100	50
STONE HOLDER RPM	510	510	385-600	385-600

- Optimal for jobs exceeding 10,000 sq. ft.
- Despite the weight and size the 3100 can be easily maneuvered by a single person
- Uses Plug Stone Shape, Bolt on to Universal Tool Plate, or Speed Shift System
- Four 42 lbs. Pocket Weights
- Mild Steel or Stainless Steel Guards
- Stainless Steel Water Tank
- Wet/Dry Setup

PRODUCTION RATES

- Mastic removal rate of 1000 sq. ft. per hour
- Thin-Set removal rates of 1,500 sq. ft. per hour
- Thin-Mil coatings removal of 750 sq. ft. per hour
- Concrete polishing rates of 2,500 sq. ft. per polishing pad per hour (depending on grit)
- Rough Terrazzo rate of 1,500 sq. ft. per day

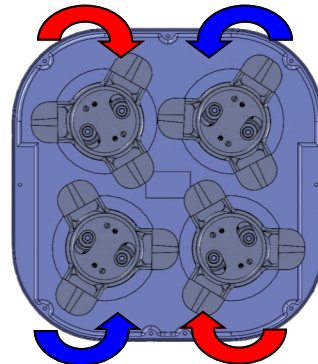

222 1st Avenue NW • Watertown, SD 57201
 Phone: (605) 882-3888 • Fax: (605) 882-0778
 Email: info@terrco.com • Website: www.terrco.com



SAFTY PRECAUTIONS

This machine is intended for commercial use. It is designed exclusively to grind and polish Terrazzo and concrete floors. Use only recommended accessories and abrasives. When the machine is in need of repair, use only Terrco parts. All operators must read, understand and practice the following safety precautions.



WARNING: Rotating grinding wheels can cause injury, keep hands and loose clothing clear.



WARNING: Disconnect power at the machine before servicing or changing grinding stones.







WARNING: Always check ground (earth) connection prior to operating machine.

For Safety:

- 1: Have electrician hook up power to machine.
- 2: Always operate machine with ground fault protection.
- 3: Eye, hearing and respiratory protection advised.
- 4: Service and adjust guards for maximum protection. Never remove the guards.
- 5: Keep machine clean and properly serviced.

SAFETY LABEL

The safety label is located on the machine as indicated below.
Replace label if it is damaged or illegible.

 WARNING FOR SAFETY, READ OWNERS MANUAL BEFORE USING MACHINE	
	ROTATING CUTTERS KEEP GUARDS IN PLACE AND ADJUSTED KEEP HANDS AND FEET AWAY WHEN OPERATING
	WEAR EYE AND HEARING PROTECTION WHILE OPERATING THE MACHINE
	GRINDING CAN GENERATE DUST. DUST MAY AFFECT THE BREATHING FUNCTION. AVOID DUST CONTACT BY USE OF MASK OR RESPIRATOR.
	DISCONNECT POWER AT THE MACHINE BEFORE SERVICING MACHINE OR CHANGING GRINDING STONES. ALWAYS CHECK GROUND (EARTH) PRIOR TO OPERATING MACHINE.



Operating Instructions

Introduction

This Manual has been prepared to assist and instruct you in the proper operation and maintenance of your machine. Please bear in mind that your Terrco® 3100 is a precision piece of machinery manufactured to exacting standards. In order for you to obtain maximum use of your Terrco® 3100, we suggest that you read this manual completely and thoughtfully before attempting to operate your machine. A parts diagram and parts reference sheet are included to assist you in ordering the proper parts. Always give the machine number and model number when ordering repair parts.

PRELIMINARY PROCEDURES TO FOLLOW BEFORE PUTTING THE 3100 IN OPERATION FOR THE FIRST TIME.

A. Delivery of the Machine

1. On delivery, the contractor should very carefully examine the shipping crate to see that no part of the machine is damaged. If damage is noted, request an inspection immediately and request a copy of the claim report. When accepting the machine from the delivering carrier, note the damage on the Freight Bill before signing. TERRCO® WILL NOT honor any claims for broken, damaged, or missing parts that may have occurred in shipment, as each machine is checked and inspected for the same, before leaving our plant.

B. Installation and Replacement of Grinding Stones

1. Move the counterbalancing weights to the upper weight baskets.
2. Using the flop handle, tilt machine back so that the caster wheel rests on the floor.
3. Clean mounting surface both on plug stone and stone holder. On 2" or 3" diameter plug stone, push stone in the hole and give the stone a slight twist to be certain it is securely in place.
4. Grasp machine handle and lower machine to the floor slowly so that all stones are resting on the floor. Make certain no stones have fallen or loosened while lowering the machine to the floor.

C. Transport of Machine

1. With counterbalancing weights in the upper weight baskets, tilt the machine so that the caster wheel is firmly on the floor. You can use the flop handle to pull the machine or you can fold the flop handle over and push from gear case side.

D. To operate the 3100

1. Disconnect electrical source.
2. Install stones per instructions in #1B.
3. After stones are installed, lower the machine until it is in operating position. CAUTION - Never attempt to start the machine while lowering machine to the floor, as rear stones will strike on corners resulting in thrown stones and possible damage to the machine.
4. Before plugging into the electrical system, check the voltage at the source. The minimum acceptable voltage is (210/420 Volt, 60 HZ, 3 phase), or (380 Volt, 50 HZ, 3 Phase). Anything lower than this can result in blown heaters and possible motor burnout.
5. If the machine is to operate in an area more than 100 feet from the source, it will be necessary to use the next larger size cable (#4-4) from the source to the 100 feet of #6-4 wire cable that was furnished with the machine.
6. After you have the cable in place, relieve pressure on the stones by applying your weight on the handle and push the start button on the starter switch, then releasing pressure on the handle to lower the machine to the floor.
7. We recommend that the first pass over the floor be made with the weights in the upper weight baskets. After the floor is "roughed" out, move the weights to the weight baskets located on the gear case for maximum abrasive pressure.
8. Be sure to periodically check stone wear, to prevent grinding with the steel plugs, rather than the stones.

Starting the 3100LP

E. To Start the 3100 LP Propane Engine

1. A 33 lb. special combination vertical-horizontal propane cylinder liquid withdrawal Model No. TU33L, must be used on this machine fitted with a Rego #7141 male fitting. The Terrco® 3100LP operates on the liquid principle.

2. When installing tanks, the bottom guide hole near the top of the cylinder must drop over the locating pin on the cylinder bracket of the handle. Connect quick coupler to the cylinder. DO NOT USE A WRENCH - only hand tighten.

3. You are now ready to open main gas valve in fuel tank. CAUTION - "SLOWLY" open main gas valve in the fuel tank. An abrupt full opening of the valve will induce dirt from within the tank to enter the fuel line. Too rapid an opening can also cause frost to form on the fuel filter, main valve, and inlet line. **CHECK FOR GAS LEAKS WITH SOAP SUDS SOLUTION. THERE MUST BE NO LEAK.**

4. Check oil level of crankcase.

5. Make certain clutch is disengaged.

6. Place weights in the "up" position.

7. Attach battery cables from starter to the battery.

8. Pull throttle knob a quarter to half way out.

9. Pull out ignition switch to "on" position and press rubber start button to start.

10. Allow engine to warm up approximately 10 minutes.

11. After a few minutes of warm-up and with weights in the upper weight baskets, pull throttle lever out to full open position, apply weight on the handle to relieve pressure on stones and engage clutch (pull clutch handle towards you).

NOTE: We recommend that for the first eight hours the machine be operated with the weights in the upper weight baskets to allow engine to break in without undue load factor.

12. After the initial eight hour engine break in period, we suggest that on all future operations, that you make your first "rough" grind operation with the weights in the upper weight baskets. You can then lower the weights to the lower weight baskets for the remaining portion of the rough grinding operation.

13. There may be excessive oil consumption during the first 10 days of operation during the break in period. If oil consumption is over 1 quart per day, contact you local AUTHORIZED WISCONSIN repair station.

14. CAUTION Do not operate Terrco®

General Maintenance for your TERRCO® 3100

A. Gear Case

1. Ref. #10 - Four grease fittings to be greased with 3 shots of Mobilith AW1 or the equivalent every six months.

2. Ref. #29 - The main gear box contains 28 pounds of Mobilith AW1. Check the level once a year by removing plug at the front of the gear case. Grease should be half-way up on the drive upper gear. **DO NOT FILL TO THE TOP.** The drive gear must not be covered, as you will create a condition of extreme pressure with resultant seal damage and grease leakage.

B. Spark Plugs

1. Every 100 hours or every two weeks check spark plug gap and reset. Use D9J (Champion) for LP gap at 0.030”.

C. Air Filter

1. Clean everyday.

D. Clutch (Dry) Special Feramic Face.

1. Your clutch will need adjustment if your clutch shows evidence of slipping or overheating.

2. To adjust clutch:

a. Close fuel shut off valve on tank.

b. Disconnect fuel line.

c. Remove inspection plate over clutch housing and follow directions in Wisconsin Manual.

E. Belt Replacement

1. Remove belt guard (Fig. 2)

2. Loosen locking nut on adjusting screw, (Fig. 2), and loosen adjusting screw.

3. Loosen three cap screws (Fig. 2) on idler bracket and push idler bracket forward.

4. Remove worn belt. With new belt positioned in their respective grooves on pinion sheave, pull belt out to you and position in respective grooves on idler bracket sheaves. Pull up and align belt on engine drive sheave.

5. Tighten adjusting screw until required belt tension is obtained. (Belt should compress no more than 1/16” with full thumb pressure midway between engine pulley and idler pulley) Tighten lock nut and then securely tighten three cap screws on idler pulley bracket.

6. Replace belt guard.

F. Timing of Stone Spiders

1. Whenever repairs are necessary in the gear case, which requires removal of the engine and pinion gear assembly, the following procedure is to be followed. Where gear replacement is necessary:

a. Remove belt guard, loosen idler bracket, remove belt.

b. Unbolt engine from mounting base.

c. Unbolt engine mounting base and remove.

d. Loosen and remove top bearing plates. Loosen and remove gear shaft lock nuts, top and bottom.

e. Loosen and remove all nuts, gear case cover and remove stone spider, morflex coupling, and driving spider.

IMPORTANT: After removing drive spider, be certain to remember or mark position of keyway relative to fixed position on gear case.

f. With drive shaft out, you are in a position to remove the damaged gear of shaft.

g. Position gear and shaft in case, aligning keyway in position marked on removal. Install lower bearing, grease seal, key, drive spider, lock nut, morflex coupling, and stone spider - in that order.

h. When you have installed the stone spider, it should be perfectly timed. If they are not, you are off on the alignment of the keyway and will have to adjust.

i. Timing drive gears - See Fig. 3 and follow instructions.

j. Install belt per instructions.

k. Install belt guards if furnished with machine.

MODEL 3100-3P

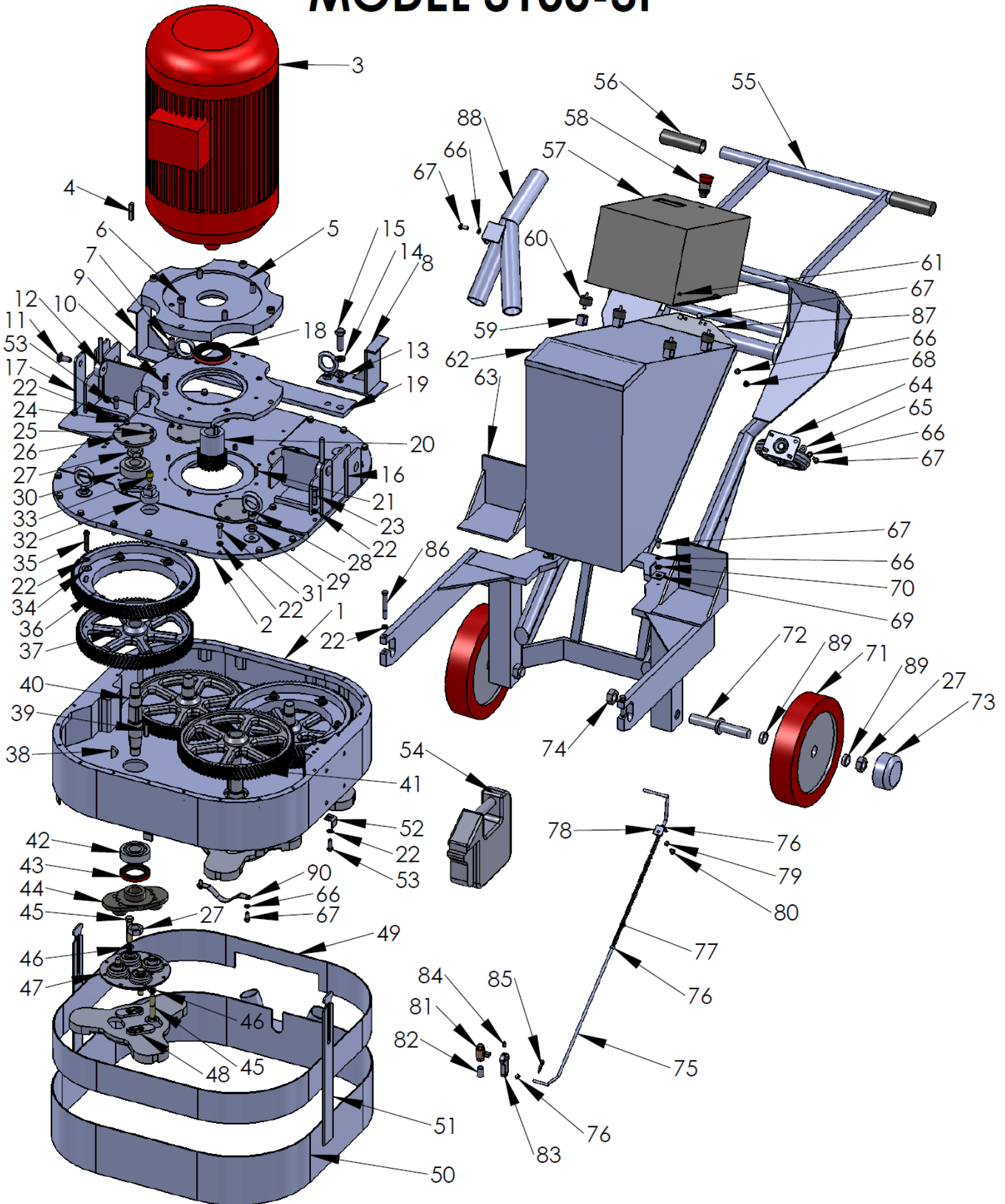

ITEM NO.	PART NUMBER	DESCRIPTION	QTY.
1	FE 304	GEAR CASE	1
2	FE 305	GEAR CASE LID	1
3	FE 146	25 HP, 230/460 V, 3 PH, 60 Hz	1
4	FE 193	PINION KEY	1
5	FE 130-HS	MOTOR PLATE	1
6	T3048	CAPSCREW	4
7	X 032	CAPSCREW	4
8	FE 298L	TILT STOP - LEFT HAND	1
9	FE 298R	TILT STOP - RIGHT HAND	1
10	T2111	CAPSCREW	4
11	FE 153	CARRIAGE BOLT	2
12	FEN 009	SPLASH GUARD LOCK NUT	2
13	Z06-1116	WASHER	2
14	T2140	LOCK WASHER	2
15	Z02-1485	CAPSCREW	2
16	FE 297L	WEIGHT AND LIFT BRACKET	1
17	FE 297R	WEIGHT AND LIFT BRACKET	1
18	FE 249	GREASE SEAL	1
19	FE 310	TILT STOP MOUNT	1
20	FE 005B	PINION 3100-3P	1
	FE 245	HIGH SPEED PINION	1
21	FD 040	DOWEL PIN	6
22	T1022	LOCK WASHER	48
23	T1097	CAPSCREW	6
24	170	GREASE ZERK	4
25	T3011	CAPSCREW	16
26	FE 027	BEARING CAP	4
27	T2008	LOCK NUT	10
28	X 016	LIFT RING	4
29	T3050	JAM NUT	4
30	SM 043, SM 037	BEARING CONE AND CUP	4
31	T1025	CAPSCREW	17
32	X 100	PIPE PLUG	1
33	DS 184	BREATHER CAP	1
34	T3028	WROUGHT WASHER	12
35	T2099	CAPSCREW	12
36	FE 125B	DRIVE GEAR	2
37	FE 004B	DRIVEN GEAR - RH	2
38	T 2012	WOODRUFF KEY	4
39	SM 072	HELICAL GEAR KEY	4
40	SM 016	HELICAL GEAR SHAFT	4

ITEM NO.	PART NUMBER	DESCRIPTION	QTY.
41	SM 015L	HELICAL GEAR - LH	2
42	SM 036, SM 037	BEARING CONE AND CUP	4
43	SM 169	GREASE SEAL	4
44	SM 500	DRIVE PLATE	4
45	SM 171	CAPSCREW	16
46	T1012	LOCK WASHER	16
47	SM 088	FLEXIBLE COUPLING	4
48	SM 491	SPEED SHIFT TOOL PLATE	4
	SM 192B	PLUG STONE HOLDER	4
	SM 492	UNIVERSAL TOOL PLATE	4
49	FE 021-SS	STATIONARY GUARD - SS	1
	FE 021	STATIONARY GUARD	1
50	FE 003-SS	ADJUSTABLE GUARD - SS	1
	FEN 010	ADJUSTABLE GUARD	1
51	FE 029	ADJUSTABLE GUARD STRAP	2
52	SM 028	GUARD BRACKET	9
53	T2013	CAPSCREW	13
54	FE 246	42 LB POCKET WEIGHT	4
55	FEN 027	HANDLE BAR	1
56	SM 057	HANDLE GRIPS	2
57	FE 276	INVERTER DRIVE 25 HP, 460 V, 3 PH	1
	FE 279	INVERTER DRIVE 25 HP, 230 V, 3 PH	1
	FE 142	MANUAL START 25 HP, 230 V, 3PH	1
	FE 142-380	MANUAL START 25 HP, 380 V, 3PH	1
	FE 142-415	MANUAL START 25 HP, 415 V, 3PH	1
	FE 142-460	MANUAL START 25 HP, 460 V, 3PH	1
58	LW 076	EMERGENCY STOP	1
59	X-84	SWITCH BOX MOUNTING BRACKET	4
60	FE 251	VIBRATION MOUNT	4
61	05-5010-9	HEX HEAD NUT	6
62	FE 031B-SS	WATER TANK	1
63	FE 272	CENTER WEIGHT BASKET	2
64	HB 088A	CASTER	1
65	T3015	WROUGHT WASHER	4
66	T1007	LOCK WASHER	9
67	T2130	CAPSCREW	9
68	T2025	HEX HEAD NUT	2
69	FE 133-SS	WATER TANK CLIP	2
70	T2148	WASHER	2
71	DS 007	12" WHEEL	2
72	FE 020B	WHEEL SHAFT	2
73	DS 005	WHEEL CAP	2

ITEM NO.	PART NUMBER	DESCRIPTION	QTY.
74	T 2007	JAM NUT	2
75	FE 078A	WATER TANK ROD	1
76	SM 186	LOCK COLLAR	3
77	SM 182	COMPRESSION SPRING	1
78	FD 043	WATER GUIDE BRACKET	1
79	T1030	LOCK WASHER	1
80	T2122	CAPSCREW	1
81	SM 174	WATER VALVE	1
82	SM 175	VALVE STEM	1
83	SM 170X	WATER LEVER	1
84	T3007	SET SCREW	1
85	T2082	COTTER PIN, 1/4 X 2 1/2	1
86	T3053	CAPSCREW	2
87	FE 074-SS	WATER TANK BRACKET	1
88	FE 266	Y-PIPE	1
89	T2141	WHEEL BEARING SPACER	4
90	SM 172	WATER HOSE GUIDE	1

NOT PICTURED

PART NUMBER	DESCRIPTION	QTY.
DS 135	6-4 Cable (460 Volt)	100'
DS 134	4-4 Cable (230 Volt)	100'
SM 424	MALE PLUG, 50A, 3 PH (460 Volt)	1
SM 425	FEMALE PLUG, 50A, 3 PH (460 Volt)	1
SM 489	MALE PLUG, 60A , 3 PH (230 Volt)	1
SM 490	FEMALE PLUG, 60A, 3 PH (230 Volt)	1
FE 207	VACUUM HOSE	
LW 078	BRUSH STRIP	
X-E353-RB	DUST SEAL	1
SM 173	36" Water Hose	1
X-49	Cord Connector	1
X 97	Straight Cord Connector	2
X 90	Connector Lock Nut	2
T1109	CABLE CONNECTOR	3
SM 176	Hose Clamp - Water Hose	2
T1065	Grease Zerk Cap	6
T1103	15" Cable Tie	2
T2129	RING TONGUE TERMINAL	3
ZKS120	NAME/SERIAL # PLATE	1
103508	DRIVE SCREW #2	2
T1040	GREASE (LBS)	20

WARRANTY CLAIM PROCEDURE

Each new machine is covered by two separate, distinct warranties—one on the machine and one on the electric motor of gasoline engine. Read VERY CAREFULLY the Terrco[®] warranty covering the machine, as this will tell you whether you have a warranty claim or not. If your machine is under warranty and malfunctions, determine whether your problem is electrical or mechanical, and do the following:

I. Electrical.

- A. Consult the list of authorized motor repair stations sent with the machine and locate the station nearest you.
- B. Contact the repair station, giving them the following information:
 - 1. Complete nameplate date from the motor.
 - 2. Tell them that the machine is a terrazzo grinding and polishing machine.
 - 3. Give them a description or rundown of the trouble.
 - 4. Inform them of the voltage and amperage readings

II. Mechanical

- A. Contact your Terrco[®] Distributor giving them the following:
 - 1. Model and date purchased.
 - 2. Horsepower.
 - 3. Accurate description of the malfunction.
- B. If there is no Terrco[®] Distributor in your area call or write to us with the above information.

LIMITED ONE YEAR WARRANTY

TERRCO[®], Inc. warrants the original purchaser of the Terrco[®] grinding equipment to be free from defects in materials and workmanship under normal use and service. Our obligation under this warranty shall be limited to the repair or exchange of any part or parts which may prove defective under normal use and service within one year from date of purchase by, the original purchaser, and which our examination shall disclose to our satisfaction to be defective.

All equipment returned for repairs or exchange must be returned to: TERRCO[®], Inc., at the purchaser's expense and within the warranty period. All repaired or exchanged equipment will be shipped back to the purchaser F.O.B. Watertown, South Dakota.

THIS WARRANTY IS EXPRESSLY IN LIEU OF ALL OTHER WARRANTIES EXPRESSED OR IMPLIED INCLUDING THE WARRANTIES OR MERCHANTABILITY AND FITNESS FOR USE AND ALL OTHER OBLIGATIONS OR LIABILITIES ON THE PART OF TERRCO[®], INC. AND WE NEITHER ASSUME OR AUTHORIZE ANY OTHER PERSON TO ASSUME FOR US, ANY OTHER LIABILITY IN CONNECTION WITH THE SALE OF THIS EQUIPMENT. SOME STATES DO NOT ALLOW THE EXCLUSIONS OR LIMITATIONS ON IMPLIED WARRANTIES OR DO NOT ALLOW THE EXCLUSION OF LIMITATION OF INCIDENTAL OR CONSEQUENTIAL DAMAGES, SO THE ABOVE EXCLUSIONS OR LIMITATIONS MAY NOT APPLY TO YOU. THIS WARRANTY SHALL NOT APPLY TO ANY EQUIPMENT OR PART THEREOF WHICH HAS BEEN SUBJECT TO ACCIDENT, NEGLIGENCE, ALTERATIONS, ABUSE, MISUSE, OR IMPROPER MAINTENANCE. TERRCO[®], INC. MAKES NO WARRANTIES WHATSOEVER IN RESPECT TO ACCESSORIES OR PARTS NOT MANUFACTURED OR SUPPLIED BY US.