

2021

KUANBO®

Professional Commercial
Display Products Manufacturer



SHENZHEN KUANBO KEJI CO., LTD

TEL: +86 13828816257

Add: 5th Floor, Building A, Jingang Technology Park,
Fuyong Qiaotou, Baoan District, Shenzhen

Website: <https://lcd-digitalsignage.com>



SCAN TO SHOP

SHENZHEN KUANBO KEJI CO., LTD
HUAKE LIMITED (HONGKONG)

About us

SHENZHEN KUANBO KEJI CO., LTD as one of Subsidiary of HUAKE LIMITED (Hong Kong), is a leading technology company in commercial digital displays in China, was founded in 2010 with 200 R & D employees, 300 core products, 150 million years Turnover.

KUANBO is the world's leading pioneer and leader in LCD display, providing premium, high-quality solutions for various applications in our surroundings. Retailers, militaries, businesses, government agencies, industrial facilities, medical institutions and public transportation sectors all depend on KUANBO's engineering excellence and patented manufacturing expertise.

"We expect every customer in the selection of KUANBO LCD products at the same time, more excellent quality satisfactory service, and look forward to become the company's long-term partners ", this is Kuanbo to do for every customer, the commitment, is also our assiduous pursuit of the goal and the ability of director.

Contents

01-06	LCD Video Wall
07-16	Interactive Whiteboard
17-24	LCD Advertising display
25-30	Commercial Digital LCD Display
31-38	Stretched LCD Bar Display
39-40	Customized Products
41-46	Video Wall Processor
47-50	KUANBO Projects
51-52	Certification

KUANBO DIGITAL SIGNAGE

LCD VIDEO
WALL

FD Series

LCD VIDEO WALL

FD Series

46'/47'/49'/55'



> FEATURES



Industrial grade DID LCD panel

High brightness, high definition,
anti-glare

Horizontal, vertical, special-shaped

Built-in intelligent temperature
control fan

High count point subtitle function



Customization of startup LOGO



180 whole perspective



Supports software dip switch function

*For details about supported models, see the specifications table

Industry Applications

Safety monitoring >

Video surveillance is widely used in many occasions because of its intuitionistic, accurate, timely and informative content. With the rapid development of computer, network, image processing and transmission technology, and the continuous development of video technology, the requirements of video display technology are becoming higher and higher. Most of the display equipment in the security monitoring industry works 24 hours a year. LCD Mosaic in the field of monitoring occupies a leading position in the field of security display with its outstanding color performance, high picture quality, low energy consumption, long life and other remarkable characteristics.



< Radio and television industry

The application of LIQUID crystal splicing in radio and television industry is more and more widely, and it is the general trend to change from analog circuit driven display system to all digital display system. LCD Mosaic large screen technology in the process of image display can fully realize digital processing, its stable performance; Excellent picture quality; High scalability, greatly improved radio and television field display system performance.



Food and beverage industry >

As the new center of world business, more and more international business activities are held, which brings great pressure to the transformation of catering industry to internationalization and informatization. Among them, diners, especially business guests, to represent the brand image, reflect the upgrade of the video equipment requirements are increasingly high, large screen, high definition products have become their favorite video terminals.



< Meeting splicing screen

Network meeting through the splicing of large screen display system for work report, can achieve text, sound, video, picture flexible display, fully mobilize participantsThe enthusiasm of the member's sensory perception greatly improved the effectiveness of the meeting. In addition the application of video conferencing makes more and more people begin to accept network video communication instead of face-to-face communication

KUANBO DIGITAL SIGNAGE



Product Features

- Industrial DID LCD screen, 4000:1 contrast; 10000K color temperature; Designed for video presentations
- Ultra-narrow bezel design, full HD, LED backlight, high stability, rich interfaces
- Industrial DID screen, can be placed horizontally or vertically
- Built-in OPS interface, easy for extension function
- Suit for KUANBO KB-FB2000 processor, support any angle irregular splicing, HIGH-DEFINITION 4K 8K video playback, infinite point-to-point stacking of picture base,
- Built-in random code generator can control the large screen splicing box to generate random code through RS232 communication port
- The splicing of the startup LOGO and no-signal LOGO enables you to configure the LOGO as required
- High definition big screen, the customer can set subtitle and it can be rolled on top of the screen

Product Parameters

Model	KB-FD460G-2
Screen Size	46"
Portion	16:9
Bazel	3.5mm
Resolution	1920(H)x1080(V)
Dot Pitch	0.53025 mm x 0.53025 mm
Response Time	8ms
Color	8 bit, 16.7m
Brightness	500cd/m ²
Constrast Ratio	4000:1
Color Temperature	10000K
Viewing Angel	178/178
Display Area	1018.6 mm(H)x572.67 mm(V)
Video Input	VGA1/ HDMI1/ BNC1/ DVI1/ RS232 1
Video Output	BNC1/ RS232 1
Power Supply	AC 100V~240V,50/60Hz,Universal,±10%
Power Consumption	200W (Normal mode) /0.5W (Standy)
Service Life	80000 hrs
Weight	21Kg
Outer size	1022(H) x 576.6(V) x108.9(D)mm (Typ.)46inch

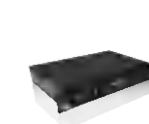

KB-FB2000



OPS Interface

Dimension

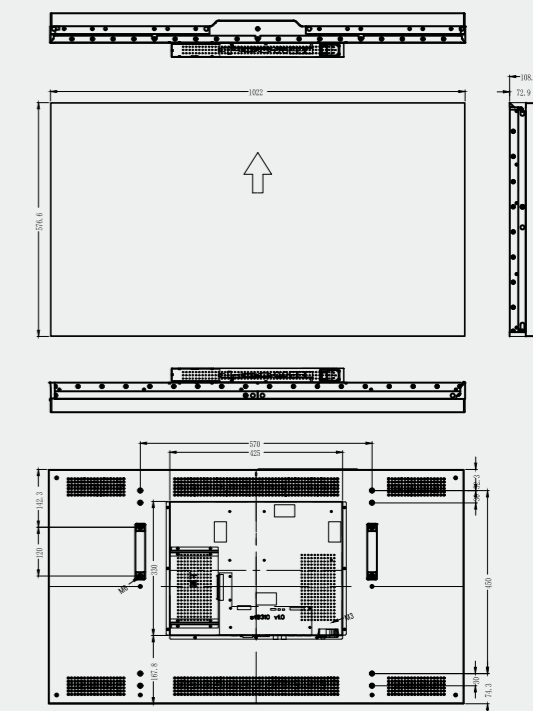

Product Features

- Industrial DID LCD screen, 4000:1 contrast; 10000K color temperature; Designed for video presentations
- Ultra-narrow bezel design, full HD, LED backlight, high stability, rich interfaces
- Industrial DID screen, can be placed horizontally or vertically
- Built-in OPS interface, easy for extension function
- Suit for KUANBO KB-FB2000 processor, support any angle irregular splicing, HIGH-DEFINITION 4K 8K video playback, infinite point-to-point stacking of picture base,
- Built-in random code generator can control the large screen splicing box to generate random code through RS232 communication port
- The splicing of the startup LOGO and no-signal LOGO enables you to configure the LOGO as required
- High definition big screen, the customer can set subtitle and it can be rolled on top of the screen



Product Parameters

Model	KB-FD490B
Screen Size	49"
Portion	16:9
Bazel	3.5mm
Resolution	1920(H)x1080(V)
Dot Pitch	0.55926 mm x 0.55926 mm
Response Time	8ms
Color	8 bit, 16.7m
Brightness	450cd/m ²
Constrast Ratio	1300:1
Color Temperature	10000K
Viewing Angel	178/178
Display Area	1074mm(H)x604.2 mm(V)
Video Input	VGA x1/ HDMIx1/ BNCx1/ DVIx1/ Rs232x1
Video Output	BNCx1/ RS232 x1
Power Supply	AC 100V~240V, 50/60Hz,Universal, ±10%
Power Consumption	160W (normal mood) /0.5W (standby)
Service Life	80000 hrs
Weight	18.5Kg
Outer size	1077.6(H)x607.8(V)x110.9(D) mm (Typ.)49inch



Dimension

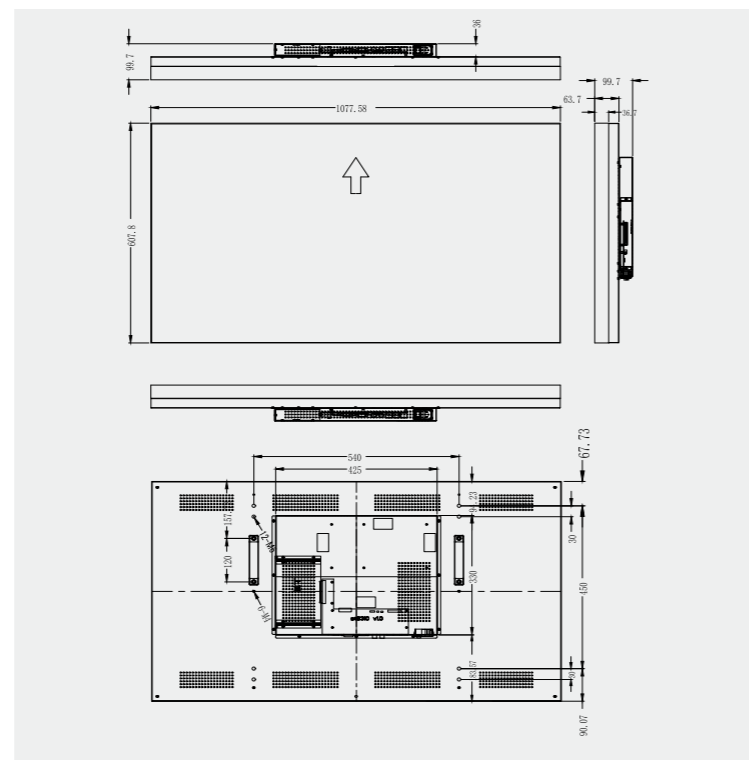

*Call us for detailed specifications: +86 138 2881 6257

Product Features

- Industrial DID LCD screen, 4000:1 contrast; 10000K color temperature; Designed for video presentations
- Ultra-narrow bezel design, full HD, LED backlight, high stability, rich interfaces
- Industrial DID screen, can be placed horizontally or vertically
- Built-in OPS interface, easy for extension function
- Suit for KUANBO KB-FB2000 processor, support any angle irregular splicing, HIGH-DEFINITION 4K 8K video playback, infinite point-to-point stacking of picture base,
- Built-in random code generator can control the large screen splicing box to generate random code through RS232 communication port
- The splicing of the startup LOGO and no-signal LOGO enables you to configure the LOGO as required
- High definition big screen, the customer can set subtitle and it can be rolled on top of the screen

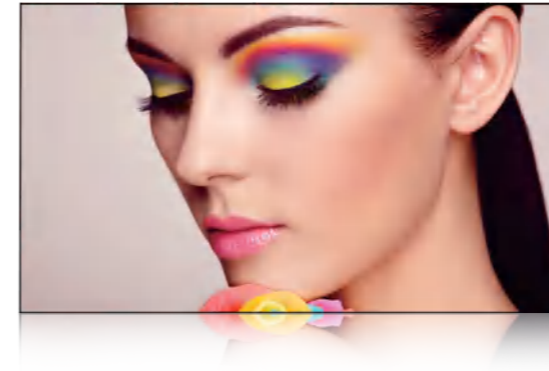

Product Parameters

Model	KB-FD550E-2
Screen Size	55"
Portion	16:9
Bazel	3.5mm
Resolution	1920(H)x1080(V)
Dot Pitch	0.630 mm x 0.630 mm
Response Time	8ms
Color	8 bit, 16.7m
Brightness	500cd/m ²
Constrast Ratio	4000:1
Color Temperature	10000K
Viewing Angel	178/178
Display Area	1209.6 mm(H)x680.4 mm(V)
Video Input	VGA x1/ HDMIx1/ BNCx1/ DVIx1/ RS232x1
Video Output	BNCx1/ RS232 x1
Power Supply	AC 100V~240V,50/60Hz,Universal,±10%
Power Consumption	200W (normal mood) /0.5W (standby)
Service Life	80000 hrs
Weight	28.5Kg
Outer size	1213.5(H) x 684.3 (V) x105.3(D) mm (Typ.)55inch



Dimension

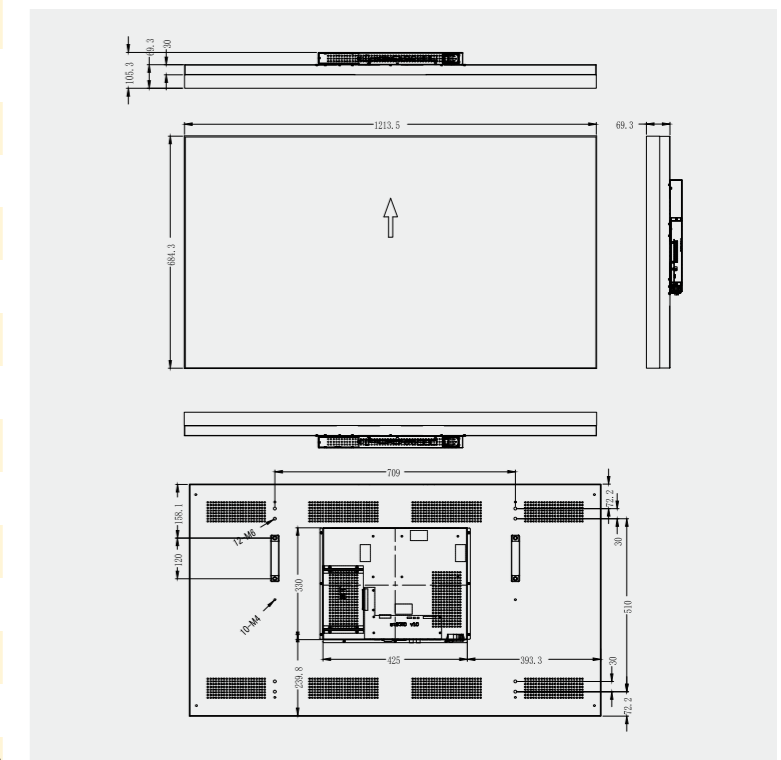

*Call us for detailed specifications: +86 138 2881 6257

Product Features

- Industrial DID LCD screen, 4000:1 contrast; 10000K color temperature; Designed for video presentations
- Ultra-narrow bezel design, full HD, LED backlight, high stability, rich interfaces
- Industrial DID screen, can be placed horizontally or vertically
- Built-in OPS interface, easy for extension function
- Suit for KUANBO KB-FB2000 processor, support any angle irregular splicing, HIGH-DEFINITION 4K 8K video playback, infinite point-to-point stacking of picture base,
- Built-in random code generator can control the large screen splicing box to generate random code through RS232 communication port
- The splicing of the startup LOGO and no-signal LOGO enables you to configure the LOGO as required
- High definition big screen, the customer can set subtitle and it can be rolled on top of the screen



Product Parameters

Model	KB-FD490S
Screen Size	49"
Portion	16:9
Bazel	1.8mm
Resolution	1920(H)x1080(V)
Dot Pitch	0.55926 mm x 0.55926 mm
Response Time	8ms
Color	8 bit, 16.7m
Brightness	450cd/m ²
Constrast Ratio	1300:1
Color Temperature	10000K
Viewing Angel	178/178
Display Area	1074mm(H)x604.2 mm(V)
Video Input	VGA x1/ HDMIx1/ BNCx1/ DVIx1/ Rs232x1
Video Output	BNCx1/x/ RS232 x1
Power Supply	AC 100V~240V,50/60Hz,Universal,±10%
Power Consumption	160W (normal mood) /0.5W (standby)
Service Life	80000 hrs
Weight	18.5Kg
Outer size	1075.6(H)x 605.8 (V)x110.9(D) mm (Typ.) 49inch



Dimension

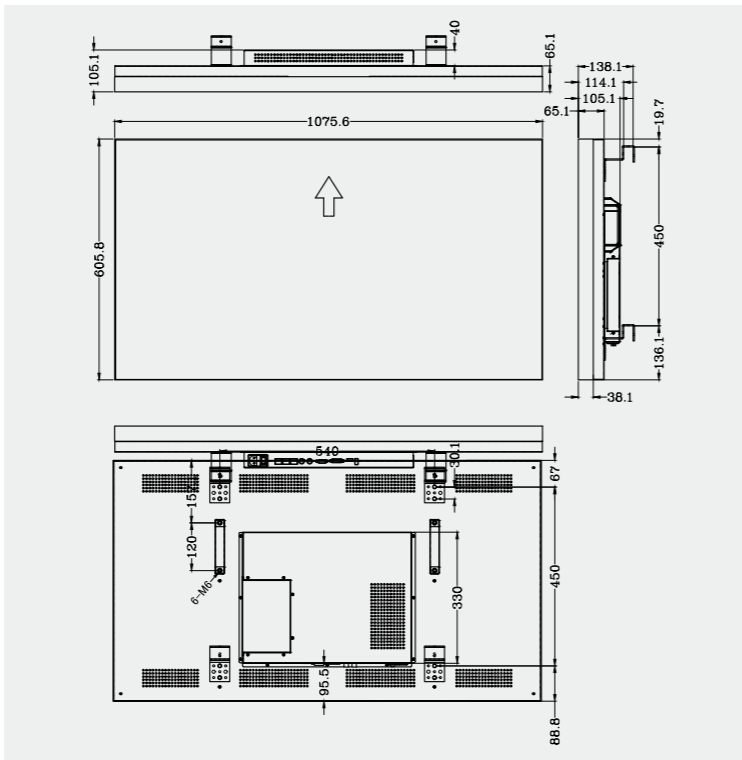

*Call us for detailed specifications: +86 138 2881 6257

Product Features

- Industrial DID LCD screen, 4000:1 contrast; 10000K color temperature; Designed for video presentations
- Ultra-narrow bezel design, full HD, LED backlight, high stability, rich interfaces
- Industrial DID screen, can be placed horizontally or vertically
- Built-in OPS interface, easy for extension function
- Suit for KUANBO KB-FB2000 processor, support any angle irregular splicing, HIGH-DEFINITION 4K 8K video playback, infinite point-to-point stacking of picture base,
- Built-in random code generator can control the large screen splicing box to generate random code through RS232 communication port
- The splicing of the startup LOGO and no-signal LOGO enables you to configure the LOGO as required
- High definition big screen, the customer can set subtitle and it can be rolled on top of the screen



Product Parameters

Model	KB-FD550S-2
Screen Size	55"
Portion	16:9
Bazel	1.7mm
Resolution	1920(H)x1080(V)
Dot Pitch	0.630 mm x 0.630 mm
Response Time	8ms
Color	8 bit, 16.7m
Brightness	500cd/m ²
Constrast Ratio	4000:1
Color Temperature	10000K
Viewing Angel	178/178
Display Area	1209.6 mm(H)x680.4 mm(V)
Video Input	VGA x1/ HDMIx1/ BNCx1/ DVIx1/ Rs232x1
Video Output	BNCx1/ RS232 x1
Power Supply	AC 100V~240V,50/60Hz,Universal,±10%
Power Consumption	200W (normal mood) /0.5W (standby)
Service Life	80000 hrs
Weight	28.5Kg
Outer size	1211.5(H) x 682.4 (V) x118.5(D) mm (Typ.) 55inch



Dimension

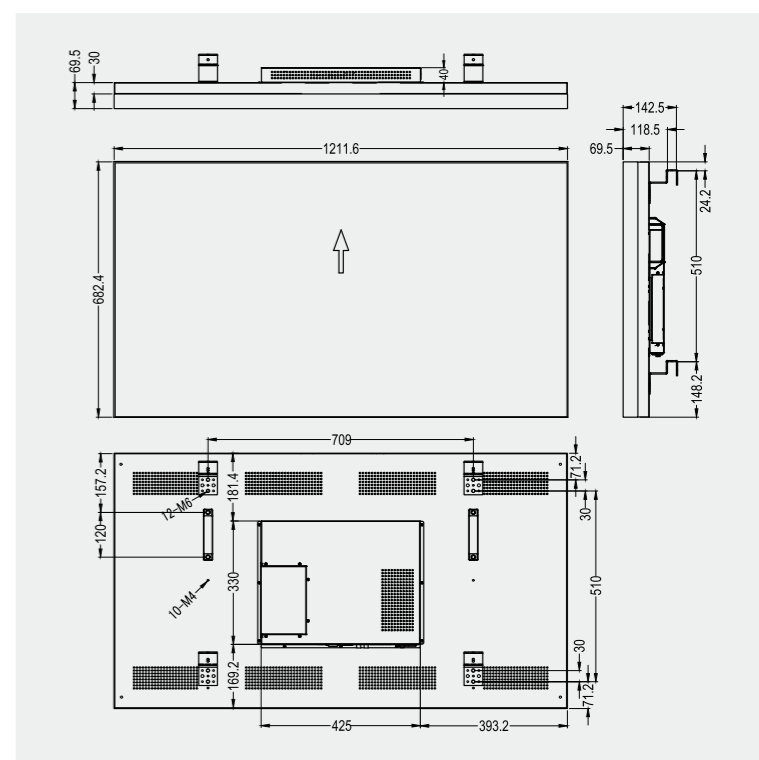

*Call us for detailed specifications: +86 138 2881 6257

INTERACTIVE WHITEBOARD

HD Series

KUANBO DIGITAL SIGNAGE

Interactive Whiteboard

HD Series

55'/65'/70'/75'/86'/98'



> FEATURES



Intelligent switch



Fast response, touch handwriting without delay



Super light protection screen, anti-glare design



Maintenance before touching the box



Contact mold remote diagnosis and calibration



Touch OSD touch menu



Supports OPS pluggable computers



Multi-touch support

*For details about supported models, see the specifications table

Industry Applications

Education industry >

Teaching touch all-in-one machine has the functions of teaching, academic report, conference, comprehensive discussion, demonstration and communication, remote teaching, remote marking, class, question setting, conference and so on. Touch function and intelligent management system and good audio and video effect; More can meet through the slide, projection film, multimedia courseware, video, material materials and other resources for comprehensive demonstration, discussion, live broadcast requirements, has a good visual effect, improve the strength and image of the school.



< Shopping mall navigation

Shopping mall navigation information management scheme is a leading media mode of using the Internet to release information. Combined with the demand for information release and service construction of shopping malls, it creates a new shopping service environment for shopping malls and pushes the new generation of professional information release form to a more advanced pattern. By installing multimedia display equipment in public areas such as mall entrance, lobby, elevator room and conference hall, it can realize not only shopping mall guide, advertising and promotion, but also play weather, scenic spots, traffic and other information.



Real estate industry >

Digital media marketing is under the new technical support system of media forms, such as digital magazine, digital newspapers, radio, SMS, mobile TV, web, desktop Windows, digital TV, digital movie, touch media, the sales, digital sand table, etc., this kind of media marketing with the help of simulation live such as sound, light, electricity, etc., Let the buyers in the visit can better experience the real estate project, enhance the interactive effect, so as to sell the effect.



< Banking application

Banks are the main channel for customer service and product sales. People put forward higher requirements for banking services, which also provides an application environment for the touch-control integrated machine to enter the business hall. Push and play new financial information and new banking business; The newspaper type advertising machine can realize the functions such as the joint delivery of electronic information advertising and DM direct leaflets, establish an efficient field management mechanism, and comprehensively improve the field user experience and efficiency.



KUANBO DIGITAL SIGNAGE

Product Features

- Support the OSD menu
- Support touch to wake up the dormant PC
- Support remote control (computer) one button machine turn on/off
- Supports OPS pluggable computers for future maintenance and replacement.
- Support Windows、Android、Linux、MAC OS。real Win7, Win8 free driver, no need to install program
- Reverse mirror: Wirelessly transmit TV images to mobile devices for display, And the use of mobile phones touch screen directly for multi-touch in the machine
- wireless image: Support for direct wireless transmission of the screen of iPhone, iPad, Android, MacBook and Windows computer to the machine, and support the reverse touch mobile device on the large screen at the same time, no need to connect to the touch control, VGA or HDMI cable.



Product Parameters

Model	KB-HD650C
Screen size	65"
Display portion	16:9
Display area	1428.48mm(H)x803.52mm(V)
Resolution	3840X2160 1920X1080
Dot Pitch	0.248(H)x0.744(V)
Response Time	8ms
Display Color	16.7m
Brightness	450cd/m ²
Contrast	1300:1
Color temperature	10000K
Viewing angle	178/178
Input interface	HDMI/ DP/ USB/ VGA / AV/ net/ RF/ PC AUDIO/ MINI YPBPR
Output interface	HDMI/ MINI AV/SPDIF
Front interface	8 buttons/ HDMI/PC USB/Android USB/ex. touch
Input voltage	AC 100V~240V,50/60Hz,Universal,±10%
Power consumption	185W (normal mood) /0.11 W (standby)
Touch type	80000 hrs
Touch resolution	28.5Kg
PC system	optional(customized)



Touch frame hand screw removable type



OPS pluggable computer

Dimension

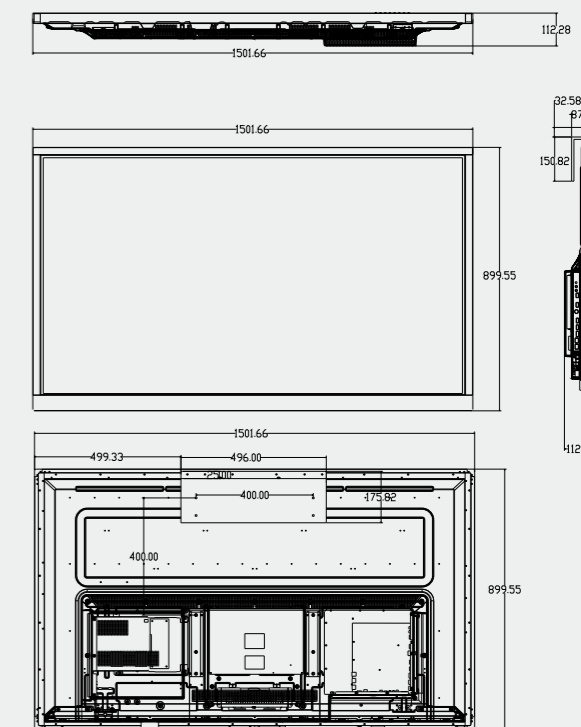

Product Features

- Support the OSD menu
- Support touch to wake up the dormant PC
- Support remote control (computer) one button machine turn on/off
- Supports OPS pluggable computers for future maintenance and replacement.
- Support Windows、Android、Linux、MAC OS。real Win7, Win8 free driver, no need to install program
- Reverse mirror: Wirelessly transmit TV images to mobile devices for display, And the use of mobile phones touch screen directly for multi-touch in the machine
- wireless image: Support for direct wireless transmission of the screen of iPhone, iPad, Android, MacBook and Windows computer to the machine, and support the reverse touch mobile device on the large screen at the same time, no need to connect to the touch control, VGA or HDMI cable.



Product Parameters

Model	KB-HD700C
Screen size	70"
Display portion	16:9
Display area	1538.88mm(H)×865.62mm(V)
Resolution	1920X1080
Dot Pitch	0.2672(H)×0.8015(V)
Response Time	8ms
Display Color	16.7m
Brightness	350cd/m ²
Contrast	4000:1
Color temperature	10000K
Viewing angle	178/178
Input interface	HDMI/ DP/ USB/ VGA / AV/ net/ RF/ PC AUDIO/ MINI YPBPR
Output interface	HDMI/ MINI AV/SPDIF
Front interface	8 buttons/ HDMI/PC USB/Android USB/ex. touch
Input voltage	AC 100V~240V,50/60Hz,Universal,±10%
Power consumption	205W (normal mood) /0.11 W (standby)
Touch type	Infrared multi-touch
Touch resolution	32768X32768
PC system	optional(customized)



Touch frame hand screw removable type OPS pluggable computer

Dimension

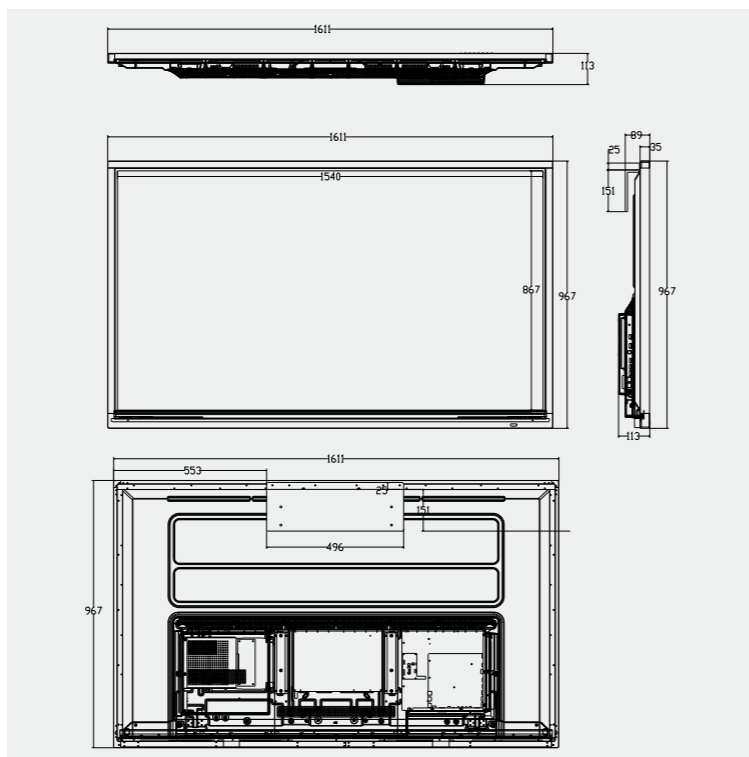

Product Features

- Support the OSD menu
- Support touch to wake up the dormant PC
- Support remote control (computer) one button machine turn on/off
- Supports OPS pluggable computers for future maintenance and replacement.
- Support Windows、Android、Linux、MAC OS。real Win7, Win8 free driver, no need to install program
- Reverse mirror: Wirelessly transmit TV images to mobile devices for display, And the use of mobile phones touch screen directly for multi-touch in the machine
- wireless image: Support for direct wireless transmission of the screen of iPhone, iPad, Android, MacBook and Windows computer to the machine, and support the reverse touch mobile device on the large screen at the same time, no need to connect to the touch control, VGA or HDMI cable.



Product Parameters

Model	KB-HD750C
Screen size	75"
Display portion	16:9
Display area	1649.66mm(H)×927.94mm(V)
Resolution	3840X2160 1920X1080
Dot Pitch	0.248(H)×0.744(V)
Response Time	8ms
Display Color	16.7m
Brightness	450cd/m ²
Contrast	1300:1
Color temperature	10000K
Viewing angle	178/178
Input interface	HDMI/ DP/ USB/ VGA / AV/ net/ RF/ PC AUDIO/ MINI YPBPR
Output interface	HDMI/ MINI AV/SPDIF
Front interface	8 buttons/ HDMI/PC USB/Android USB/ex. touch
Input voltage	AC 100V~240V,50/60Hz,Universal,±10%
Power consumption	185W (normal mood) /0.11 W (standby)
Touch type	80000 hrs
Touch resolution	28.5Kg
PC system	optional(customized)



Touch frame hand screw removable type OPS pluggable computer

Dimension

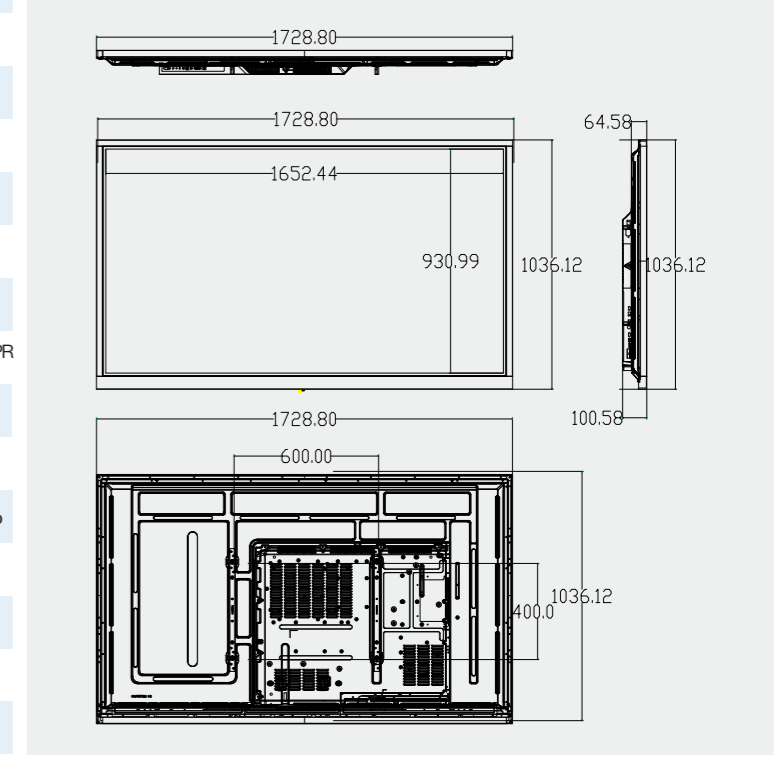

Product Features

- Support the OSD menu
- Support touch to wake up the dormant PC
- Support remote control (computer) one button machine turn on/off
- Supports OPS pluggable computers for future maintenance and replacement.
- Support Windows、Android、Linux、MAC OS。real Win7, Win8 free driver, no need to install program
- Reverse mirror: Wirelessly transmit TV images to mobile devices for display, And the use of mobile phones touch screen directly for multi-touch in the machine
- wireless image: Support for direct wireless transmission of the screen of iPhone, iPad, Android, MacBook and Windows computer to the machine, and support the reverse touch mobile device on the large screen at the same time, no need to connect to the touch control, VGA or HDMI cable.



Product Parameters

Model	KB-HD860C
Screen size	86"
Display portion	16:9
Display area	1895.88mm(H)×1066mm(V)
Resolution	1920X1080
Dot Pitch	0.2672(H)×0.8015(V)
Response Time	8ms
Display Color	16.7m
Brightness	350cd/m ²
Contrast	4000:1
Color temperature	10000K
Viewing angle	178/178
Input interface	HDMI/ DP/ USB/ VGA / AV/ net/ RF/ PC AUDIO/ MINI YPBPR
Output interface	HDMI/ MINI AV/SPDIF
Front interface	8 buttons/ HDMI/PC USB/Android USB/ex. touch
Input voltage	AC 100V~240V, 50/60Hz,Universal, ±10%
Power consumption	205W (normal mood) /0.11 W (standby)
Touch type	Infrared multi-touch
Touch resolution	32768X32768
PC system	optional(customized)



Touch frame hand screw removable type



OPS pluggable computer

Dimension

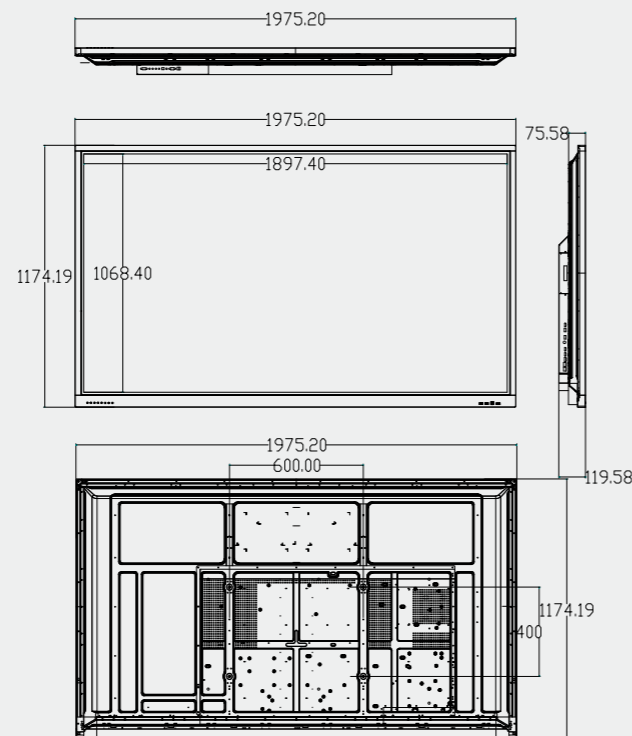

Product Features

- Support the OSD menu
- Support touch to wake up the dormant PC
- Support remote control (computer) one button machine turn on/off
- Supports OPS pluggable computers for future maintenance and replacement.
- Support Windows、Android、Linux、MAC OS。real Win7, Win8 free driver, no need to install program
- Reverse mirror: Wirelessly transmit TV images to mobile devices for display, And the use of mobile phones touch screen directly for multi-touch in the machine
- wireless image: Support for direct wireless transmission of the screen of iPhone, iPad, Android, MacBook and Windows computer to the machine, and support the reverse touch mobile device on the large screen at the same time, no need to connect to the touch control, VGA or HDMI cable.



Product Parameters

Model	KB-HD980C
Screen size	98"
Display portion	16:9
Display area	2158.66mm(H)×1214.94mm(V)
Resolution	1920X1080
Dot Pitch	0.1432(H)×0.4296(V)
Response Time	8ms
Display Color	16.7m
Brightness	400cd/m ²
Contrast	4000:1
Color temperature	10000K
Viewing angle	178/178
Input interface	HDMI/ DP/ USB/ VGA / AV/ net/ RF/ PC AUDIO/ MINI YPBPR
Output interface	HDMI/ MINI AV/SPDIF
Front interface	8 buttons/ HDMI/PC USB/Android USB/ex. touch
Input voltage	AC 100V~240V,50/60Hz,Universal,±10%
Power consumption	205W (normal mood) /0.11 W (standby)
Touch type	Infrared multi-touch
Touch resolution	32768X32768
PC system	optional(customized)



Touch frame hand screw removable type



OPS pluggable computer

Dimension

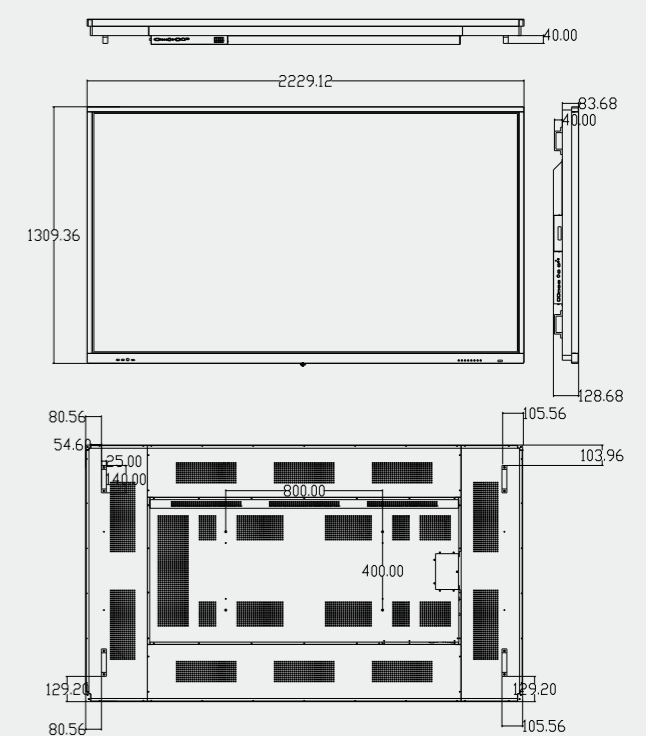

LCD ADVERTISING DISPLAY

X/L Series

GIORDANO Junior

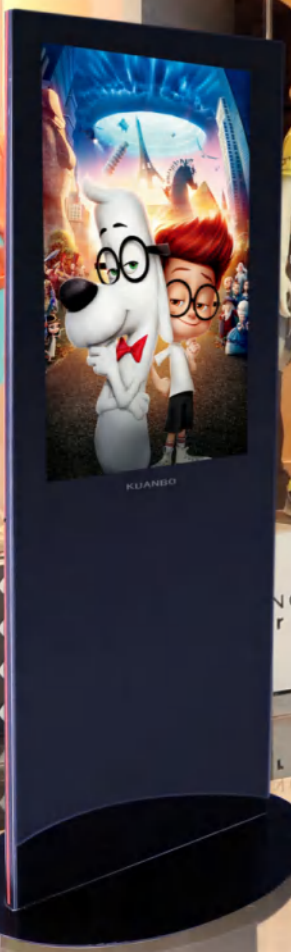

KUANBO DIGITAL SIGNAGE

LCD Advertising Display

X/L Series

32'/43'/55'/65'



> FEATURES



Supports horizontal/vertical playback



Start up automatic loop play



Intelligent turn on/off



Support AD video interspersions function



Supports full-screen playback and split-screen display



Remote upgrade install and uninstall programs and release information



Support breakpoint memory playback function

*For details about supported models, see the specifications table

Industry Applications

The financial industry >

Bank online advertising function to help financial institutions to promote the brand and business. Users will use the system to broadcast financial information such as benchmark interest rates, show and introduce bank jobs business and activity announcements to customers, and broadcast corporate culture promotion videos. Advertising machine can also complete more system functions, such as queuing, touch screen, multimedia terminal, etc., to reach the consistent management of information, so as to bring considerable economic effects for the financial profession.



< The retail industry

Commercial advertising machine, can help users to publish the latest shopping guide, products and promotional information. The rich display function and bright color of the advertising machine can help enhance the shopping experience of consumers, together with help users to simplify the information dissemination process, ultimately improve the sales performance of retail professional users.



The hotel industry >

The network advertising machine can be displayed in the public area of the hotel to provide customers with a full range of service information. For example: hotel map, room use, cuisine recommendation, promotional activities and other information content. In addition, when there is demand, the Net can also open up related hotel operation support according to the hotel's original system, such as automatic registration and check number services.



< The health care industry

Network advertising machine, medical institutions can broadcast medicine, registration, hospitalization and other related information. In addition, the advertising machine system solution can also be used to make doctor-patient interaction, provide map guidance, entertainment information and other content services, not only to simplify the treatment process, but also to reduce the anxiety of patients.

KUANBO DIGITAL SIGNAGE

Product Features

- Support real-time management and release on mobile, iPad and PC
- Support remote upgrade of advertising player software version and OTA upgrade
- Support the advertising machines in the same group can be played synchronously and the synchronization interval is less than 500ms
- Support the mobile phone to remotely set the properties of the advertising player, control the volume, rotation angle, time zone, turn off and turn on the advertising player
- Support remote monitoring of the network status, system status and hardware status of the advertising player, and monitor the content of the advertising player
- Support the needs of multiple forms of rolling subtitles and bullet screens, the font, size and content of subtitles and bullet screens can be edited
- Scheduling supports multiple priority levels, and supports shim/normal/interrupt/emergency message priority



Product Parameters

Model	KB-X220A
Screen size	21.5"
Display portion	16:9
Back light	LED
Contrast	1300: 1
Brightness	250cd/m ²
Response Time	6.5mS
Viewing angle	178(H)/178(V)
Module function	cable,WIFI,8G SD card/3G、4G optional
Color	black/silver Aluminium alloy frame
Operating system	Android 7.1
CPU	Six core dual-core ARM-A72+quad-core ARM-A53 2.0GHz
DDR	2G
NAND FLASH	8G
WIFI	2.4G 802.11b/g/n
USB	USB2.0
Menu language	Chinese, English
Rated power	≤80W
Net weight	14KG
Product size	522.74*314.2*62MM



Dimension

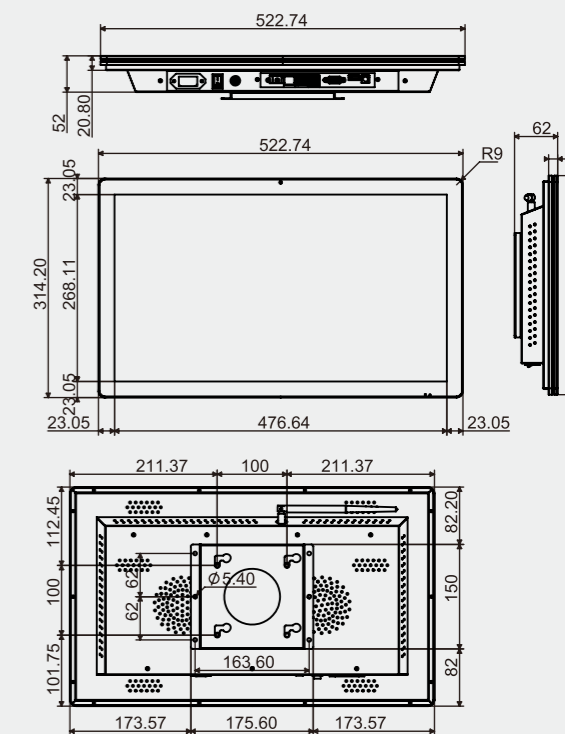

Product Features

- Support real-time management and release on mobile, iPad and PC
- Support remote upgrade of advertising player software version and OTA upgrade
- Support the advertising machines in the same group can be played synchronously and the synchronization interval is less than 500ms
- Support the mobile phone to remotely set the properties of the advertising player, control the volume, rotation angle, time zone, turn off and turn on the advertising player
- Support remote monitoring of the network status, system status and hardware status of the advertising player, and monitor the content of the advertising player
- Support the needs of multiple forms of rolling subtitles and bullet screens, the font, size and content of subtitles and bullet screens can be edited
- Scheduling supports multiple priority levels, and supports shim/normal/interrupt/emergency message priority



Product Parameters

Model	KB-X430A
Screen size	43"
Display portion	16:9
Back light	LED
Contrast	1300: 1
Brightness	300cd/m ²
Response Time	6.5mS
Viewing angle	178(H)/178(V)
Module function	cable,WIFI,8G SD card/3G、 4G optional
Color	black/silver Aluminium alloy frame
Operating system	Android 5.1
CPU	four core Cortex-A17 frequency 1.8G
DDR	2G
NAND FLASH	8G
WIFI	2.4G 802.11b/g/n
USB	USB2.0
Menu language	Chinese, English
Rated power	≤100W
Net weight	26KG
Product size	1010.8*599*82.3



Dimension

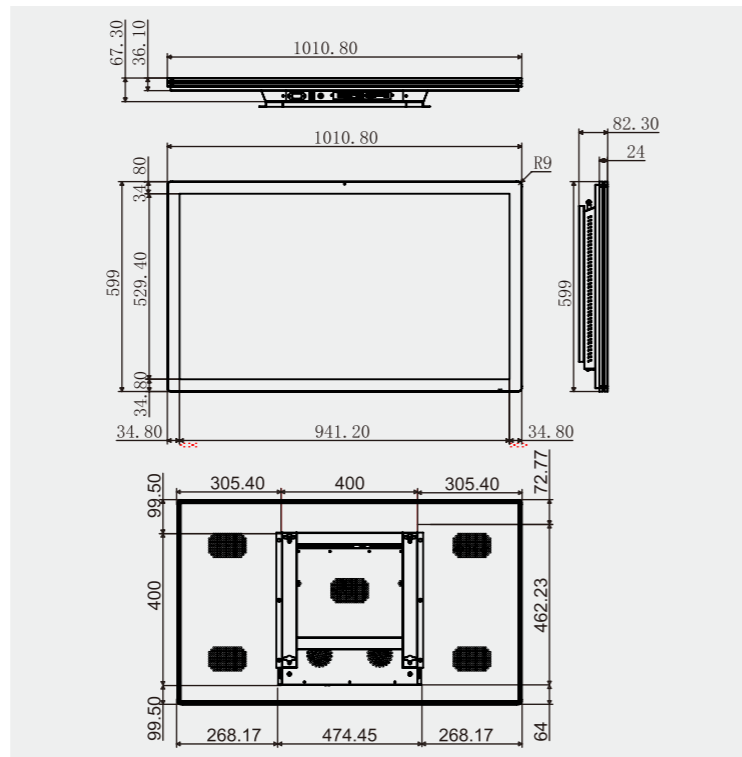

Product Features

- Support real-time management and release on mobile, iPad and PC
- Support remote upgrade of advertising player software version and OTA upgrade
- Support the advertising machines in the same group can be played synchronously and the synchronization interval is less than 500ms
- Support the mobile phone to remotely set the properties of the advertising player, control the volume, rotation angle, time zone, turn off and turn on the advertising player
- Support remote monitoring of the network status, system status and hardware status of the advertising player, and monitor the content of the advertising player
- Support the needs of multiple forms of rolling subtitles and bullet screens, the font, size and content of subtitles and bullet screens can be edited
- Scheduling supports multiple priority levels, and supports shim/normal/interrupt/emergency message priority



Product Parameters

Model	KB-X550A
Screen size	55"
Display portion	16:9
Back light	LED
Contrast	1300: 1
Brightness	400cd/m ²
Response Time	6.5mS
Viewing angle	178(H)/178(V)
Module function	cable,WIFI,8G SD card/3G、 4G optional
Color	black/silver Aluminium alloy frame
Operating system	Android 5.1
CPU	eight core Cortex-A53 frequency 1.5G
DDR	4G
NAND FLASH	64G
WIFI	2.4G 802.11b/g/n
USB	USB2.0
Menu language	Chinese, English
Rated power	≤160W
Net weight	33KG
Product size	1284.9*755.9*86.3MM



Dimension

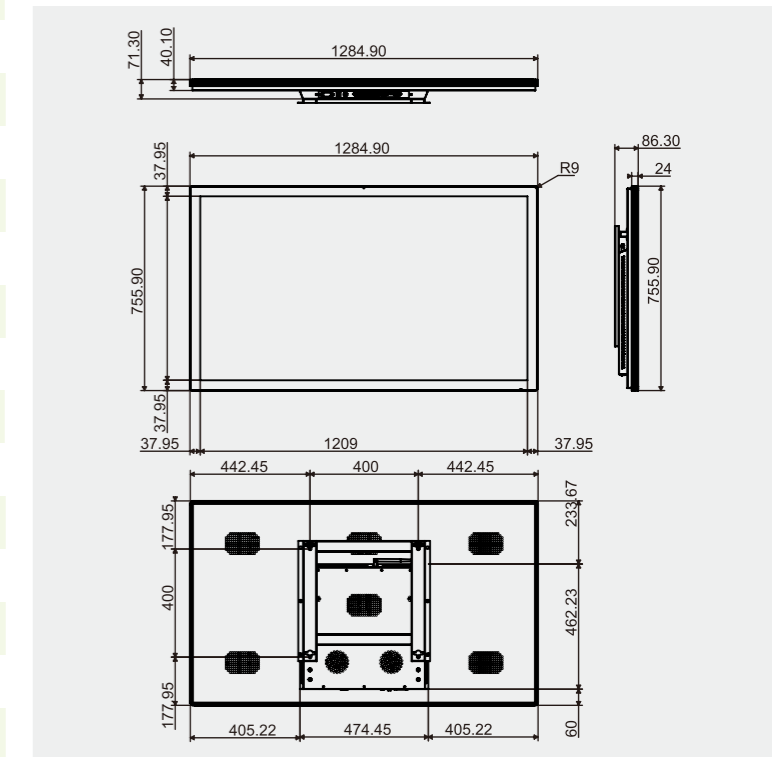



Product Features

- Support real-time management and release on mobile, iPad and PC
- Support remote upgrade of advertising player software version and OTA upgrade
- Support the advertising machines in the same group can be played synchronously and the synchronization interval is less than 500ms
- Support the mobile phone to remotely set the properties of the advertising player, control the volume, rotation angle, time zone, turn off and turn on the advertising player
- Support remote monitoring of the network status, system status and hardware status of the advertising player, and monitor the content of the advertising player
- Support the needs of multiple forms of rolling subtitles and bullet screens, the font, size and content of subtitles and bullet screens can be edited
- Scheduling supports multiple priority levels, and supports shim/normal/interrupt/emergency message priority

Product Parameters

Model	KB-L430A
Screen size	43"
Display portion	16:9
Back light	LED
Contrast	1300: 1
Brightness	300cd/m ²
Response Time	6.5ms
Viewing angle	178(H)/178(V)
Module function	cable,WIFI,8G SD card/3G、 4G optional
Color	black/silver Aluminium alloy frame
Operating system	Android 5.1
CPU	four core Cortex-A17 frequency 1.8G
DDR	2G
NAND FLASH	8G
WIFI	2.4G 802.11b/g/n
USB	USB2.0
Menu language	Chinese, English
Rated power	≤100W
Net weight	26KG
Product size	1800*45*599

Dimension

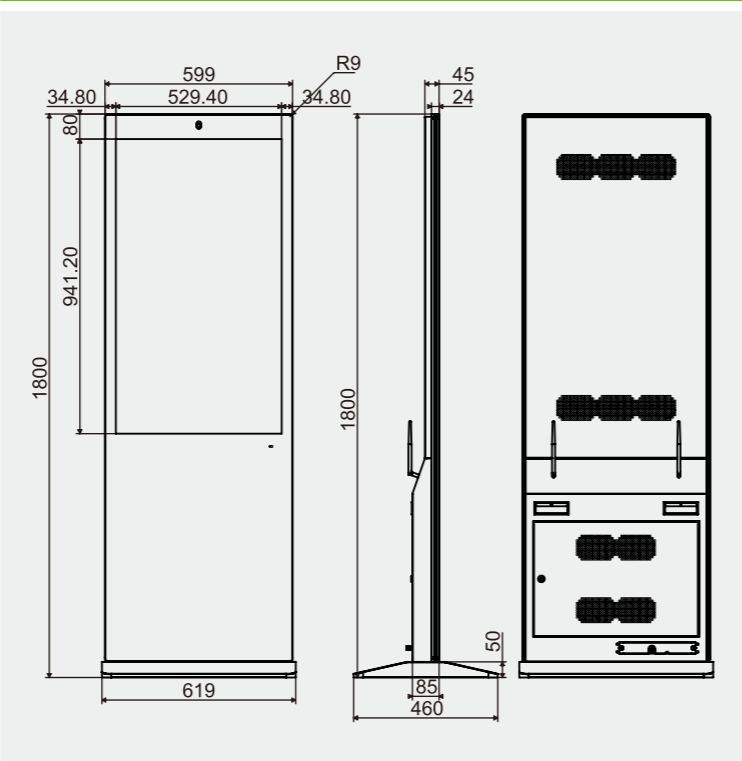

Product Features

- Support real-time management and release on mobile, iPad and PC
- Support remote upgrade of advertising player software version and OTA upgrade
- Support the advertising machines in the same group can be played synchronously and the synchronization interval is less than 500ms
- Support the mobile phone to remotely set the properties of the advertising player, control the volume, rotation angle, time zone, turn off and turn on the advertising player
- Support remote monitoring of the network status, system status and hardware status of the advertising player, and monitor the content of the advertising player
- Support the needs of multiple forms of rolling subtitles and bullet screens, the font, size and content of subtitles and bullet screens can be edited
- Scheduling supports multiple priority levels, and supports shim/normal/interrupt/emergency message priority

Product Parameters

Model	KB-L550A
Screen size	55"
Display portion	16:9
Back light	LED
Contrast	1300: 1
Brightness	400cd/m ²
Response Time	6.5ms
Viewing angle	178(H)/178(V)
Module function	cable,WIFI,8G SD card/3G、 4G optional
Color	black/silver Aluminium alloy frame
Operating system	Android 5.1
CPU	eight core Cortex-A53 frequency 1.5G
DDR	4G
NAND FLASH	64G
WIFI	2.4G 802.11b/g/n
USB	USB2.0
Menu language	Chinese, English
Rated power	≤160W
Net weight	33KG
Product size	1900*755.9*45MM

Dimension

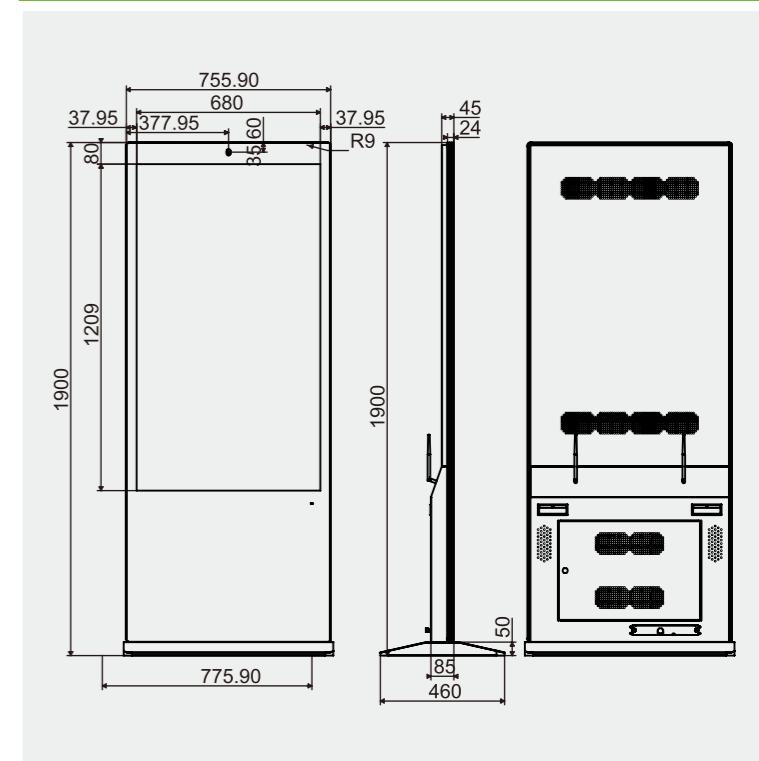

THE MONITOR

JP Series

Commercial monitor display

JP Series

55'/65'/70'/86'/98'



> FEATURES



Industrial grade panel, support 7*24 hours of continuous work



Anti image shadow function



Intelligent switch



Built-in rotation



Intelligent temperature control system, double fan design



180 the whole perspective



The image is bright and low power consumption



Multilingual menu operating system

*For details about supported models, see the specifications table

Industry Applications

Video monitoring >

Video surveillance is mainly concentrated in public places and high-risk industries, so there is a higher demand for video surveillance display. In the field of video surveillance, the commercial large screen, with its advantages such as ultra-high definition and ultra-brightness, can make the high-definition monitoring pictures captured by information collection equipment to get the best display, and can carry out automatic alarm or linkage control, providing the best display platform for high-definition monitoring. Fully meet the traffic command, bank monitoring, power dispatch, border monitoring, urban management, community security and other security applications.



< Bank securities

Commercial large-screen displays have also been widely used in the financial industry. Commercial large-screen displays have inherent advantages in the field of public information display by virtue of leading technology, environmental protection, appearance and application. Therefore, they are also favored by customers of financial institutions. With the development of China's financial industry, information technology has been widely used in China's financial field. Terminal display equipment, as an important part of financial informationization, involves a wide range and has a huge procurement scale. It also has particularly important requirements for green environmental protection, technical standards and product quality.

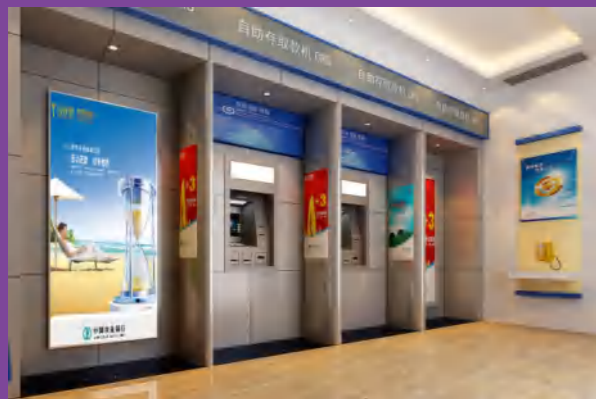

Traders super chain >

Commercial display with advanced display technology, through vivid and vivid pictures, in enhancing the brand or product fashion and sense of science and technology at the same time, tell the brand concept; Moreover, through personalized solutions and the ability to update the display content in time, it has been favored by retail brands and become one of the important means for many fashion brands to add consumer experience.



< Government forces

With the rapid improvement of the global military technology information level, a complete set of monitoring system and corresponding security monitoring equipment are used, together with a high-definition LCD display terminal, to identify the entry and exit of personnel, as well as check posts and sentries. Intelligent perimeter and image monitoring of the area, as well as important warehouse environmental monitoring including (temperature, humidity, smoke, combustible gas, water, infrared detection (illegal invasion), voice alarm) and other functions.

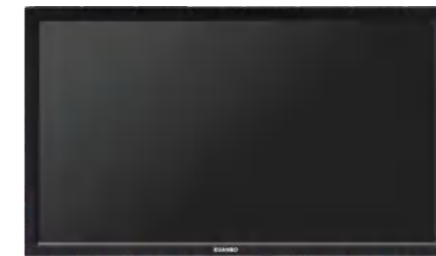

Product Features

- Bilingual menu in Chinese and English, easy to operate, thin and light design, beautiful appearance
- High contrast, high brightness, greatly improve the sense of texture, can better display details
- It has the function of automatically removing residual shadow to protect the long-term use of liquid crystal
- With the latest 3D digital decoding and image noise reduction technology, a variety of digital image correction circuit, image distortion minimum
- I2C bus latest control circuit, image distortion minimum
- Built-in power supply, low energy consumption, LCD screen service life can reach more than 60,000 hours
- Ultra quiet cooling fan design, the whole machine life is longer
- The front frame is all aluminum alloy, which has strong electromagnetic shielding and no radiation

Product Parameters

Model	KB-J650A
Screen size	65"
Product size	1522.8(W)×899(H)×125(D) MM
Display area	1430(W)×804(H) MM
Dot Pitch	0.63(H)×0.63(V) MM
Resolution	1920X1080
Refresh rate	60HZ
Display portion	16:9
Brightness	450cd/m ²
Contrast	5000:1
Color	8 bit, 16.7m
Color temperature	10000K
Viewing angle	178°/178°/178°/178°
Power consumption	260W
Working temperature	0°C ~ 55°C
Working humidity	20~80%
Service life	5 yrs
Power supply	AC 100V~240V~50/60Hz, Universal, ±10%
Input interface	CVBS/S-VIDEO/COMPONENT/HDMI/VGA /DVI/ BNC
Output interface	Composite video 1(2×BNC)/ audio output 1 channel

Dimension

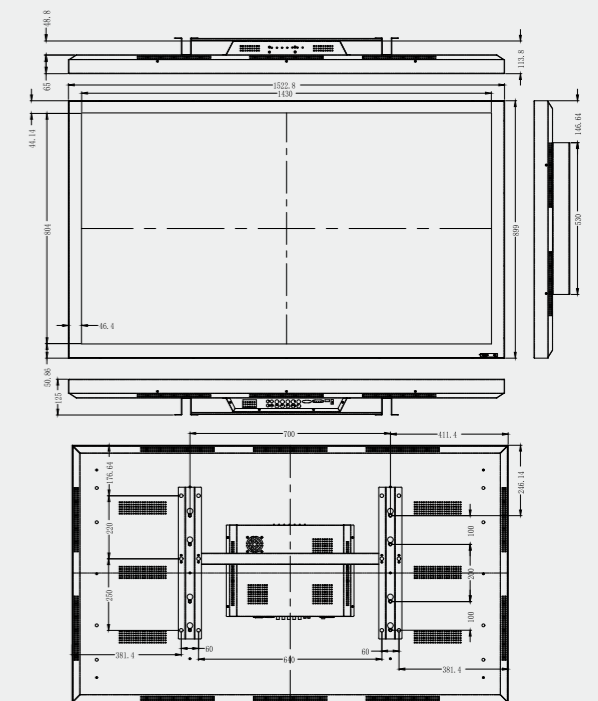

Product Features

- Bilingual menu in Chinese and English, easy to operate, thin and light design, beautiful appearance
- High contrast, high brightness, greatly improve the sense of texture, can better display details
- It has the function of automatically removing residual shadow to protect the long-term use of liquid crystal
- With the latest 3D digital decoding and image noise reduction technology, a variety of digital image correction circuit, image distortion minimum
- I2C bus latest control circuit, image distortion minimum
- Built-in power supply, low energy consumption, LCD screen service life can reach more than 60,000 hours
- Ultra quiet cooling fan design, the whole machine life is longer
- The front frame is all aluminum alloy, which has strong
- electromagnetic shielding and no radiation



Product Parameters

Model	KB-J860A
Screen size	86"
Product size	1958.2(W)×1129.2(H)×95.31(D) MM
Display area	1895.04(W)×1065.96(H) MM
Dot Pitch	0.4935(H)×0.4935(V) MM
Resolution	3840×2160
Refresh rate	120HZ
Display portion	16:9
Brightness	450cd/m ²
Contrast	3000:1
Color	8 bit, 16.7m
Color temperature	10000K
Viewing angle	178°/178°/178°/178°
Power consumption	550W
Working temperature	0°C ~ 40°C
Working humidity	10~90%
Service life	5 yrs
Power supply	AC 100V~240V~50/60Hz,Universal,±10%
Input interface	CVBS/S-VIDEO/COMPONENT/HDMI/VGA /DVI/ BNC
Output interface	Composite video 1(2×BNC)/ audio output 1 channel

Dimension

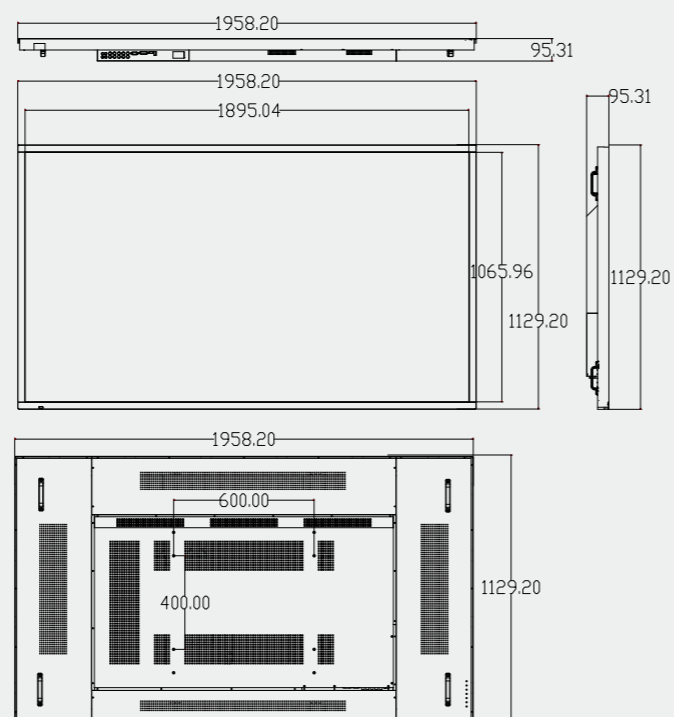

Product Features

- Bilingual menu in Chinese and English, easy to operate, thin and light design, beautiful appearance
- High contrast, high brightness, greatly improve the sense of texture, can better display details
- It has the function of automatically removing residual shadow to protect the long-term use of liquid crystal
- With the latest 3D digital decoding and image noise reduction technology, a variety of digital image correction circuit, image distortion minimum
- I2C bus latest control circuit, image distortion minimum
- Built-in power supply, low energy consumption, LCD screen service life can reach more than 60,000 hours
- Ultra quiet cooling fan design, the whole machine life is longer
- The front frame is all aluminum alloy, which has strong
- electromagnetic shielding and no radiation

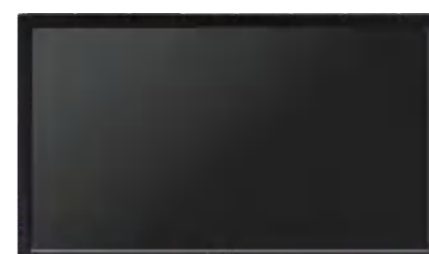

Product Parameters

Model	KB-J980A
Screen size	98"
Product size	2232.71(W)×1288.41(H)×111(D) MM
Display area	2187.8(W)×1242.8(H) MM
Dot Pitch	0.5622(H)×0.5622(V) MM
Resolution	3840×2160
Refresh rate	120HZ
Display portion	16:9
Brightness	500cd/m ²
Contrast	3000:1
Color	8 bit, 16.7m
Color temperature	10000K
Viewing angle	178°/178°/178°/178°
Power consumption	550W
Working temperature	0°C ~ 40°C
Working humidity	10~90%
Service life	5 yrs
Power supply	AC 100V~240V~50/60Hz,Universal,±10%
Input interface	CVBS/S-VIDEO/COMPONENT/HDMI/VGA /DVI/ BNC
Output interface	Composite video 1(2×BNC)/ audio output 1 channel

Dimension

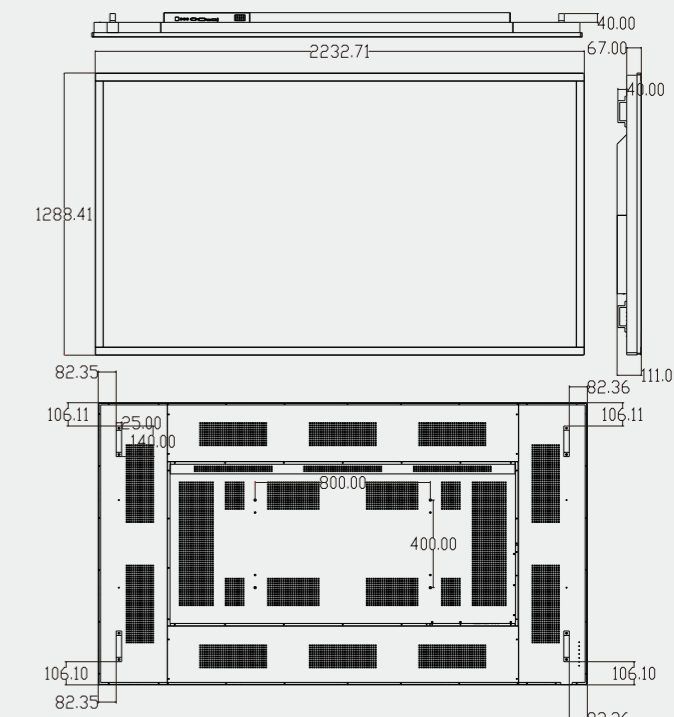

STRETCHED BAR DISPLAY

JP Series

KUANBO DIGITAL SIGNAGE

Stretched LCD Bar Display

JP Series

55'/65'/70'/86'/98'



> FEATURES



Full HD display



Wi-Fi



Intelligent power on/off



Local remote Publishing



Mobile wireless control function



Embedded template calls



USB/SD Card



Mobile Group Management

*For details about supported models, see the specifications table

Industry Applications

Brand chain store >

Everywhere we can see the brand shop was put on a variety of liquid crystal bar screen, from the brand shop of LCD bar screen machine, and then the arrival of the goods on the shelf, the retail industry is more and more strong demand for advertising equipment, at the same time these advertising equipment by showing various types of commodity information, sales information and advertising information, guide the customer consumption and decision-making, efficient conversion for merchants, create considerable profits. Get more traffic. At the same time, it is deeply loved by the majority of merchants with its unique functions, and all major brand stores can use it to advocate product advertising or brand visual presentation.

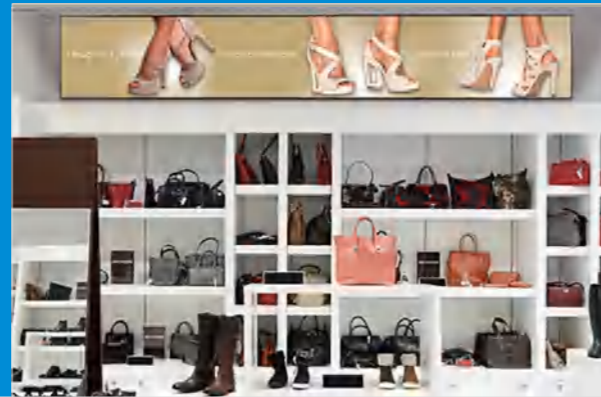

< Science and technology hall

The bar screen perfectly combines pictures, video, text and sound, and has high clarity, high brightness, bright colors, vivid images, simple and lively features. With its unique advantages, it has become a new force in the science and technology pavilion. At the same time, the technology exhibition hall can improve the image of the exhibition hall through the promotion video and picture text dynamic display; Direct visual display of product information, to meet the diversified consumption experience, circular display of exhibition hall product information; The digital scene relieves the pressure of the overall atmosphere and improves the quality of the science and technology pavilion.



Traders super chain >

Supermarket shelf area is very ideal for advertising and promotion, where the LCD bar screen can play its role; Can be used to display commodity advertising, promotional information and membership benefits; The use of bar advertising machine, not only can save the installation space, but also a full range of advertising; The bar screen has the characteristics of high definition and high brightness, which can provide very good display effect in the supermarket lighting environment. While shopping, customers can receive the latest product and service information at the same time, promoting the transaction.



< The airport subway

Transportation industry, such as bus, subway, railway station, subway station and airport and other environments, display dynamic traffic and service information; A variety of installation options, such as lifting, wall mounting or embedded installation; Ultra wide full HD display, high brightness, full viewing angle, stable and reliable; Display vehicle line and vehicle current position; Display bus number information, estimated arrival time and operation status and other convenient information; Can be integrated with the third party system.



Product Features

- Support the advertising machines in the same group can be played synchronously and the synchronization interval is less than 500ms
- Support the mobile phone to remotely set the properties of the advertising player, control the volume, rotation angle, time zone, turn off and turn on the advertising player
- Support real-time management and release on mobile, iPad and PC
- Support remote monitoring of the network status, system status and hardware status of the advertising player, and monitor the content of the advertising player
- Support remote upgrade of advertising player software version and OTA upgrade
- Support the needs of multiple forms of rolling subtitles and bullet screens, the font, size and content of subtitles and bullet screens can be edited
- Scheduling supports multiple recurring modes, recurring by day/week/month
- It can support multiple media such as video/picture/marquee/subtitle/RSS/component/ppt/pdf

Product Parameters

Screen size	15.1
Panel type	a-si TFT active matrix
Display area	374.78mm(H)x64.5mm (V)
Display portion	>3:1 (H:V)
Resolution	1280X235
Display Color	16.7M
Dot Pitch	0.0976(H)x0.2928(V)mm
Brightness	700cd/m ²
Contrast	2000: 1
Viewing angle	89/89/89/89 (Typ.)(CR≥10)
Response time	15ms (Typ.)(Tr+Td)
Refresh rate	60HZ
Input voltage	DC12V2A
Max power consumption	20W
Amplifier	1*1.3W(8Ω)
Certification	3C CE ROHS FCC ISO9000

Dimension

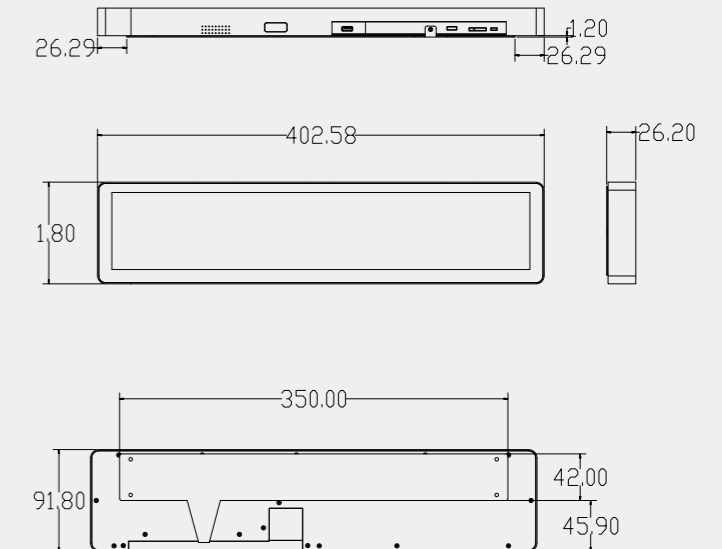

Product Features

- Support the advertising machines in the same group can be played synchronously and the synchronization interval is less than 500ms
- Support the mobile phone to remotely set the properties of the advertising player, control the volume, rotation angle, time zone, turn off and turn on the advertising player
- Support real-time management and release on mobile, iPad and PC
- Support remote monitoring of the network status, system status and hardware status of the advertising player, and monitor the content of the advertising player
- Support remote upgrade of advertising player software version and OTA upgrade
- Support the needs of multiple forms of rolling subtitles and bullet screens, the font, size and content of subtitles and bullet screens can be edited
- Scheduling supports multiple recurring modes, recurring by day/week/month
- It can support multiple media such as video/picture/marquee/subtitle/RSS/component/ppt/pdf



Product Parameters

Screen size	15.3
Panel type	a-si TFT active matrix
Display area	374.78mm(H)x100.138mm (V)
Display portion	>3:1 (H:V)
Resolution	1280X342
Display Color	16.7M
Dot Pitch	0.0976(H)x0.2928(V)mm
Brightness	700cd/m ²
Contrast	1000: 1
Viewing angle	89/89/89/89 (Typ.)(CR≥10)
Response time	8ms (Typ.)(Tr+Td)
Refresh rate	60HZ
Input voltage	AC100V~240V, 50/60Hz
Max power consumption	20W
Amplifier	1*1.3W(8Ω)
Certification	3C CE ROHS FCC ISO9000

Dimension

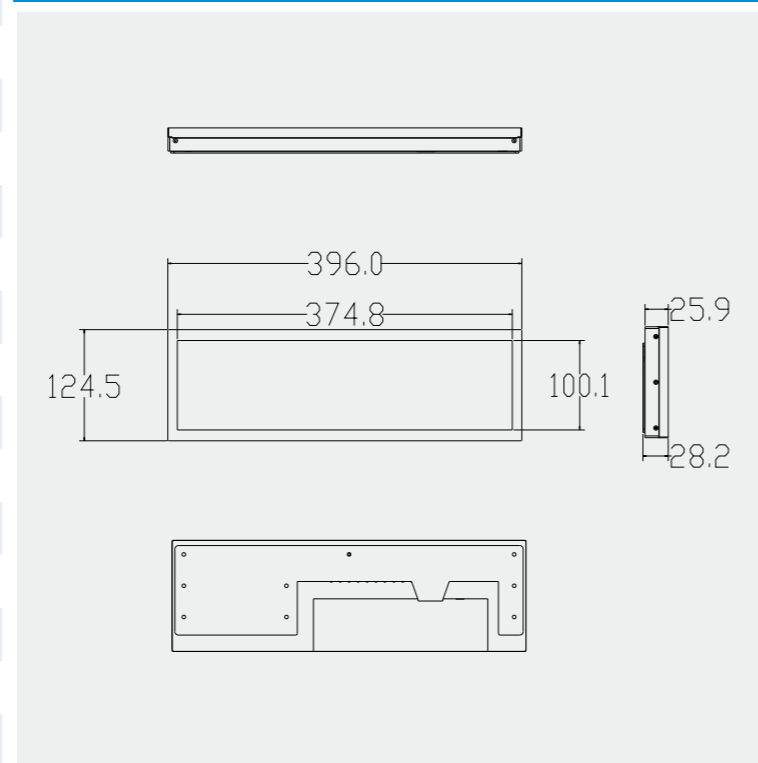

Product Features

- Support the advertising machines in the same group can be played synchronously and the synchronization interval is less than 500ms
- Support the mobile phone to remotely set the properties of the advertising player, control the volume, rotation angle, time zone, turn off and turn on the advertising player
- Support real-time management and release on mobile, iPad and PC
- Support remote monitoring of the network status, system status and hardware status of the advertising player, and monitor the content of the advertising player
- Support remote upgrade of advertising player software version and OTA upgrade
- Support the needs of multiple forms of rolling subtitles and bullet screens, the font, size and content of subtitles and bullet screens can be edited
- Scheduling supports multiple recurring modes, recurring by day/week/month
- It can support multiple media such as video/picture/marquee/subtitle/RSS/component/ppt/pdf



Product Parameters

Screen size	23.6
Panel type	a-si TFT active matrix
Display area	597.89mm(H)x66.6mm (V)
Display portion	>3:1 (H:V)
Resolution	1920X213
Display Color	16.7M
Dot Pitch	0.1038(H)x0.3114(V)mm
Brightness	700cd/m ²
Contrast	1200: 1
Viewing angle	89/89/89/89 (Typ.)(CR≥10)
Response time	30ms (Typ.)(Tr+Td)
Refresh rate	60HZ
Input voltage	DC12V2A
Max power consumption	20W
Amplifier	1*1.3W(8Ω)
Certification	3C CE ROHS FCC ISO9000

Dimension

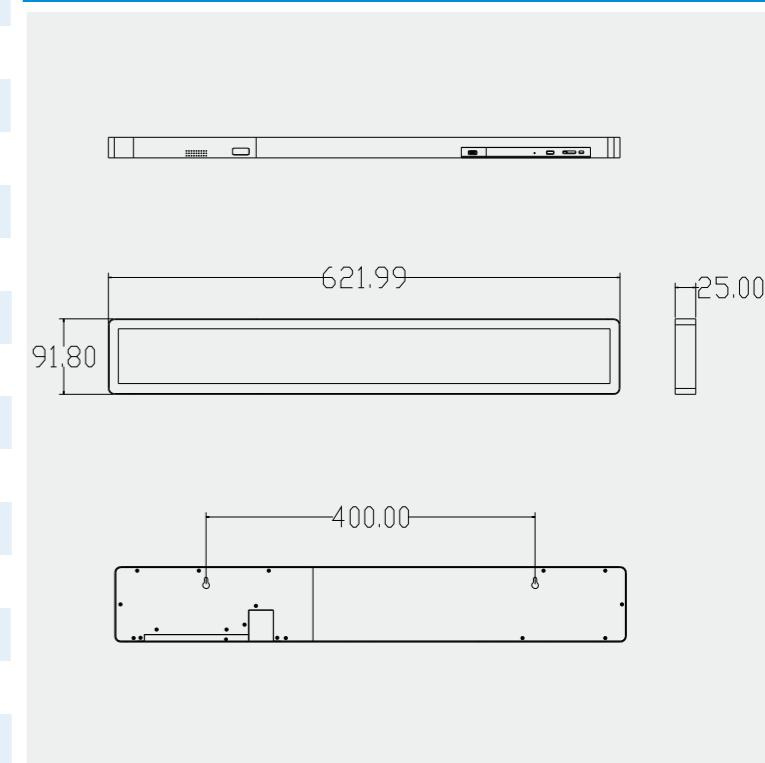

Product Features

- Support the advertising machines in the same group can be played synchronously and the synchronization interval is less than 500ms
- Support the mobile phone to remotely set the properties of the advertising player, control the volume, rotation angle, time zone, turn off and turn on the advertising player
- Support real-time management and release on mobile, iPad and PC
- Support remote monitoring of the network status, system status and hardware status of the advertising player, and monitor the content of the advertising player
- Support remote upgrade of advertising player software version and OTA upgrade
- Support the needs of multiple forms of rolling subtitles and bullet screens, the font, size and content of subtitles and bullet screens can be edited
- Scheduling supports multiple recurring modes, recurring by day/week/month
- It can support multiple media such as video/picture/marquee/subtitle/RSS/component/ppt/pdf

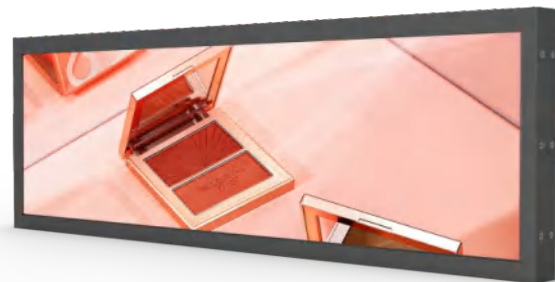

Product Parameters

Screen size	21.2
Panel type	a-si TFT active matrix
Display area	518mm(H)x148mm (V)
Display portion	>3:1 (H:V)
Resolution	1920X550
Display Color	16.7M
Dot Pitch	0.090(H)x0.270(V)mm
Brightness	500cd/m ²
Contrast	1000: 1
Viewing angle	89/89/89/89 (Typ.)(CR≥10)
Response time	14ms (Typ.)(Tr+Td)
Refresh rate	60HZ
Input voltage	AC100V~240V, 50/60Hz
Max power consumption	20W
Amplifier	1*1.3W(8Ω)
Certification	3C CE ROHS FCC ISO9000

Dimension

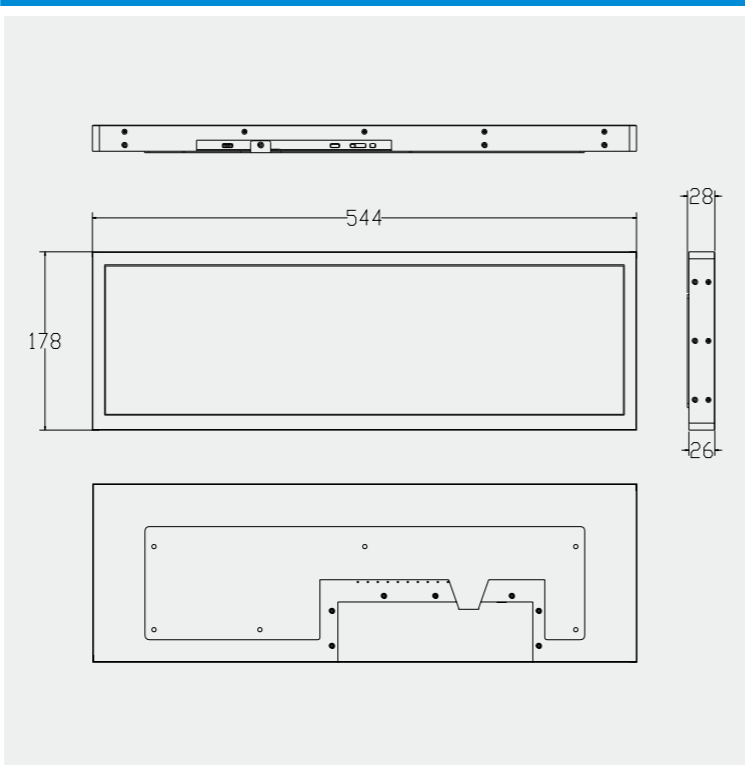

Product Features

- Support the advertising machines in the same group can be played synchronously and the synchronization interval is less than 500ms
- Support the mobile phone to remotely set the properties of the advertising player, control the volume, rotation angle, time zone, turn off and turn on the advertising player
- Support real-time management and release on mobile, iPad and PC
- Support remote monitoring of the network status, system status and hardware status of the advertising player, and monitor the content of the advertising player
- Support remote upgrade of advertising player software version and OTA upgrade
- Support the needs of multiple forms of rolling subtitles and bullet screens, the font, size and content of subtitles and bullet screens can be edited
- Scheduling supports multiple recurring modes, recurring by day/week/month
- It can support multiple media such as video/picture/marquee/subtitle/RSS/component/ppt/pdf



Product Parameters

Model	23.1
CPU	High-performance single-chip quad-core Cortex-A35
DDR	1G DDR3
FLASH	8GB / 16GB EMMC
Graphics card	23.1, Innolux S231AJ1 TFT LCD158*1920
TF card	Support TF card extension, support multimedia playback
USB	Offers 3 USB 2.0 ports for connecting to computers as soft Upgrade interface and usb flash drive, camera, TP and other peripheral expansion
Power input	DC 12V/2A power input, type-c port
	standby <0.5W
Languages	Chinese English
WIFI	2.4G

Dimension

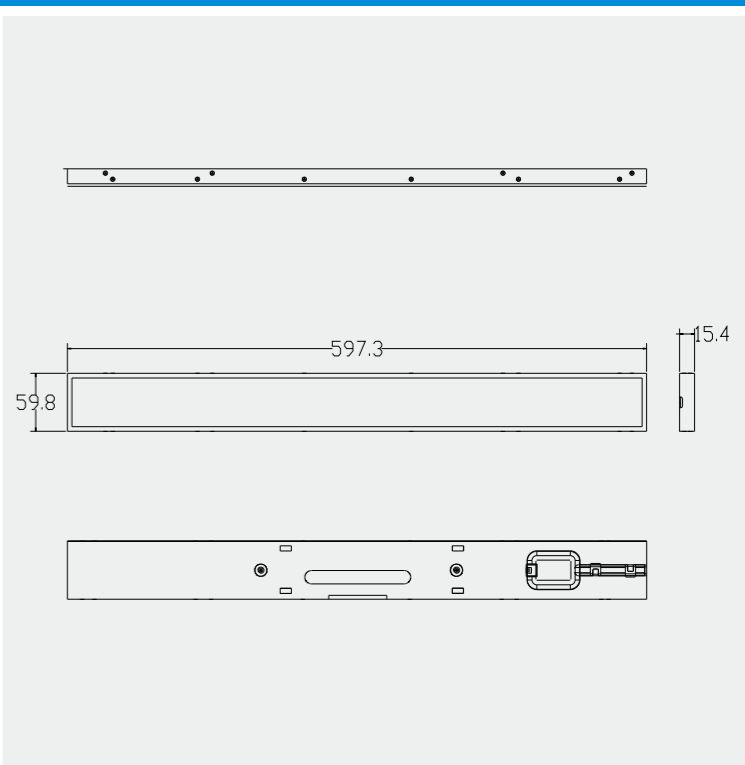

Customized Products Industry Applications



Marble capacitive touch all-in-one machine



Solid wood capacitor touch table



Marble infrared office machine



Self-service terminal service All-in-one



Poster advertising machine



wall-mounted advertising machine



Hanging advertising machine



Horizontal touch query all-in-one machine

KUANBO DIGITAL SIGNAGE

Customization

XA Series

22'/32'/42'/55'/65'/70'/84'/86'/98'



> FEATURES



Beautiful appearance



High safety



Good scalability can be customized



Stable performance



Simple maintenance



Flexibly add software function modules

*For details about supported models, see the specifications table

DISTRIBUTED PROCESSOR

FB Series

HD distributed business display system is an intelligent layout and release business management display system, safe and reliable playback terminal, Flexible management platform, to solve the new retail industry fast layout, Rapid release of the needs of intelligent face recognition can achieve orientation Release, precision marketing.

Distributed plug-in upgrade version



Distributed premium serverless version



Distributed OPS upgrade version



KUANBO DIGITAL SIGNATE

Distributed Processor

FB Series

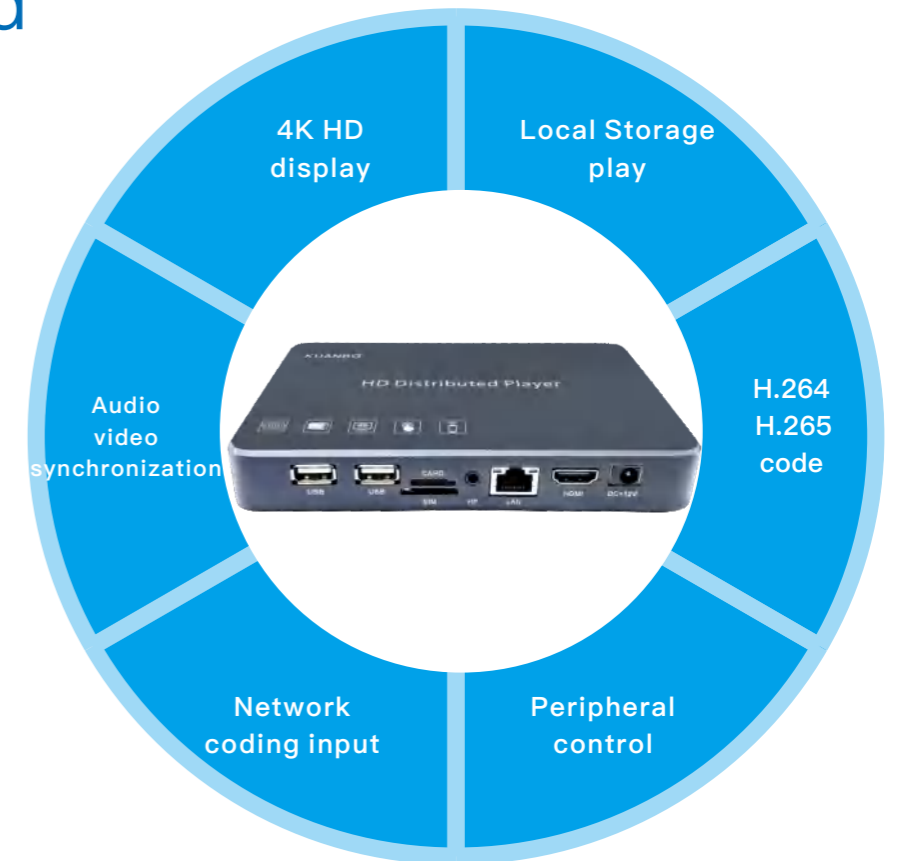

> FEATURES

- 360° Rotation and splicing randomly
- Arbitrary splicing of multiple display terminals
- Mobile IPAD control management
- 4K HD peer-to-peer playback
- H264/H265 Code access
- Extended access to peripherals

*For details about supported models, see the specifications table

Customized Products Industry Applications

Restaurant chain >

Roots with + Internet, more and more traditional industries through Internet publishing system transfer the brand value, high-definition digital information publishing system that diners intuitive understanding of the food from material selection to cooking, and then to the whole process of the table, the joining together of diversified plastic, rich in playback mode, enough to attract the attention of customers and steps.



< enterprise

Through the network unified management of the whole enterprise and even the whole building up to dozens of to hundreds of publishing terminals, one-click publishing, intelligent typesetting, advanced management and other functions to bring convenient operation experience, unified control of split-screen, single screen, LED screen, touch screen, bar screen and other display terminals, Widely used in enterprises and institutions, large state-owned enterprises, group companies and other corporate image display.

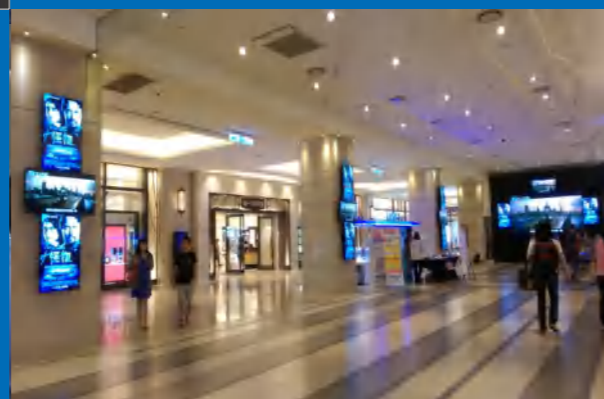

Shopping malls supermarkets >

The tide of rapid development in digital, businesses use the venue of the existing resources, to join the ever-changing business display terminal, bring consumer technology feels dye-in-the-wood dynamic test, man-machine interactive mode, which can realize online shopping experience, facial recognition technology, can release its consumers by identifying facial orientation needed goods, increase the interactivity and entertaining. The distributed display system based on Internet is an essential high-tech display system for shopping malls.

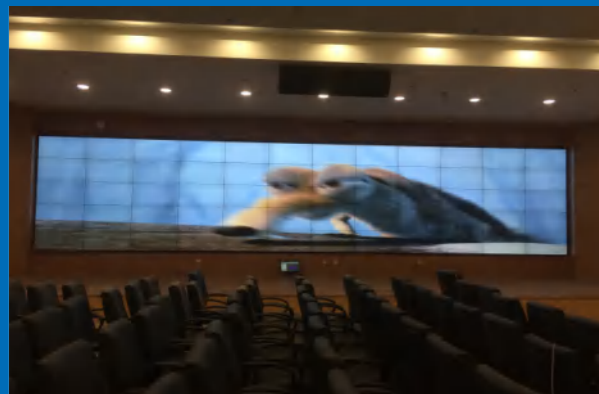

< Large conference hall

With the progress of science and technology, the large conference room of all large companies can undertake academic report, hd video playback, combined with customer demand, this system not only can support hd 4 k, 8 k hd video playback, you can also use mobile phones or the scroll, PPT material select, suspension of video playback, and other functions.

KUANBO DIGITAL SIGNATE



Model	KB-FB1000
CPU processor	frequency 1.8GHz A17 four core, Mali-T764
Memory	standard 2G (4G optional)
Built-in storage	standard 8G (16G/32G/64G optional)
Built-in ROM	2KB EEPROM
External device interface	x1 HDMI/ x1 VGA.0 /x1 EDP/1 serial port /x6 USB2.0/ x2 GPIO /x1 AUDIO /x1 Gigabit network x1 MSATA extent/TF card support
The clock	RTC real-time clock, timing switch
Power supply	12V/ 3A
Working humidity	10% ~ 90% @40oC(No condensation) metal
The material	metal

Model	KB-FB2000
CPU processor	frequency 1.8GHz A17 four core, Mali-T764
Memory	standard 2G (4G optional)
Built-in storage	standard 8G (16G/32G/64G optional)
Built-in ROM	2KB EEPROM
External device interface	x1 HDMI/ x1 VGA.0 /x1 EDP/1 serial port /x6 USB2.0 x2 GPIO /x1 AUDIO /x1 Gigabit network x1 MSATA extent/TF card support
The clock	RTC real-time clock, timing switch
Power supply	12V/ 3A
Working humidity	10% ~ 90% @40oC(No condensation) metal
The material	metal
Size	180x120x30mm(W x H x D)



Model	KB-TV400
Video input	x1 HDMI
Input resolution	1080p\1080i\720p
Audio input	x1 HDMI built-in audio, x1 3.5 Analog audio
Video coding	H.264 Baseline Profile/Main Profile/High Profile optional
Coding frame rate	5-60 adjustable
Post-coding resolution	1920x1080/1280x720/1024x576/960x540/850x480 720x576 720x540/720x480/640x480/352x480 352x228/320x240/
Rate control	CBR/VBR optional
Network	IP set up, x1 MB net
Network protocol	TS/HLS/RTSP/FLV/RTMP/
Configuration management	Web, upgrade, factory data reset
The power supply	12V/DC 2A
Operating temperature/humidity	-10°C to 50°C /<90%, No condensation
Size	8cmx10.7cmx3cm

Distributed System Topology Solution

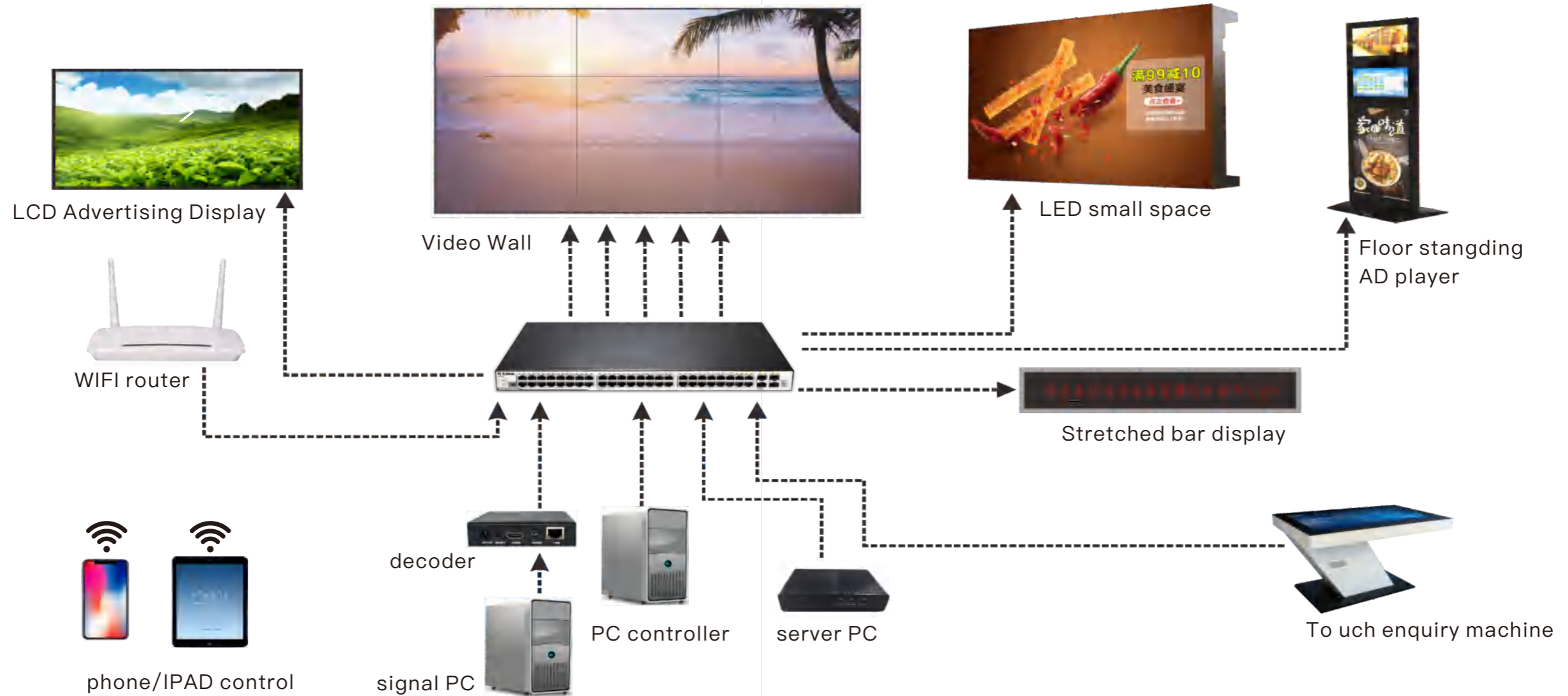

Model	KB-1001
Processor	Intel @i3-7100U 2.4GHz CPU
Memory	4G DDR3
Hard disk	64GB SSD
External device interface	x4 USB 3.0 / x2 USB 2.0 /x1 HDMI
Power supply	x1 VGA /x1 AUDIO /x1 Gigabit network x1 DC-12V input / 100-240V
Working temperature	0°C to 45°C
Working humidity	95% @40°C, No condensation
Size	175X128X37MM
Operating system	Linux



Model	KB-1000S
Processor	Intel super E3-1220v6
Memory	16G DDR3
RAID	Raid 0/1/10/5
Hard disk	x2 240GB SSD
Network card	Intel dual @i210-AT Ethernet controller
I/O expansion slot	1 x PCIE 3.0 x 16 slot
External device interface	x2 USB 3.0 / x2 USB 2.0 /x1 VGA / 1个Channeling mouth /1个R45 Gigabit network/x1 R45/
Power supply	1 200W Low noise AC power supply continues to supply power
Working temperature	10°C to 35°C
Working humidity	8%-90%, No condensation
Size	43 x 437 x 287 mm
Operating system	Windows 10 Pro/Linux



Engineering application case



Garment industry

Provide users with intuitive, vivid information, including the new season, clothing matching, discount products, news and so on, not only enhance the overall store image, create a new, eye-catching creative demonstration.

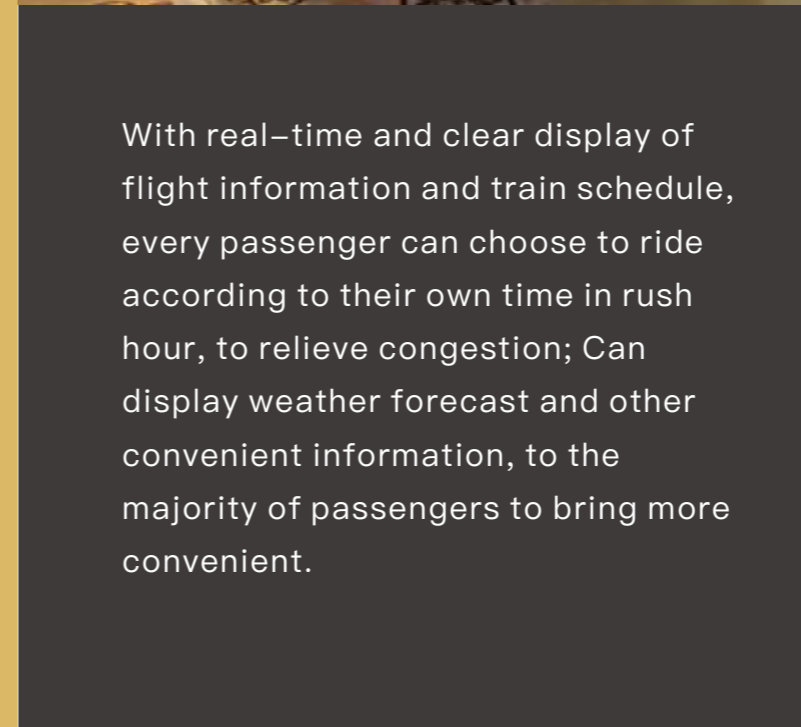

The transportation

With real-time and clear display of flight information and train schedule, every passenger can choose to ride according to their own time in rush hour, to relieve congestion; Can display weather forecast and other convenient information, to the majority of passengers to bring more convenient.



Show case

KUANBO splicing system with excellent definition, color, seam, weather resistance and other characteristics, in large museums, science and technology museum, auditorium, command center, real estate and other projects have been widely used.



Power grid management

In order to facilitate management, the network management center of communication operators can apply the spliced wall display system to provide comprehensive management and high-definition large-scale display for the operation of multiple networks, so that it has a highly intelligent control system that is easy to operate.



The entertainment

Kuanbo innovated from the structural components of products, combined with traditional office furniture structures such as tea tables, tables and display tables, and perfectly integrated the multi-touch interactive platform, which made a subversive change in its functional application.

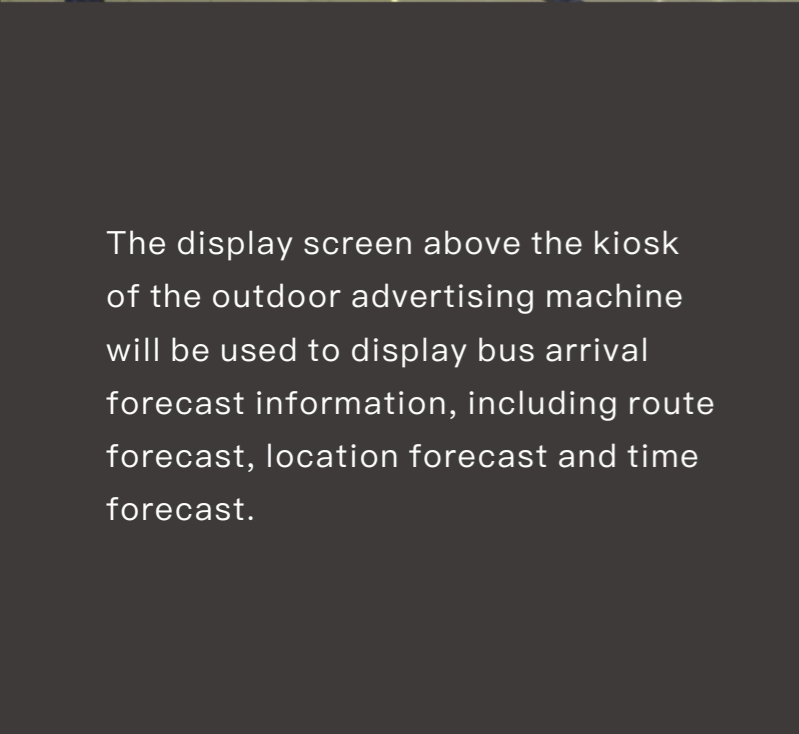

The bus station

The display screen above the kiosk of the outdoor advertising machine will be used to display bus arrival forecast information, including route forecast, location forecast and time forecast.



It can display animation, video, 3D panorama, picture, music, text and other digital resources, and display all kinds of 3D real estate, real estate structure, real estate 3D map and other information through LCD Mosaic large screen in a vivid and dynamic way. It can give viewing information home buyers with a strong visual impact.



Real estate



The mall management

Mall operators can use the spliced wall display system to monitor and manage the mall in real time, such as the view of management personnel, anti-theft and loss prevention of on-site items, customer flow statistics, work efficiency, etc., are all major problems.



Smart banking

KUANBO touch display all-in-one machine has realized the direct and friendly interaction between customers and equipment. It can provide more than 90% of personal business such as inquiry, card registration, electronic banking, financial management, precious metals, etc. Through the intuitive screen of touch display equipment, simple operation and fast

Qualification certificate

