



# Service Manual

## **Generator Set**

**Onan Generator Set for Home Standby**

C13N6H (Spec A)

C17N6H (Spec A)

C20N6H (Spec A)

C20N6HC (Spec A)

**CALIFORNIA  
Proposition 65**

**Warning: Natural Gas/Liquid Propane Gas engine exhaust and some of its constituents are known to the State of California to cause cancer, birth defects, and other reproductive harm.**

# Table of Contents

---

1. IMPORTANT SAFETY INSTRUCTIONS .....	1
1.1 Warning, Caution, and Note Styles Used in This Manual .....	1
1.2 General Information .....	1
1.3 Generator Set Safety Code .....	4
1.4 Electrical Shocks and Arc Flashes Can Cause Severe Personal Injury or Death.....	6
1.5 Fuel and Fumes Are Flammable .....	7
1.6 Exhaust Gases Are Deadly.....	8
1.7 The Hazards of Carbon Monoxide.....	9
1.8 Earth Ground Connection .....	10
2. INTRODUCTION.....	11
2.1 About This Manual.....	11
2.2 Test Equipment.....	12
2.3 Schedule of Abbreviations .....	12
2.4 Related Literature .....	14
2.5 Model Specifications .....	15
2.6 After Sales Services.....	18
3. STARTUP .....	25
3.1 "Establishing Communications" Message .....	25
3.2 "Clock Setup" Screen.....	25
3.3 "Exercise" Screen .....	31
3.4 "Brightness and Contrast" Screen .....	34
3.5 "About" Screen.....	36
3.6 "Event Log" Screen.....	38
3.7 "Fault Log" Screen .....	39
3.8 "System Status" Screen.....	40
3.9 "Mode" Screen.....	41
3.10 Automatic Load Management.....	44
3.11 Startup .....	44
4. OPERATION .....	47
4.1 Introduction .....	47
4.2 General Operating Conditions .....	47
4.3 Generator Set Operation.....	47
4.4 Manual Start Sequence (Local) .....	53
4.5 Manual Stop Sequence (Local) .....	54
4.6 Manual Start/Stop Sequence (Remote).....	54
4.7 "Fault" and "New Event" Screens .....	54
5. MAINTENANCE .....	59
5.1 Maintenance Safety .....	59
5.2 Periodic Maintenance .....	63

---

5.3 Engine Oil .....	65
5.4 Exhaust System Maintenance .....	72
5.5 DC Electrical System .....	73
5.6 Batteries.....	73
5.7 Spark Plugs .....	77
5.8 Cleaning the Generator Set Housing.....	77
5.9 Complete System Test .....	77
6. SERVICE.....	79
6.1 Control System .....	79
6.2 Fuel System.....	88
6.3 Cylinder Head Assembly Replacement .....	96
6.4 Engine Exhaust.....	99
6.5 Alternator .....	100
6.6 Placing the Generator Set Back in Service .....	119
6.7 Transfer Switch.....	119
6.8 Line Circuit Breaker Troubleshooting .....	120
7. TROUBLESHOOTING .....	121
7.1 Troubleshooting Procedures.....	121
7.2 Safety Considerations.....	121
7.3 GATRR Troubleshooting Approach .....	122
7.4 Tools and Parts Required .....	123
7.5 Troubleshooting with the Local or Remote Displays .....	124
7.6 Utility-Powered Battery Charger Troubleshooting .....	124
7.7 Engine Flywheel Battery Charger Troubleshooting .....	127
7.8 Fuel Shutoff Solenoid Valve .....	129
7.9 Troubleshooting by Symptom .....	130
7.10 Troubleshooting with Fault Codes .....	134
7.11 Remote Monitoring Communication Troubleshooting.....	157
APPENDIX A. WIRING DIAGRAMS .....	165
A.0 Wiring Diagrams .....	166

# 1 IMPORTANT SAFETY INSTRUCTIONS

---

SAVE THESE INSTRUCTIONS. This manual contains important instructions that should be followed during installation and maintenance of the generator set and batteries.

Safe and efficient operation can be achieved only if the equipment is properly operated and maintained. Many accidents are caused by failure to follow fundamental rules and precautions.

## 1.1 Warning, Caution, and Note Styles Used in This Manual

The following safety styles and symbols found throughout this manual indicate potentially hazardous conditions to the operator, service personnel, or equipment.

### DANGER

*Indicates a hazardous situation that, if not avoided, will result in death or serious injury.*

### WARNING

*Indicates a hazardous situation that, if not avoided, could result in death or serious injury.*

### CAUTION

*Indicates a hazardous situation that, if not avoided, could result in minor or moderate injury.*

### NOTICE

Indicates information considered important, but not hazard-related (e.g., messages relating to property damage).

## 1.2 General Information

This manual should form part of the documentation package supplied by Cummins with specific generator sets. In the event that this manual has been supplied in isolation please contact your authorized distributor.

### NOTICE

**It is in the operator's interest to read and understand all warnings and cautions contained within the documentation relevant to the generator set, its operation and daily maintenance.**

## General Safety Precautions

### WARNING

#### ***Hot Pressurized Liquid***

***Contact with hot liquid can cause severe burns.***

***Do not open the pressure cap while the engine is running. Let the engine cool down before removing the cap. Turn the cap slowly and do not open it fully until the pressure has been relieved.***

### WARNING

#### ***Moving Parts***

***Moving parts can cause severe personal injury.***

***Use extreme caution around moving parts. All guards must be properly fastened to prevent unintended contact.***

### WARNING

#### ***Toxic Hazard***

***Used engine oils have been identified by some state and federal agencies to cause cancer or reproductive toxicity.***

***Do not ingest, breathe the fumes, or contact used oil when checking or changing engine oil. Wear protective gloves and face guard.***

### WARNING

#### ***Electrical Generating Equipment***

***Incorrect operation and maintenance can result in severe personal injury or death.***

***Do not operate equipment when fatigued, or after consuming any alcohol or drug.***

***Make sure that only suitably trained and experienced service personnel perform electrical and/or mechanical service.***

### WARNING

#### ***Toxic Gases***

***Substances in exhaust gases have been identified by some state and federal agencies to cause cancer or reproductive toxicity.***

***Do not breathe in or come into contact with exhaust gases.***

### WARNING

#### ***High Noise Level***

***Generator sets in operation emit noise, which can cause hearing damage.***

***Wear appropriate ear protection at all times.***

**⚠ WARNING****Hot Surfaces**

**Contact with hot surfaces can cause severe burns.**

**The unit is to be installed so that the risk of hot surface contact by people is minimized. Wear appropriate PPE when working on hot equipment and avoid contact with hot surfaces.**

**⚠ WARNING****Toxic Hazard**

**Ethylene glycol, used as an engine coolant, is toxic to humans and animals.**

**Wear appropriate PPE. Clean up coolant spills and dispose of used coolant in accordance with local environmental regulations.**

**⚠ WARNING****Combustible Liquid**

**Ignition of combustible liquids is a fire or explosion hazard which can cause severe burns or death.**

**Do not store fuel, cleaners, oil, etc., near the generator set. Do not use combustible liquids like ether.**

**⚠ WARNING****Combustible Gases**

**Generator sets in operation have combustible gases under pressure, which if ignited can cause eye and ear damage.**

**Wear appropriate eye and ear protection at all times.**

**⚠ WARNING****Combustible Gases**

**Generator sets in operation have combustible gases under pressure, which if ignited can cause severe injury.**

**Do not operate the generator set with any doors open.**

**⚠ WARNING****Fire Hazard**

**Materials drawn into the generator set, as well as accumulated grease and oil, are a fire hazard. Fire can cause severe burns or death.**

**Keep the generator set and the surrounding area clean and free from obstructions. Make sure the generator set is mounted in a manner to prevent combustible materials from accumulating under the unit.**

**⚠ WARNING*****Automated Machinery***

***Accidental or remote starting of the generator set can cause severe personal injury or death.***

***Isolate all auxiliary supplies and use an insulated wrench to disconnect the starting battery cables (negative [-] first).***

**NOTICE**

**Keep multi-type ABC fire extinguishers close by. Class A fires involve ordinary combustible materials such as wood and cloth. Class B fires involve combustible and flammable liquid fuels and gaseous fuels. Class C fires involve live electrical equipment. (Refer to NFPA No. 10 in the applicable region.)**

**NOTICE**

**Before performing maintenance and service procedures on enclosed generator sets, make sure the service access doors are secured open.**

**NOTICE**

**Stepping on the generator set can cause parts to bend or break, leading to electrical shorts, or to fuel, coolant, or exhaust leaks. Do not step on the generator set when entering or leaving the generator set room.**

## 1.3 Generator Set Safety Code

Before operating the generator set, read the manuals and become familiar with them and the equipment. Safe and efficient operation can be achieved only if the equipment is properly operated and maintained. Many accidents are caused by failure to follow fundamental rules and precautions.

**⚠ WARNING*****Electrical Generating Equipment***

***Incorrect operation and maintenance can result in severe personal injury or death.***

***Read and follow all Safety Precautions, Warnings, and Cautions throughout this manual and the documentation supplied with the generator set.***

### **Moving Parts Can Cause Severe Personal Injury or Death**

- Keep hands, clothing, and jewelry away from moving parts.
- Before starting work on the generator set, disconnect the battery charger from its AC source, then disconnect the starting batteries using an insulated wrench, negative (-) cable first. This will prevent accidental starting.



- Make sure that fasteners on the generator set are secure. Tighten supports and clamps; keep guards in position over fans, drive belts, etc.
- Do not wear loose clothing or jewelry in the vicinity of moving parts or while working on electrical equipment. Loose clothing and jewelry can become caught in moving parts.
- If any adjustments must be made while the unit is running, use extreme caution around hot manifolds, moving parts, etc.

## Alternator Operating Areas

### WARNING

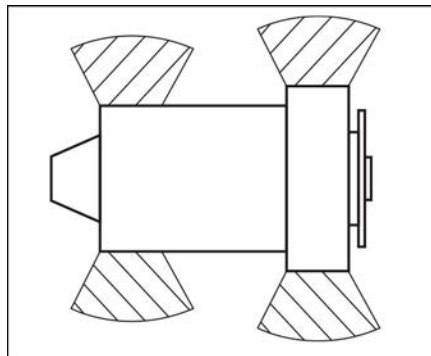
#### ***Ejected Debris***

***Debris ejected during catastrophic failure can cause serious injury or death by impact, severing or stabbing.***

***To prevent injury:***

- ***Keep away from the air inlet and air outlet when the alternator is running.***
- ***Do not put operator controls near the air inlet and air outlet.***
- ***Do not cause overheating by running the alternator outside rating plate parameters.***
- ***Do not overload the alternator.***
- ***Do not run an alternator with excessive vibration.***
- ***Do not synchronize parallel alternators outside the specified parameters.***

Always wear suitable PPE when working in the hatched areas shown in the diagram or directly in-line with any air inlet/outlet.



**FIGURE 1. HATCHED AREAS**

Make sure this consideration is captured in your risk assessment.

## 1.4 Electrical Shocks and Arc Flashes Can Cause Severe Personal Injury or Death

### WARNING

#### ***Electric Shock Hazard***

***Voltages and currents present an electrical shock hazard that can cause severe burns or death.***

***Contact with exposed energized circuits with potentials of 50 Volts AC or 75 Volts DC or higher can cause electrical shock and electrical arc flash. Refer to standard NFPA 70E or equivalent safety standards in corresponding regions for details of the dangers involved and for the safety requirements.***

Guidelines to follow when working on de-energized electrical systems:

- Use proper PPE. Do not wear jewelry and make sure that any conductive items are removed from pockets as these items can fall into equipment and the resulting short circuit can cause shock or burning. Refer to standard NFPA 70E for PPE standards.
- De-energize and lockout/tagout electrical systems prior to working on them. Lockout/Tagout is intended to prevent injury due to unexpected start-up of equipment or the release of stored energy. Please refer to the lockout/tagout section for more information.
- De-energize and lockout/tagout all circuits and devices before removing any protective shields or making any measurements on electrical equipment.
- Follow all applicable regional electrical and safety codes.

Guidelines to follow when working on energized electrical systems:

### NOTICE

**It is the policy of Cummins Inc. to perform all electrical work in a de-energized state. However, employees or suppliers may be permitted to occasionally perform work on energized electrical equipment only when qualified and authorized to do so and when troubleshooting, or if de-energizing the equipment would create a greater risk or make the task impossible and all other alternatives have been exhausted.**

### NOTICE

**Exposed energized electrical work is only allowed as per the relevant procedures and must be undertaken by a Cummins authorized person with any appropriate energized work permit for the work to be performed while using proper PPE, tools and equipment.**

In summary:

- Do not tamper with or bypass interlocks unless you are authorized to do so.

- Understand and assess the risks - use proper PPE. Do not wear jewelry and make sure that any conductive items are removed from pockets as these items can fall into equipment and the resulting short circuit can cause shock or burning. Refer to standard NFPA 70E for PPE standards.
- Make sure that an accompanying person who can undertake a rescue is nearby.

## AC Supply and Isolation

### NOTICE

**Local electrical codes and regulations (for example, *BS EN 12601:2010 Reciprocating internal combustion engine driven generating sets*) may require the installation of a disconnect means for the generator set, either on the generator set or where the generator set conductors enter a facility.**

### NOTICE

**The AC supply must have the correct over current and earth fault protection according to local electrical codes and regulations. This equipment must be earthed (grounded).**

It is the sole responsibility of the customer to provide AC power conductors for connection to load devices and the means to isolate the AC input to the terminal box; these must comply with local electrical codes and regulations. Refer to the wiring diagram supplied with the generator set.

The disconnecting device is not provided as part of the generator set, and Cummins accepts no responsibility for providing the means of isolation.

## AC Disconnect Sources

### WARNING

#### ***Hazardous Voltage***

***Contact with high voltages can cause severe electrical shock, burns, or death.***

***The equipment may have more than one source of electrical energy. Disconnecting one source without disconnecting the others presents a shock hazard. Before starting work, disconnect the equipment, and verify that all sources of electrical energy have been removed.***

## 1.5 Fuel and Fumes Are Flammable

Fire, explosion, and personal injury or death can result from improper practices.

- Do not fill fuel tanks while the engine is running unless the tanks are outside the engine compartment. Fuel contact with hot engine or exhaust is a potential fire hazard.

- Do not permit any flame, cigarette, pilot light, spark, arcing equipment, or other ignition source near the generator set or fuel tank.
- Fuel lines must be adequately secured and free of leaks. Fuel connection at the engine should be made with an approved flexible line. Do not use copper piping on flexible lines as copper will become brittle if continuously vibrated or repeatedly bent.
- Make sure all fuel supplies have a positive shutoff valve.
- Make sure the battery area has been well-ventilated prior to servicing near it. Lead-acid batteries emit a highly explosive hydrogen gas that can be ignited by arcing, sparking, smoking, etc.

## Gaseous Fuels

Natural gas is lighter than air, and will tend to gather under covered areas. Propane is heavier than air, and will tend to gather in sumps or low areas. NFPA code requires all persons handling propane to be trained and qualified.

## Do Not Operate in Flammable and Explosive Environments

Flammable vapor can cause an engine to over speed and become difficult to stop, resulting in possible fire, explosion, severe personal injury, and death. Do not operate a generator set where a flammable vapor environment can be created, unless the generator set is equipped with an automatic safety device to block the air intake and stop the engine. The owners and operators of the generator set are solely responsible for operating the generator set safely. Contact your authorized Cummins distributor for more information.

## 1.6 Exhaust Gases Are Deadly

- Provide an adequate exhaust system to properly expel discharged gases away from enclosed or sheltered areas, and areas where individuals are likely to congregate. Visually and audibly inspect the exhaust system daily for leaks per the maintenance schedule. Make sure that exhaust manifolds are secured and not warped. Do not use exhaust gases to heat a compartment.
- Make sure the unit is well ventilated.

## Exhaust Precautions

 **WARNING**

***Hot Exhaust Gases***

***Contact with hot exhaust gases can cause severe burns.***

***Wear personal protective equipment when working on equipment.***

**⚠ WARNING****Hot Surfaces**

**Contact with hot surfaces can cause severe burns.**

**The unit is to be installed so that the risk of hot surface contact by people is minimized. Wear appropriate PPE when working on hot equipment and avoid contact with hot surfaces.**

**⚠ WARNING****Toxic Gases**

**Inhalation of exhaust gases can cause asphyxiation and death.**

**Pipe exhaust gas outside and away from windows, doors, or other inlets to buildings. Do not allow exhaust gas to accumulate in habitable areas.**

**⚠ WARNING****Fire Hazard**

**Contaminated insulation is a fire hazard. Fire can cause severe burns or death.**

**Remove any contaminated insulation and dispose of it in accordance with local regulations.**

The exhaust outlet may be sited at the top or bottom of the generator set. Make sure that the exhaust outlet is not obstructed. Personnel using this equipment must be made aware of the exhaust position. Position the exhaust away from flammable materials - in the case of exhaust outlets at the bottom, make sure that vegetation is removed from the vicinity of the exhaust.

The exhaust pipes may have some insulating covers fitted. If these covers become contaminated they must be replaced before the generator set is run.

To minimize the risk of fire, make sure the following steps are observed:

- Make sure that the engine is allowed to cool thoroughly before performing maintenance or operation tasks.
- Clean the exhaust pipe thoroughly.

## 1.7 The Hazards of Carbon Monoxide

Carbon monoxide (CO) is an odorless, colorless, tasteless and non-irritating gas. You cannot see it or smell it. Red blood cells, however, have a greater affinity for CO than for oxygen. Therefore, exposure even to low levels of CO for a prolonged period can lead to asphyxiation (lack of oxygen) resulting in death. Mild effects of CO poisoning include eye irritation, dizziness, headaches, fatigue and the inability to think clearly. More extreme symptoms include vomiting, seizures and collapse.

Engine-driven generator sets produce harmful levels of carbon monoxide that can injure or kill you.

## Special Risks of CO near the Home

### WARNING

#### **Toxic Gases**

***Carbon monoxide (CO) gas can cause nausea, fainting, or death. Residents can be exposed to lethal levels of CO when the generator set is running. Depending on air temperature and wind, CO can accumulate in or near the home.***

***To protect yourself and others from the dangers of CO poisoning, it is recommended that reliable, approved, and operable CO detector alarms are installed in proper locations in the home as specified by their manufacturer.***

## Protecting Yourself from CO Poisoning

- Locate the generator set in an area where there are no windows, doors, or other access points into the home.
- Make sure all CO detectors are installed and working properly.
- Pay attention for signs of CO poisoning.
- Check the exhaust system for corrosion, obstruction, and leaks every time you start the generator set and every eight hours when you run it continuously.

## 1.8 Earth Ground Connection

The neutral of the generator set may be required to be bonded to earth ground at the generator set location, or at a remote location, depending on system design requirements. Consult the engineering drawings for the facility or a qualified electrical design engineer for proper installation.

### NOTICE

**The end user is responsible to make sure that the ground connection point surface area is clean and free of rust before making a connection.**

### NOTICE

**The end user is responsible for making sure that an earthing arrangement that is compliant with local conditions is established and tested before the equipment is used.**

## 2 Introduction

---

**⚠ WARNING**

***Hazardous Voltage***

***Contact with high voltages can cause severe electrical shock, burns, or death.***

***Make sure that only a trained and experienced electrician makes generator set electrical output connections, in accordance with the installation instructions and all applicable codes.***

**⚠ WARNING**

***Electrical Generating Equipment***

***Faulty electrical generating equipment can cause severe personal injury or death.***

***Generator sets must be installed, certified, and operated by trained and experienced person in accordance with the installation instructions and all applicable codes.***

### 2.1 About This Manual

This manual provides troubleshooting and repair information for the generator sets listed on the front cover.

The information contained within the manual is based on information available at the time of going to print. In line with the Cummins Inc. policy of continuous development and improvement, information may change at any time without notice. The users should therefore make sure that before commencing any work, they have the latest information available. The latest version of this manual is available on QuickServe Online (<https://quickserve.cummins.com>).

This manual does not include instructions for servicing printed circuit board assemblies. After determining that a printed circuit board assembly is faulty, replace it. Do not repair it. Attempts to repair a printed circuit board can lead to costly damage to the equipment.

This manual contains basic (generic) wiring diagrams and schematics that are included to help in troubleshooting. The wiring diagrams and schematics that are maintained with the unit should be updated when modifications are made to the unit.

Operating and basic maintenance instructions are in the applicable generator set operator manual. Read and carefully observe all instructions and precautions in this manual.

## 2.2 Test Equipment

To perform the test procedures in this manual, the following test equipment must be available:

- True RMS (Root Mean Square) meter for accurate measurement of small AC and DC voltages
- Grounding wrist strap to prevent circuit board damage due to electrostatic discharge (ESD)
- Wheatstone bridge or digital ohmmeter
- Load bank
- Megger or insulation resistance meter

## 2.3 Schedule of Abbreviations

This list is not exhaustive. For example, it does not identify units of measure or acronyms that appear only in parameters, event/fault names, or part/accessory names.

Abbr.	Description	Abbr.	Description
AC	Alternating Current	LED	Light-Emitting Diode
AMP	AMP, Inc. (part of Tyco Electronics)	MFM	Multifunction Monitor
ANSI	American National Standards Institute	Mil Std	Military Standard
ASOV	Automatic Shut Off Valve	MPU	Magnetic Pickup
ASTM	American Society for Testing and Materials (ASTM International)	NC	Normally Closed
ATS	Automatic Transfer Switch	NC	Not Connected
AVR	Automatic Voltage Regulator	NFPA	National Fire Protection Agency
AWG	American Wire Gauge	NO	Normally Open
CAN	Controlled Area Network	NWF	Network Failure
CB	Circuit Breaker	OEM	Original Equipment Manufacturer
CE	Conformité Européenne	OOR	Out Of Range
CCA	Cold Cranking Ampere	OORH/ ORH	Out Of Range High



<b>Abbr.</b>	<b>Description</b>	<b>Abbr.</b>	<b>Description</b>
CFM	Cubic Feet per Minute	OORL/ORL	Out Of Range Low
CGT	Cummins Generator Technologies	PB	Push Button
CMM	Cubic Meters per Minute	PCC	PowerCommand® Control
CT	Current Transformer	PGI	Power Generation Interface
DC	Direct Current	PGN	Parameter Group Number
DEF	Diesel Exhaust Fluid	PI	Proportional/Integral
DPF	Diesel Particulate Filter	PID	Proportional/Integral/Derivative
EBS	Excitation Boost System	PLC	Programmable Logic Controller
ECM	Engine Control Module	PMG	Permanent Magnet Generator
ECS	Engine Control System	PPE	Personal Protective Equipment
EMI	Electromagnetic Interference	PT	Potential Transformer
EN	European Standard	PTC	Power Transfer Control
EPS	Engine Protection System	PWM	Pulse-Width Modulation
E-Stop	Emergency Stop	RFI	Radio Frequency Interference
FAE	Full Authority Electronic	RH	Relative Humidity
FMI	Failure Mode Identifier	RMS	Remote Monitoring System
FSO	Fuel Shutoff	RMS	Root Mean Square
Genset	Generator Set	RTU	Remote Terminal Unit
GCP	Generator Control Panel	SAE	Society of Automotive Engineers
GND	Ground	scfh	Standard Cubic Feet of gas per Hour
HMI	Human-Machine Interface	SCR	Selective Catalytic Reduction

Abbr.	Description	Abbr.	Description
IC	Integrated Circuit	SPN	Suspect Parameter Number
ISO	International Organization for Standardization	SW_B+	Switched B+
LBNG	Lean-Burn Natural Gas	UL	Underwriters Laboratories
LCD	Liquid Crystal Display	UPS	Uninterruptible Power Supply
LCT	Low Coolant Temperature		

## 2.4 Related Literature

Before any attempt is made to operate the generator set, the operator should take time to read all of the manuals supplied with the generator set and familiarize themselves with the warnings and operating procedures.

<b>NOTICE</b>
<p><b>A generator set must be operated and maintained properly if you are to expect safe and reliable operation. The Operator manual includes a maintenance schedule and a troubleshooting guide.</b></p> <p><b>The Health and Safety manual must be read in conjunction with this manual for the safe operation of the generator set, as well as the Warranty Statements.</b></p>

The literature provided with the generator set is as follows:

- Installation Manual (A053X172)
- Operator Manual (A053X174)
- Quick Start Installation Guide (A053X181)
- Quick Start Operator Guide (A053X183)
- Health and Safety Manual (0908-0110-00)
- Global Warranty Statement (A056F206)
- Emission Warranty Statement (Federal Emissions EPA Title 40 CFR Part 90 Component Warranty) (A028X278)

The relevant manuals appropriate to your generator set are also available. The documents below are in English:

- Generator Set Service Manual (A053X177)
- RA Series RA112L1 Automatic Transfer Switch Owner Manual (A052S254) - if applicable

- RA Series 100A/200A/400A Automatic Transfer Switch Owner Manual (A046S594) - if applicable
- Parts Manual (A053X179)
- Standard Repair Times - HO Family (A053X186)
- Service Tool Manual (A043D529)
- Warranty Failure Code Manual (F1115C)
- Engineering Application Manual T-030: Liquid Cooled Generator Sets (A040S369)

## 2.5 Model Specifications

**TABLE 1. MODEL VARIATIONS**

Model	Natural Gas or Propane Vapor	kW	Amps	Frequency	Voltage
C13N6H	Both	13	54.2	60 Hz	120/240 VAC Single Phase
C17N6H	Both	17	70.8		
C20N6H, C20N6HC	Natural Gas Only	18	75		
	Propane Vapor Only	20	83.3		

**NOTICE**

**Maximum load imbalance allowed is 50% of generator set rating.**

**TABLE 2. COLD WEATHER SPECIFICATIONS (ALL MODELS)**

Temperature	Description
Above 4 °C (40 °F)	No starting aids required
-17 to 4 °C (0 to 40 °F)	Alternator and regulator heaters (supplied with the generator set)
Below -17 °C (0 °F)	<ul style="list-style-type: none"> <li>• Alternator and regulator heaters</li> <li>• 0W30 oil (see the oil recommendation below)</li> <li>• Extreme cold weather kit (A045B984) (includes battery and oil heaters)</li> </ul>

**TABLE 3. FUEL SPECIFICATIONS (AT FULL LOAD) (ALL MODELS)**

Type	C13N6H		C17N6H		C20N6H, C20N6HC	
	scfh	BTU/hr	scfh	BTU/hr	scfh	BTU/hr
Natural Gas	253	260,000	289	297,000	300	309,000
Propane	85	212,000	101	252,000	116	290,000
Fuel Pressure	Natural Gas: 3.5 - 12 inch water column (0.9 - 3.0 kPa) Propane Vapor: 1.5 - 3.0 kPa (6 - 12 inch water column) Maximum pressure for either fuel under any condition: 3.2 kPa (13 inch water column)					

**TABLE 4. ENGINE SPECIFICATIONS (ALL MODELS)**

Type	Value
Engine	2 cylinder v-twin, OHV, air-cooled, 4-stroke, spark ignited
Displacement	999 cc (60.9 in <sup>3</sup> )
Spark Plug Gap	0.7 - 0.8 mm (0.027 - 0.031 in)
Spark Plug Torque (Cold Engine)	25 - 30 Nm (18 - 22 ft-lb)
RPM	3600
Lubricating Oil Pressure at Rated Speed (Minimum)	310 kPa (45 psi)
Oil Recommendation	Full synthetic gasoline engine oil which meets or exceeds API service SN/SN-RC and ILSAC GF-5: <ul style="list-style-type: none"> <li>• 5W30: Temperatures above -17 °C (0 °F)</li> <li>• 0W30: All temperatures, required below -17 °C (0 °F)</li> </ul>
<b>Lubricating Oil Capacity:</b>	
Lubricating Oil Pressure at Rated Speed (Minimum)	310 kPa (45 psi)
--Full at High Mark on Dipstick	2.3 L (2.4 qt)
--Low Mark on Dipstick	1.3 L (1.4 qt)

**TABLE 5. GENERATOR SET SIZE (ALL MODELS)**

Dimension	Value
Length	865 mm (34.1 in)
Width	915 mm (36 in)
Height	694 mm (27.3 in)

**TABLE 6. GENERATOR SET WET WEIGHT (INCLUDING BATTERY)**

Model	Value
C13N6H	218 kg (479 lb)
C17N6H, C20N6H, C20N6HC	241 kg (531 lb)

**TABLE 7. GENERATOR SET DERATING GUIDELINES**

Model	Engine Power Available Up To...		Derate At...	
	Elevation	Ambient Temperature	Elevation	Temperature
C13N6H	2100 m (6900 ft)	25 °C (77 °F)	3.5% per 300 m (1000 ft)	1% per 5.5 °C (10 °F)
C17N6H	300 m (1000 ft)	25 °C (77 °F)		
C20N6H, C20N6HC	0 m (0 ft)	15 °C (60 °F)		

**NOTICE**

***Derating guidelines:*** This product's output power is limited by factors such as BTU content of fuel, ambient temperature, altitude, humidity, engine condition, etc. The derating guidelines are based on properly maintained product, using the appropriate fuel. Derate values are based on expected engine power changes from elevation and temperatures listed.

**TABLE 8. ALTERNATOR SPECIFICATIONS (ALL MODELS)**

Type	Specification
Design	Rotating field
Poles	2
RPM	3600
Voltage	240
Hz	60

**TABLE 9. CONTROL SPECIFICATIONS (ALL MODELS)**

Control
Integrated Microprocessor-Based Engine, Alternator, Transfer Switch Controller


**TABLE 10. DC SYSTEM SPECIFICATIONS (ALL MODELS)**

Type	Value
Nominal Battery Voltage	12 VDC
Battery Group	51 R
Battery Type	Lead Acid
Minimum Cold Crank Amps (CCA)	450

## 2.6 After Sales Services

Cummins offers a full range of maintenance and warranty services.

### Maintenance

 WARNING
<p><b><i>Electrical Generating Equipment</i></b>  <b><i>Incorrect service or parts replacement can result in severe personal injury, death, and/or equipment damage.</i></b>  <b><i>Make sure service personnel are qualified to perform electrical and mechanical service.</i></b></p>

For expert generator set service at regular intervals, contact your Cummins Inc. service provider. See [power.cummins.com/sales-service-locator](http://power.cummins.com/sales-service-locator) for service locations that service this application. Maintenance tasks should only be undertaken by trained and experienced technicians provided by your Cummins Inc. service provider.

### Warranty

For details of the warranty coverage for your generator set, refer to the *Global Warranty Statement* listed in the Related Literature section.

In the event of a breakdown, prompt assistance can normally be given by factory trained service technicians with facilities to undertake all minor and many major repairs to equipment on site.

Extended warranty coverage is also available.

For further warranty details, contact your authorized service provider.

**NOTICE**

**Damage caused by failure to follow the manufacturer's recommendations will not be covered by the warranty. Please contact your authorized service provider.**

## Warranty Limitations

For details of the warranty limitations for your generator set, refer to the warranty statement applicable to the generator set.

## How to Obtain Service

When a product requires service, contact the nearest authorized Cummins Inc. service provider. To locate the service provider, refer to [power.cummins.com](http://power.cummins.com) and select Sales & Service Locator. When contacting the service provider, always supply the complete model, specification, and serial number as shown on the nameplate.

## Service Technician Support

For technical support for service technicians, call 1-855-TECH711 (1-855-832-4711) to reach the Channel One Technical Support Hotline in the United States or Canada. Distributors should contact their Cummins Inc. service contact.

## Fuel Information Needed for Service Issue

When servicing is needed on a failed fuel tank, the following questions must be answered and conveyed via the submission of the Technical Support Request form (TSR).

1. Is there an actual confirmed leak?
  - Has the rupture basin alarm gone off?
  - What Fault Code(s) are present?
  - Is the sensor functioning properly?
  - Is there visible fuel in the basin or outside the tank (i.e. is there an EPA concern)?
  - If so, what is the leak rate?
  - Is the fluid fuel and NOT water?
  - What is the level of the fuel, in inches, in the tank and basin? A dipstick may be required to obtain an accurate reading.
  - Can the leak locale be identified?

**⚠ CAUTION****High Pressure**

**Excessive pressurization can rupture tanks or basins which can result in severe personal injury or death.**

**Remove all liquids before pressure testing. Do not exceed 2 psig when testing a tank or basin.**

- Has the tank been previously repaired?
  - Is there evidence of physical damage that may be contributing to the leak?
  - Pictures may convey a great deal of information and should be considered.
2. What are the CPG and manufacturer's details associated with the tank? Include the following in the Issue:
- CPG part number.
  - Manufacturer's part number, model, serial number and date of manufacture.
3. What time frame is required for the needed repair or replacement (i.e. how sensitive of an issue is this with the client and do they have any flexibility in the repair timing)?
- If replacement, has there been an order placed for a new tank?
  - If ordered, is it categorized as machine down?
  - If not, then please update the order accordingly.
  - If an order has been placed, the Issue is to reflect this data (order number) as well.

### Obtaining Information Needed for Fuel Tank Service Issues

**⚠ CAUTION****High Pressure**

**Excessive pressurization can rupture tanks or basins which can result in severe personal injury or death.**

**Remove all liquids before pressure testing. Do not exceed 2 psig when testing a tank or basin.**

To aid in identifying/isolating the leak or obtaining some of the information needed for Fuel Tank Service Issues:

1. Seal all penetrations/fittings with plugs except for one.
2. For the remaining penetration, fit up a regulated pressure source with a calibrated pressure gauge and a pressure relief valve (set to no more than 2.5 psig).



3. Pressurize the tank or basin to 2 psig and observe for the following:

- For secondary tank (basin) work, spray all exterior weld seams with a soap water solution. Observe the pressure gauge for no change in a 30 minute period and visually observe the exterior seams for bubbling. Results are to be conveyed in the Issue details.
- For the primary fuel tank, spray all exterior weld seams with a soap water solution. Observe the pressure gauge for no change in a 30 minute period and visually inspect the interior of the basin to the maximum extent possible. Results are to be conveyed in the Issue details.

**NOTICE**

**For further questions or concerns regarding the information stated above, please contact (in the following order):**

1. Your local Service Manager
2. DFSE-Counterpart
3. The Cummins Distributor Technical Support Line (1-812-377-6517)

## Manufacturing Facilities

Facility	Address	Phone Numbers
U.S. and CANADA	Cummins Inc. 1400 73rd Ave. NE Minneapolis, MN 55432 USA	Toll Free 1-800-CUMMINS (1-800-286-6467) Phone +1 763-574-5000 Fax +1 763-574-5298
EMEA, CIS	Cummins Inc. Columbus Avenue Manston Park Manston, Ramsgate Kent CT12 5BF United Kingdom	Phone +44 1843 255000 Fax +44 1843 255902
	Cummins Inc. Royal Oak Way South Daventry Northamptonshire NN11 8NU United Kingdom	Phone +44 1843 255000 Fax +44 1843 255902
ASIA PACIFIC	Cummins Inc. 10 Toh Guan Road #07-01 TT International TradePark Singapore 608838	Phone +65 6417 2388 Fax +65 6417 2399
BRAZIL	Rua Jati, 310, Cumbica Guarulhos, SP 07180-900 Brazil	Phone +55 11 2186 4195 Fax +55 11 2186 4729
CHINA	Cummins Inc. 2 Rongchang East Street, Beijing Economic – Technological Development Area Beijing 100176, P.R. China	Phone 86 10 59023001 Fax +86 10 5902 3199
INDIA	Cummins Inc. Power Generation Business Unit, Plot No B-2, SEZ Industrial Area, Village-Nandal & Surwadi, Taluka- Phaltan Dist- Satara, Maharashtra 415523 India	Phone +91 021 66305514
LATIN AMERICA	3350 Southwest 148th Ave. Suite 205 Miramar, FL 33027 USA	Phone +1 954 431 551 Fax +1 954 433 5797

---

<b>Facility</b>	<b>Address</b>	<b>Phone Numbers</b>
MEXICO	Eje 122 No. 200 Zona Industrial San Luis Potosi, S.L.P. 78395 Mexico	Phone +52 444 870 6700 Fax +52 444 824 0082

This page is intentionally blank.

## 3 Startup

---

### 3.1 "Establishing Communications" Message

#### NOTICE

Once the battery is connected to the generator set and any display button is pressed, the local display shows an "establishing communications" message for approximately 5 seconds. (This may take longer if the signal integrity is poor between the control and display due to a bad wire or Electro-Magnetic Interference [EMI].) Once communication is established, the display shows the HOME screen.

The "establishing communications" message will also be displayed whenever the control is brought out of "sleep" mode by pressing any button on the display. Sleep mode is entered after 30 minutes without utility or generator set power to preserve battery energy since the battery charger will not have AC power. The 30-minute timer is reset with any button press on the display.

### 3.2 "Clock Setup" Screen

#### NOTICE

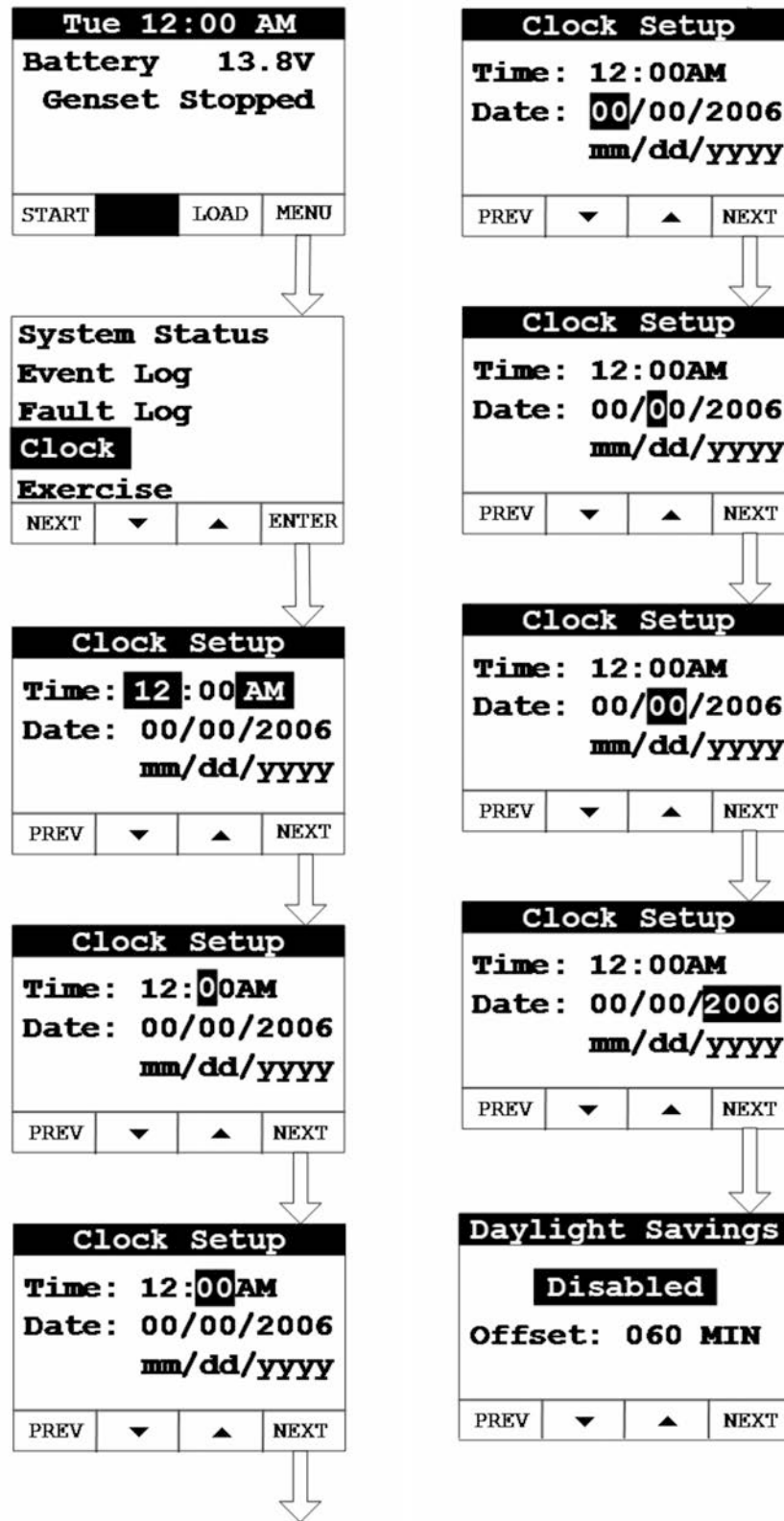
The Clock needs to be reset whenever the battery power is lost or disconnected, or the control has entered "sleep" mode. Sleep mode is entered after 30 minutes without utility or generator set power to preserve battery energy since the battery charger will not have AC power. The 30-minute timer is reset with any button press on the display.

#### NOTICE

The optional Remote Monitoring System (RMS) uses the generator set's clock. The clock must be set accurately for the RMS to function properly.

To set up the generator set clock for the current date and time:

1. From the Main screen, select **Menu**.
2. Use the arrow keys to highlight **Clock**. Select the **Enter** key.
3. Use the arrow keys to set the time and date.



**FIGURE 2. CLOCK SETUP SCREEN**

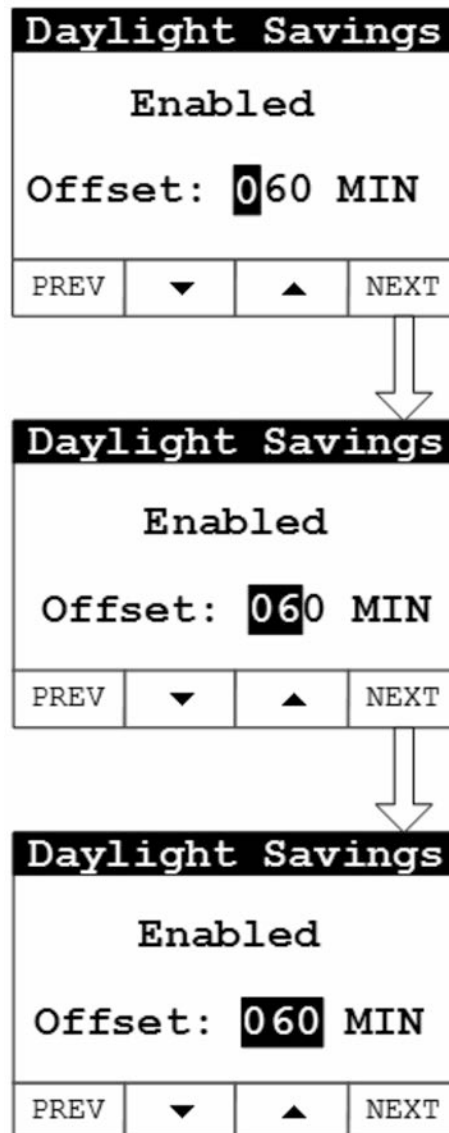
4. Select the **Next** key to go to the Daylight Savings screen.

5. Use the arrow keys to enable/disable Daylight Savings. If enabling, select the **Next** key to highlight the **Offset** field.



**FIGURE 3. DAYLIGHT SAVINGS TIME (ENABLED)**

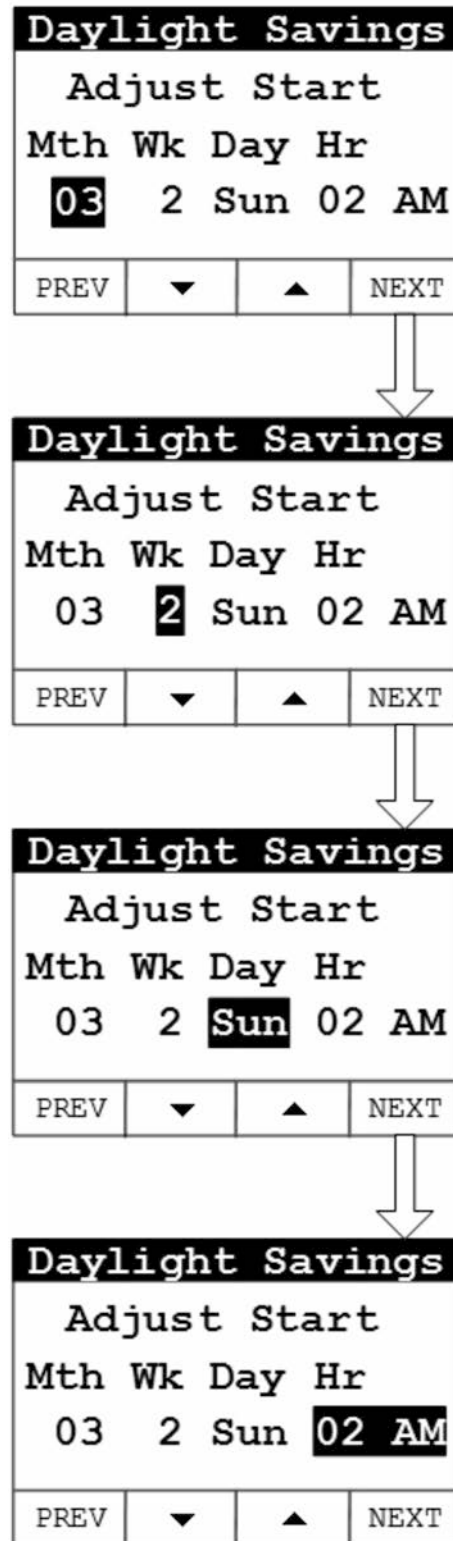
6. Use the arrow keys and **Next** key to set the offset value for Daylight Savings time.



**FIGURE 4. OFFSET VALUE**

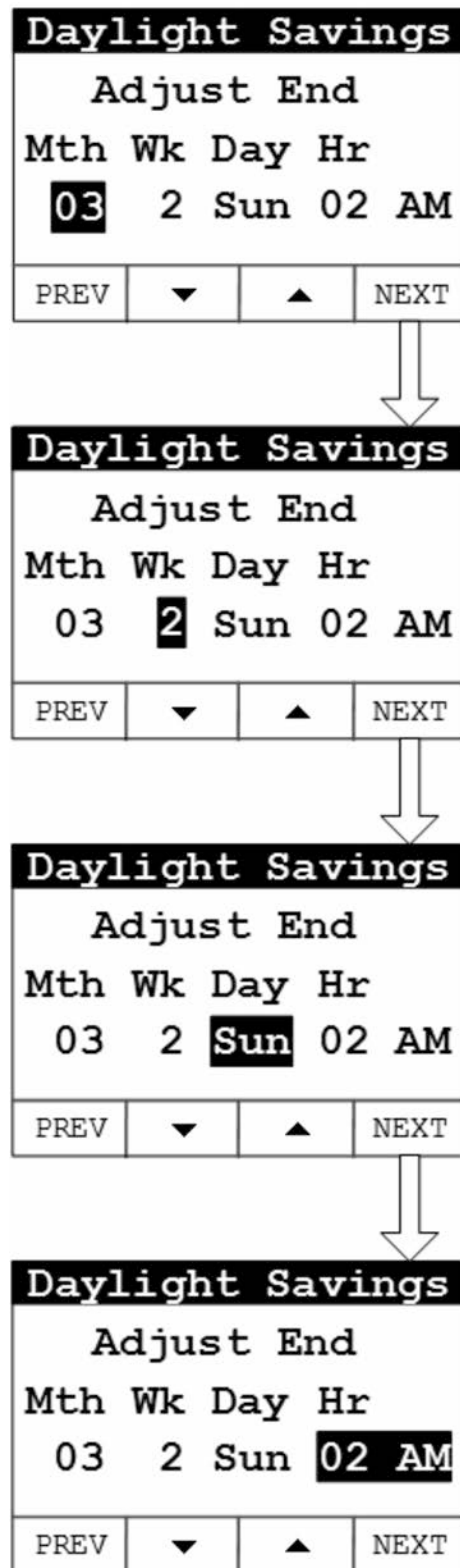
7. Select the **Next** key to go the screen that is used to set up when Daylight Savings should start. Use the arrow keys and **Next** key to set Month (1 – 12), Week (0 – 5), Day (Sun – Sat) and Hour (12AM – 12PM).





**FIGURE 5. DAYLIGHT SAVINGS TIME (START TIME SETUP)**

8. Select the **Next** key to go the screen that is used to set up when Daylight Savings should end. Use the arrow keys and **Next** key to set Month (1 – 12), Week (0 – 5), Day (Sun – Sat) and Hour (12AM – 12PM).



**FIGURE 6. DAYLIGHT SAVINGS TIME (END TIME SETUP)**

9. Keep selecting the **Back** button to save the settings and return to the main screen.

### 3.3 "Exercise" Screen

When installing an RA series transfer switch, follow these steps to configure the Exercise mode in the generator set's local display or remote display.

#### NOTICE

**Exercise settings need to be reset whenever battery power is lost or disconnected, or the control has entered "sleep" mode.**

#### NOTICE

**Sleep mode is entered after 30 minutes without utility or generator set power to preserve battery energy since the battery charger will not have AC power. The 30-minute timer is reset with any button press on the display.**

To set up the exercise function:

1. From the Main screen, select **Menu**.
2. Use the arrow keys to highlight **Exercise**. Select the **Enter** key.

#### NOTICE

**If the time and date have not been set, a pop-up will appear that says, "Set Valid Date and Time".**

3. Use the arrow keys to enable or disable the **Crank Exercise** feature. Select the **Next** key to go to the **Exercise Time** field. See the Exercise Sequences section in the operator manual for more information.

#### NOTICE

**When the Crank Exercise feature is enabled, an exercise command will cause the engine starter to engage and rotate the engine, but will not allow the engine to start. This feature allows the control system to monitor critical generator set systems without running the engine. When Crank Exercise is enabled, the generator set's exercising will alternate between the Crank Exercise sequence and the normal exercise sequence (that is, engine running) at scheduled times.**

4. Use the arrow keys to set how long the generator set will exercise (from 1 to 20 minutes). Select the **Next** key to go to the **Exercise** field. The Exercise Sched screen appears.
5. Use the arrow keys to set how often the generator set will exercise. The frequency selections are:
  - Weekly
  - Bimonthly
  - Monthly

- Never

Select the **Next** key to go to the date and time fields.

6. Use the arrow keys to set the day and time the generator set will be exercised. Select the **Next** key to highlight the **Exercise Now** field.
7. Select either arrow key to start the Exercise Now function.

**NOTICE**

**Initiating the Exercise Now function will cause the generator set to start immediately and run for the amount of time indicated by the Exercise Time field, or run the Crank Exercise sequence. The ATS does not transfer to generator power during exercise mode. Normally scheduled exercise events will occur after the completion of the immediate exercise event.**

8. Keep selecting the **Back** button to save the settings and return to the Main screen.

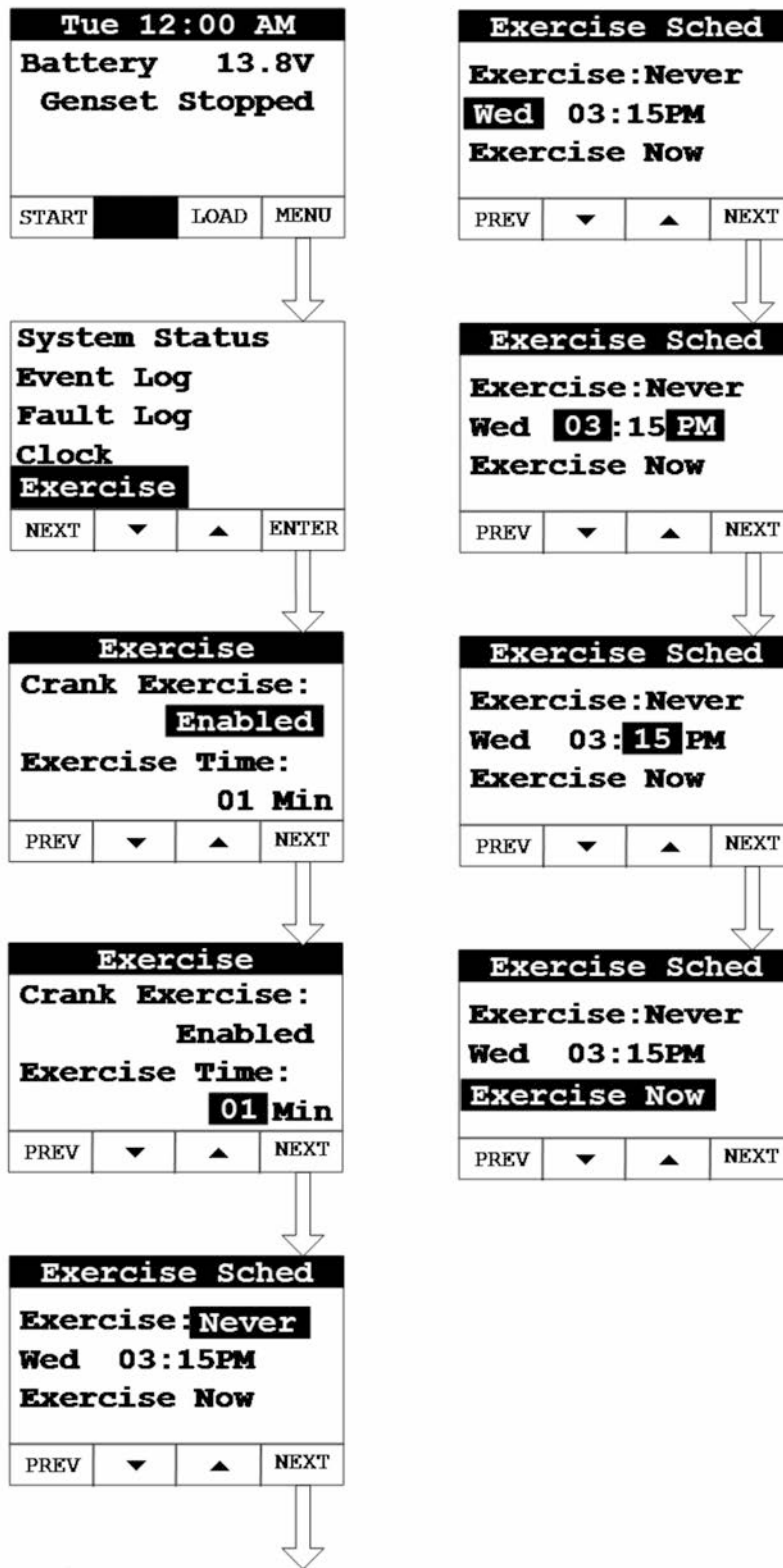


FIGURE 7. EXERCISE SETUP SCREEN

---

## 3.4 "Brightness and Contrast" Screen

To adjust the brightness and contrast of the display:

1. From the Main screen, select **Menu**.
2. Use the arrow keys to highlight **Display Setup**. Select the **Enter** key.
3. Use the arrow keys to set brightness and contrast for the display.
4. Keep selecting the **Back** button to save the settings and return to the Main screen.

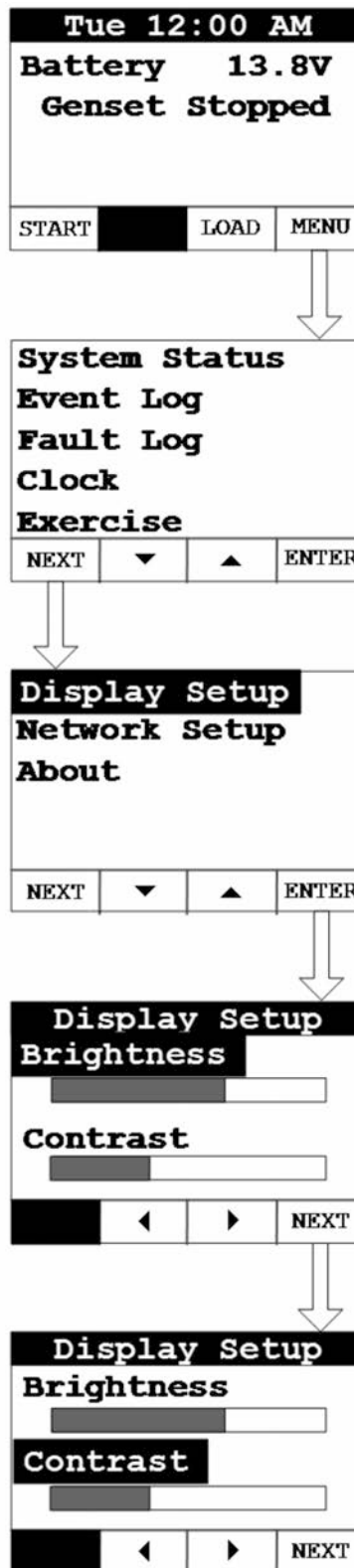


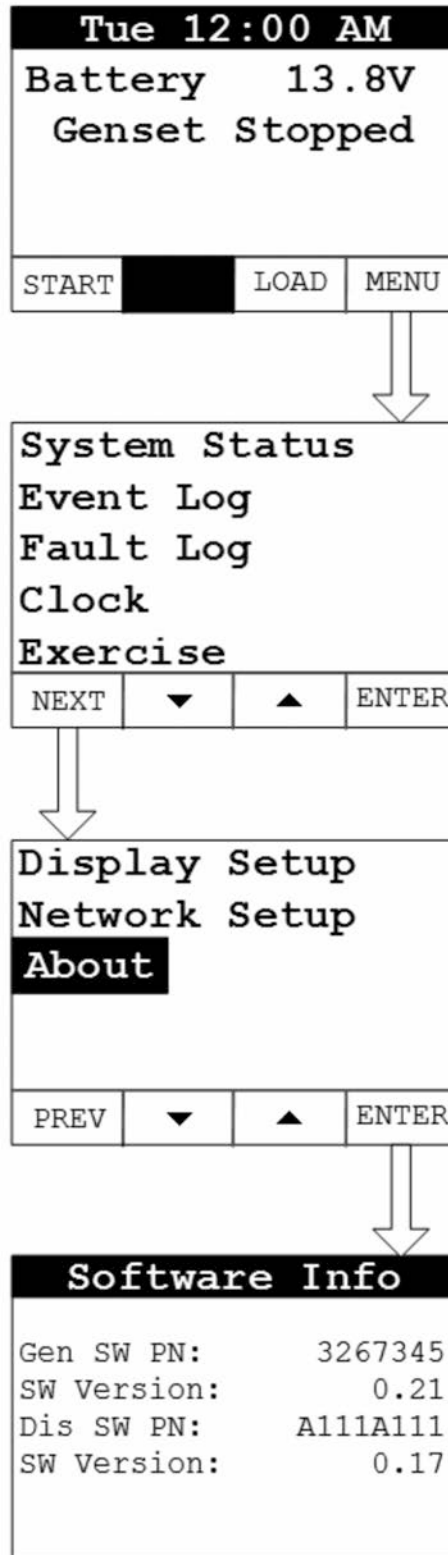
FIGURE 8. BRIGHTNESS AND CONTRAST SCREEN

## 3.5 "About" Screen

To retrieve information about the display:

1. From the Main screen, select **Menu**.
2. Use the arrow keys to highlight **About**. Select the **Enter** key.





**FIGURE 9. ABOUT SCREEN**

## 3.6 "Event Log" Screen

To retrieve information from the Event Log:

1. From the Main screen, select **Menu**.
2. Use the arrow keys to highlight **Event Log**. Select the **Enter** key.
3. Use the arrow keys to navigate through the Event Log.
4. Keep pressing the **Back** button to return to the Main screen.

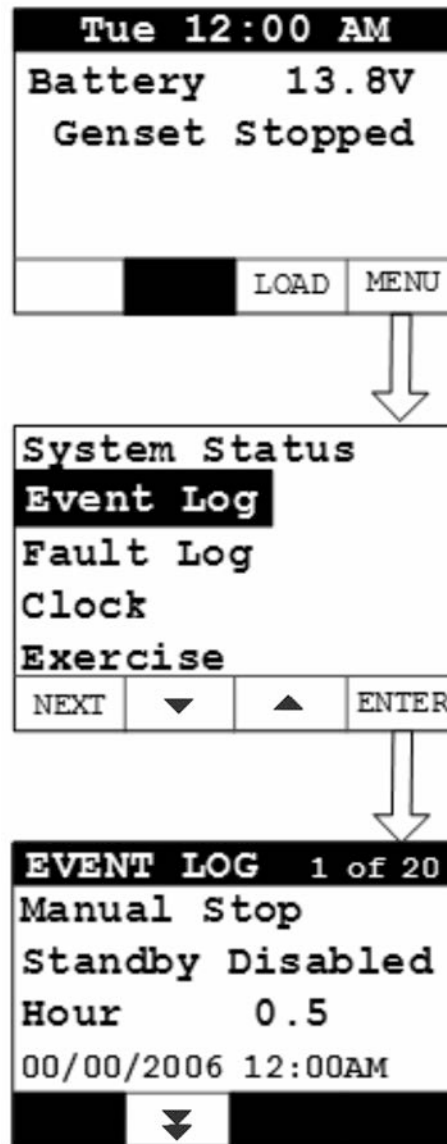


FIGURE 10. EVENT LOG SCREEN

---

## 3.7 "Fault Log" Screen

To retrieve information from the Fault Log:

1. From the Main screen, select **Menu**.
2. Use the arrow keys to highlight **Fault Log**. Select the **Enter** key.
3. Scroll through the fault log using the up and down double-arrows. Each screen provides a brief description of the fault, the fault code number, the engine hours and the time and date of the fault.

**NOTICE**

**If there are no faults recorded, the "No Stored Faults" screen will appear.**

4. Keep pressing the **Back** button to return to the Main screen.



FIGURE 11. FAULT LOG SCREEN

### 3.8 "System Status" Screen

To retrieve system status:

1. From the Main screen, select **Menu**.
2. Use the arrow keys to highlight **System Status**. Select the **Enter** key.
3. Keep pressing the **Back** button to return to the Main screen.



FIGURE 12. SYSTEM STATUS SCREEN

### 3.9 "Mode" Screen

#### **⚠ WARNING**

*To prevent unexpected starts from remote devices, disable Remote mode and disconnect the connector on the back of the local display wired to any remote mounted displays.*

When Remote is set to Enabled via the local display, the "Remote On" LED on the front of the display will illuminate indicating that the control will accept start commands from remote displays or remote monitoring systems including a web page or cell phone app.

**NOTICE**

**The Remote function can only be activated (that is, enabled) from the local display.**

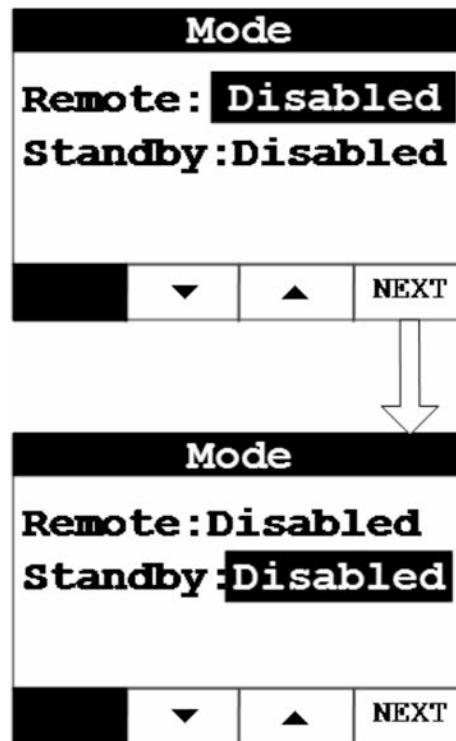
When Standby is on or set to Enabled, the “Standby On” LED on the front of the display will illuminate indicating the control will start the generator set in response to a utility power outage. Standby can be turned on at the local display. It can also be enabled with a remote display, web page, or a cell phone app if Remote has already been enabled at the local display. The Standby function **cannot** be enabled remotely unless the Remote function is on. A manual Start or Stop event will disable the Standby function. (If the manual Stop event is performed at the local display, the Remote mode will also be disabled.)

1. To enable or disable the Remote and Standby modes on the **LOCAL** display:
  - a. From any screen, select the **Mode** key to get to the Mode screen.
  - b. Use the arrow keys to enable or disable the Remote mode. Select the **Next** key to go to the next screen.
  - c. Use the arrow keys to enable or disable the Standby mode.

**NOTICE**

**Whenever Standby is enabled, the Remote mode will also automatically be enabled.**

- d. Keep pressing the **Back** button to save the settings and return to the Main screen.



**FIGURE 13. MODE SETUP SCREEN (LOCAL DISPLAY)**

2. To enable or disable the Standby mode on the **REMOTE** display:

**NOTICE**

Remote must be enabled before Standby mode can be changed from the Remote display. If Remote mode is not enabled, Standby will remain disabled and cannot be changed.

- a. From any screen, select the **Mode** key to get to the Mode screen.
- b. Use the arrow keys to enable or disable the Standby mode.
- c. Keep pressing the **Back** button to save the settings and return to the Main screen.



**FIGURE 14. MODE SETUP SCREEN (REMOTE DISPLAY)**

## 3.10 Automatic Load Management

### NOTICE

**The capability to automatically add or remove specific electrical loads from the generator set requires that load management devices be wired to the generator set load management outputs.**

When the generator set is started automatically in Standby mode due to a loss of utility or manually by the operator, the control will energize all four load management outputs, disconnecting the associated loads from AC power. Once the transfer switch transfers to generator set power, the generator set control will evaluate the total load on the generator set versus a set point programmed into the control (80% of rated).

If the generator set's total load is below the set point, the generator set control will sequentially add the highest priority managed load every three minutes. Managed loads will continue to be added as long as the size of the next priority load to be added won't increase total generator set load above the set point. The control measures and stores the size of each managed load in its memory. Load priorities are in the following order:

- Priority #1: load control 1
- Priority #2: load control 2
- Priority #3: load control 3
- Priority #4: load control 4

If the load on the generator set is reduced at any time to below the set point, the control will add the next highest priority managed load in three minutes provided it does not increase the total generator set load above the set point.

If the load on the generator set exceeds 95% of its rating, the generator set control will begin disconnecting the lowest managed priority loads in sequence every second until the load on the generator set is below 95% of its rating.

Priority #1 load is always the first added and the last disconnected; therefore, it should be wired to the managed load deemed most critical to the homeowner. Priority #2 load cannot be added before priority #1 load, nor can it be disconnected before priority #3 or #4, etc.

## 3.11 Startup

1. Verify that the installation was completed correctly.
2. Read the operator manual. Perform the pre-start checks as instructed.
3. Connect the battery cables to the battery with the positive (+) cable first. Immediately cover the battery post and terminal with the red cover provided on the battery cable.



- 
4. Although the generator set is shipped from the factory with the proper level of engine oil, check the oil level before it is started.
  5. Start and test the system.
  6. Operate the generator set following all the instructions and precautions in the operator manual.

**NOTICE**

**Before leaving the site, if the generator set is ready to be placed in service, enable the Remote and Standby modes from the local display.**

**NOTICE**

**Contact your local Cummins service provider if you encounter a fault code.**

This page is intentionally blank.

# 4 Operation

---

## 4.1 Introduction

This section describes the operation of the generator set. The text should be read in conjunction with the Control System section of this manual.

All indicators, control switches/buttons, and graphical display are located on the face of the local and remote displays.

**⚠ CAUTION**

***To avoid injury, be sure to read the instructions in the Operating the Generator Set Cover Safely section before lifting the generator set cover.***

## 4.2 General Operating Conditions

The area surrounding the generator set is critical for safety and its performance. Follow the guidelines below.

- Do not stack anything on top of the generator set.
- Do not store anything inside of the generator set.
- Keep areas clear in front of the cool air in and hot air out (free of obstructions, debris, plants, etc.).

**NOTICE**

**All maintenance procedures must be performed or supervised by authorized and trained service personnel only.**

## 4.3 Generator Set Operation

**⚠ WARNING**

***Combustible Vapors***

***Do not operate a generator set where there are or can be combustible vapors.***

***These vapors can be sucked through the air intake system and cause engine acceleration and overspeeding, which can result in a fire, an explosion, personal injury and extensive property damage.***

Correct care of your generator set will result in longer life, better performance, and more economical operation.

Cummins Inc. does not know how you will use your generator set. The equipment owner and operator, therefore, is responsible for safe operation in the installation site environment. Consult your authorized Cummins Inc. service provider for further information.

## Sequence of Operation

### NOTICE

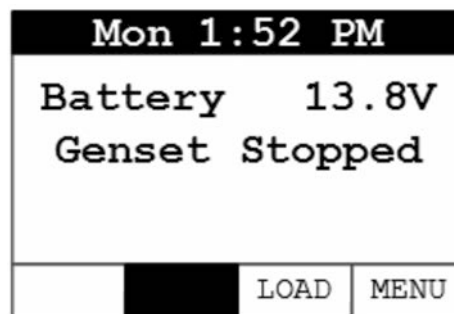
The following sequences are based on an approximate time duration. Your generator set may vary slightly from the timing diagrams in this manual. All referenced times are based on default control settings. The following sequences are applicable to generator sets connected to a single phase RA series transfer switch.

### Auto Start Sequence (with an RA Series Transfer Switch)

#### NOTICE

Standby Mode must be enabled for Auto Start to execute.

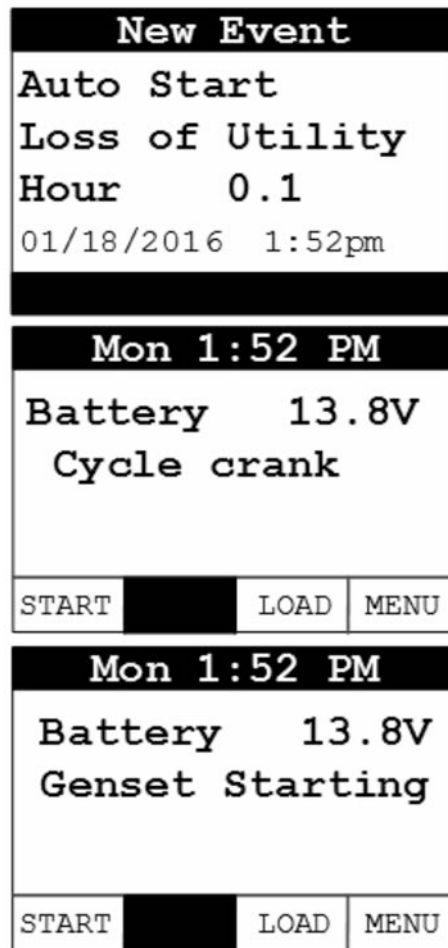
In normal operation, utility power is provided through the transfer switch to the building loads; the generator set is not running.



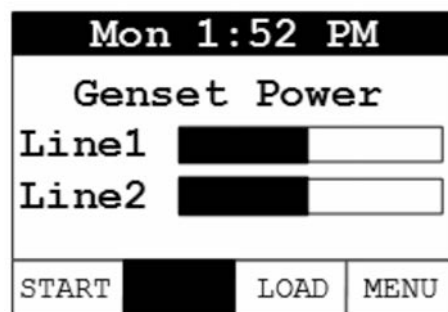
**FIGURE 15. GENSET STOPPED**

If utility power is not available (that is, there is a power outage), the following sequence will be executed to connect building load to the generator set, and then reconnect building load back to the utility power when it is available.

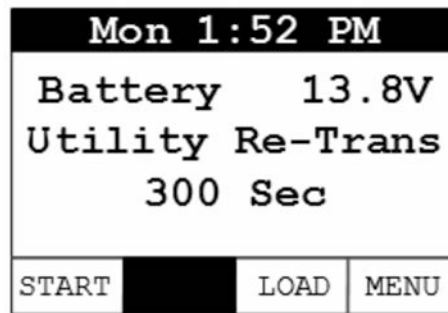
1. The generator set starts.

**FIGURE 16. GENSET STARTING**

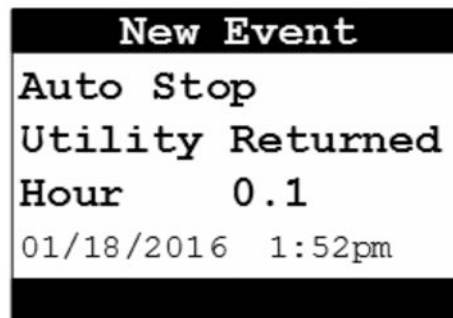
2. After the generator set reaches rated voltage and frequency, the transfer switch transfers the building load to the generator set. The building's electrical power is now provided by the generator set.

**FIGURE 17. GENSET POWER**

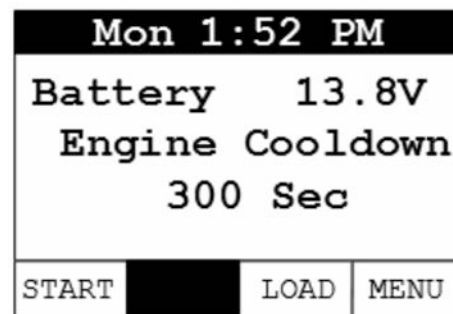
3. When utility power is restored, the sequence to transfer building load to the utility begins.
4. The generator set continues to run and waits for utility power to stabilize.

**FIGURE 18. UTILITY RE-TRANS**

5. When utility power is stable for 5 minutes, the transfer switch connects the building load back to utility power.

**FIGURE 19. UTILITY RETURNED**

6. The generator set runs an additional 5 minutes to cool down and then shuts off.

**FIGURE 20. ENGINE COOLDOWN**

7. Normal operation resumes. See [Figure 15](#).

### Exercise Sequences

1. **Standard Exercise sequence:**

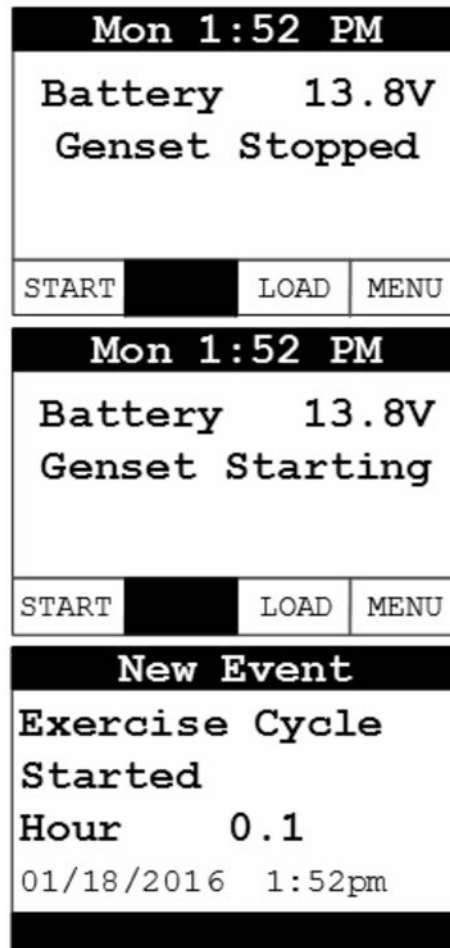
<b>NOTICE</b>
<b>Standby Mode must be enabled for standard exercise to execute.</b>

**NOTICE**

**While the generator set is exercising, the building load remains connected to the utility; it is not transferred to the generator set.**

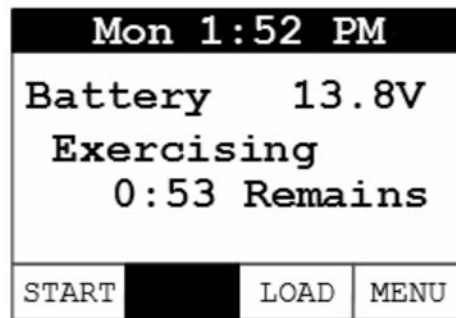
The following steps will be executed when the programmed exercise day and time are reached or the Exercise Now option is selected and the standard exercise sequence is run:

- a. The generator set starts.

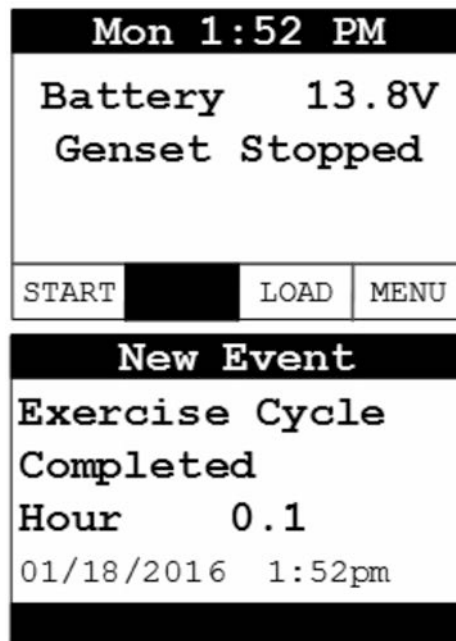


**FIGURE 21. EXERCISE CYCLE STARTED**

- b. After the generator set reaches rated speed and voltage, the exercise timer is started.

**FIGURE 22. EXERCISING**

- c. When the defined exercise time has completed, the generator set stops and normal operation resumes.

**FIGURE 23. EXERCISE CYCLE COMPLETED**

## 2. Crank Only Exercise Sequence

### NOTICE

**Standby Mode must be enabled for Crank Exercise to execute.**

When Crank Exercise is enabled, the generator set will alternate between crank only exercise and standard (that is, generator set running) exercise sequences.

The following steps will be executed when the programmed exercise day and time are reached or the Exercise Now option is selected and the crank only exercise sequence is run:

- a. The generator set engine starter engages and rotates the engine, but the engine does not start.



- b. The generator set engine starter cranks for 8 seconds, rests for 15 seconds, and cranks another 8 seconds if the generator set control has not verified the information it is monitoring. Depending on the outcome of this sequence, either a shutdown fault message is issued or normal standby operation resumes.

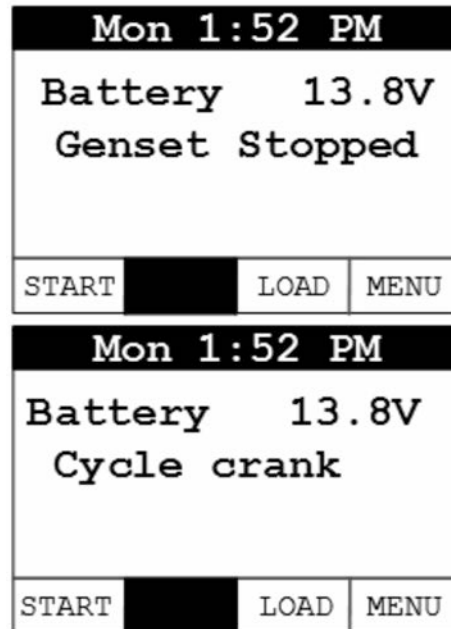


FIGURE 24. CYCLE CRANK

## 4.4 Manual Start Sequence (Local)

NOTICE
<p>If the utility power supply to the generator set's utility powered battery charger is interrupted, the battery can become discharged due to parasitic loads and the generator set may not start when needed. Whenever utility power is interrupted and the generator set is not in Standby mode for any reason (fuel preservation, etc.), start and run the generator set for 2 hours every 24 hour period when temperatures are <i>above</i> 50 °F (10 °C), or every 9 hour period when temperatures are <i>below</i> 50 °F (10 °C).</p>

The following steps will be executed when Manual Start is used at the local display:

1. If you do not want the ATS to transfer load to the generator set, open the generator set mounted circuit breaker when doing a manual start.
2. From the Main screen, select the **START** key.
3. A second screen appears notifying the operator that Standby will be disabled. Select the **START** key again to start the generator set.

4. After the generator set reaches rated voltage and frequency, the transfer switch transfers the building load to the generator set (unless the circuit breaker on the generator set is "off"). The building's electrical power is now provided by the generator set.

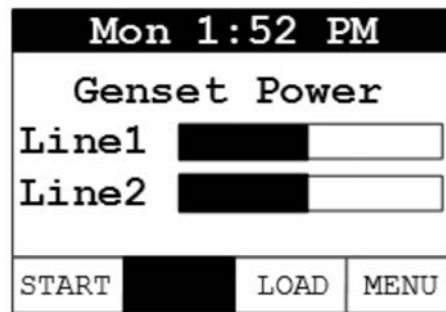


FIGURE 25. GENSET POWER

## 4.5 Manual Stop Sequence (Local)

The following steps will be executed when Manual Stop is selected at the Local display:

1. Press the red **STOP** button on the local display. The generator set will stop immediately and the building load will be transferred to the utility.
2. For normal operation to resume, Standby will need to be enabled. See the section on enabling Standby Mode.

### NOTICE

The red **STOP** button on the Local display, when pressed, will cause both Remote and Standby Modes to be disabled.

## 4.6 Manual Start/Stop Sequence (Remote)

Remote mode must be enabled on the local display to allow manual start and stop from the Remote display. The manual start and stop sequences are the same for the Remote display and the Local display.

### NOTICE

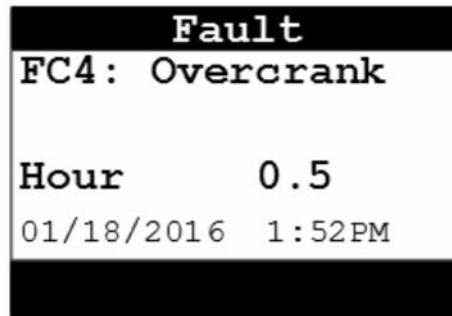
The red **STOP** button on the Remote display, when pressed, will cause the Standby Mode to be disabled.

## 4.7 "Fault" and "New Event" Screens

Various fault and event screens may appear on the operator display.

### "FAULT" SCREEN

If a generator set fault occurs that will stop the generator set, the red FAULT light illuminates and a Fault message appears. The screen shows the Fault Code (FC) number, a brief description of the fault, current engine hours and the time and date of the fault.



**FIGURE 26. TYPICAL FAULT SCREEN**

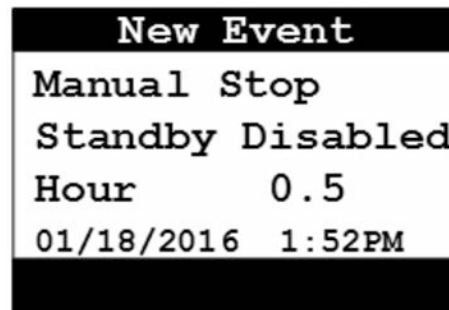
Press the **BACK** button to reset the fault and return to the home screen. The red FAULT light will shut off.

See the "Fault Log" Screen section of this manual for instructions on viewing the log of the last 20 faults.

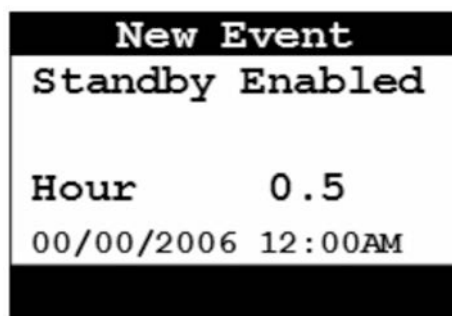
#### **"NEW EVENT" SCREEN**

A New Event screen appears whenever the system status changes. The screen provides a brief description of the event, the current engine hours, and the date and time of the event. The message remains displayed unless superseded by a new event, or the **BACK** button is pressed.

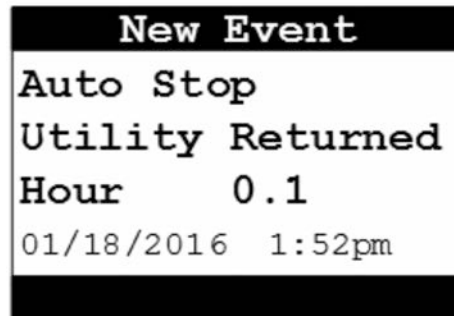
##### 1. Operation Events:



**FIGURE 27. MANUAL STOP – STANDBY DISABLED**

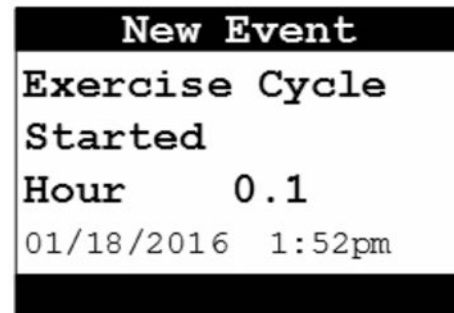


**FIGURE 28. STANDBY ENABLED**



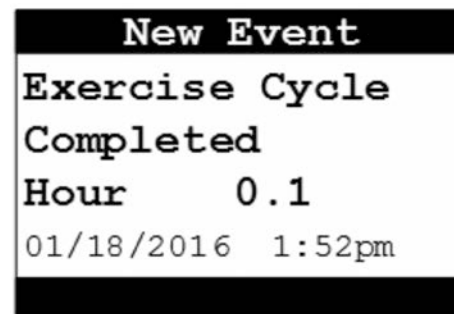
**New Event**  
 Auto Stop  
 Utility Returned  
 Hour 0.1  
 01/18/2016 1:52pm

FIGURE 29. AUTO STOP – UTILITY RETURNED



**New Event**  
 Exercise Cycle  
 Started  
 Hour 0.1  
 01/18/2016 1:52pm

FIGURE 30. EXERCISE CYCLE STARTED



**New Event**  
 Exercise Cycle  
 Completed  
 Hour 0.1  
 01/18/2016 1:52pm

FIGURE 31. EXERCISE CYCLE COMPLETED

## 2. Maintenance and Service Events:

**NOTICE**

When a maintenance or service event occurs, the New Event screen will display and the display's yellow service light will turn on.

<b>NOTICE</b>
Refer to the Periodic Maintenance Schedule section for more information.

```

New Event
Scheduled Maint
See Manual
Hour    300.0
01/18/2016  1:52PM
  
```

**FIGURE 32. SCHEDULED MAINTENANCE REMINDER EXAMPLE**

```

New Event
Warning: Low
Battery Voltage
Hour    0.5
01/18/2016  1:52PM
  
```

**FIGURE 33. LOW BATTERY VOLTAGE WARNING**

```

New Event
Warning:
Low Oil Level
Hour    0.5
01/18/2016  1:52PM
  
```

**FIGURE 34. LOW OIL LEVEL WARNING**

Press the **BACK** button to return to the home screen and turn off the light (if lit).

See the "Event Log" Screen section of this manual for instructions on viewing the list of the last 20 events.

This page is intentionally blank.

# 5 Maintenance

---

## 5.1 Maintenance Safety

 **WARNING**

**Automated Machinery**

***Accidental or remote starting of the generator set can cause severe personal injury or death.***

***Isolate all auxiliary supplies and use an insulated wrench to disconnect the starting battery cables (negative [-] first).***

 **WARNING**

**Hydrogen Gas**

***Arcing can ignite explosive hydrogen gas given off by batteries, causing severe personal injury or death. Arcing can occur when cables are removed or replaced, or when the negative (-) battery cable is connected and a tool used to connect or disconnect the positive (+) battery cable touches the frame or other grounded metal part of the generator set.***

***Insulated tools must be used when working in the vicinity of the batteries. Always remove the negative (-) cable first and reconnect last.***

 **WARNING**

**Explosive Fumes**

***Arcing can ignite explosive fumes causing severe personal injury or death.***

***Make sure hydrogen from the battery, engine fuel and other explosive fumes are fully dissipated before working on the generator set.***

 **WARNING**

**Working at Heights**

***Using the incorrect equipment when working at heights can result in severe personal injury or death.***

***Suitable equipment for performing these tasks must be used in accordance with the local guidelines and legislation. Failure to follow these instructions can result in severe personal injury or death.***

**⚠ WARNING****Access**

***Using the generator set or part of as a means of access when attaching lifting shackles, chains, or other lifting aids, may damage the generator set, causing severe personal injury or death.***

***Do not use the generator set as a means of access. Failure to follow these instructions can result in severe personal injury or death.***

**⚠ WARNING****Exposed Terminations**

***Some panel internal components may have live exposed terminations even if the generator set is not running. Voltages are present which can cause electrical shock, resulting in personal injury or damage to equipment.***

***Isolate all external electrical supplies prior to access of the control panel***

**NOTICE**

**Only authorized and qualified maintenance technicians who are familiar with the equipment and its operation should carry out maintenance.**

**NOTICE**

**Dependent upon the control system fitted, this unit may operate automatically and could start without warning.**

**NOTICE**

**Always disconnect a battery charger from its AC source before disconnecting the battery cables. Failure to do so can result in voltage spikes high enough to damage the DC control circuits of the generator set.**

All maintenance tasks must be performed, but be sure to assess them for health and safety risks before starting. For example, perform a task with someone present if doing so will add significantly to the safety of the task.

Read, understand, and comply with all Caution, Warning, and Danger notes in this section, the Important Safety Instructions section, and the documentation supplied with the generator set.

Make sure that adequate lighting is available.



## Locking the Generator Set Out of Service

### NOTICE

#### Automated Machinery

Accidental or remote starting of the generator set can cause severe personal injury or death.

Isolate all auxiliary supplies and use an insulated wrench to disconnect the starting battery cables, negative (–) cable first.

Before any work is carried out for maintenance, etc., the generator set must be immobilized. Even if the generator set is put out of service by pressing the Off switch on the Operator Panel (or the STOP button if applicable), the generator set cannot be considered safe to work on until the engine is properly immobilized, as detailed in the following procedure.


### NOTICE

Refer also to the engine-specific Operator Manual, if applicable. This manual contains specific equipment instructions that may differ from the standard generator set.

To immobilize the generator set:

1. Press the Off switch from the display and then press the E-Stop button to shut down the engine. This will prevent the starting of the generator set regardless of the Start signal source and will therefore provide an additional safety step for immobilizing the generator set. Alternatively, make sure the generator set is in manual mode (which allows it to be started by manually pushing the buttons).

### NOTICE

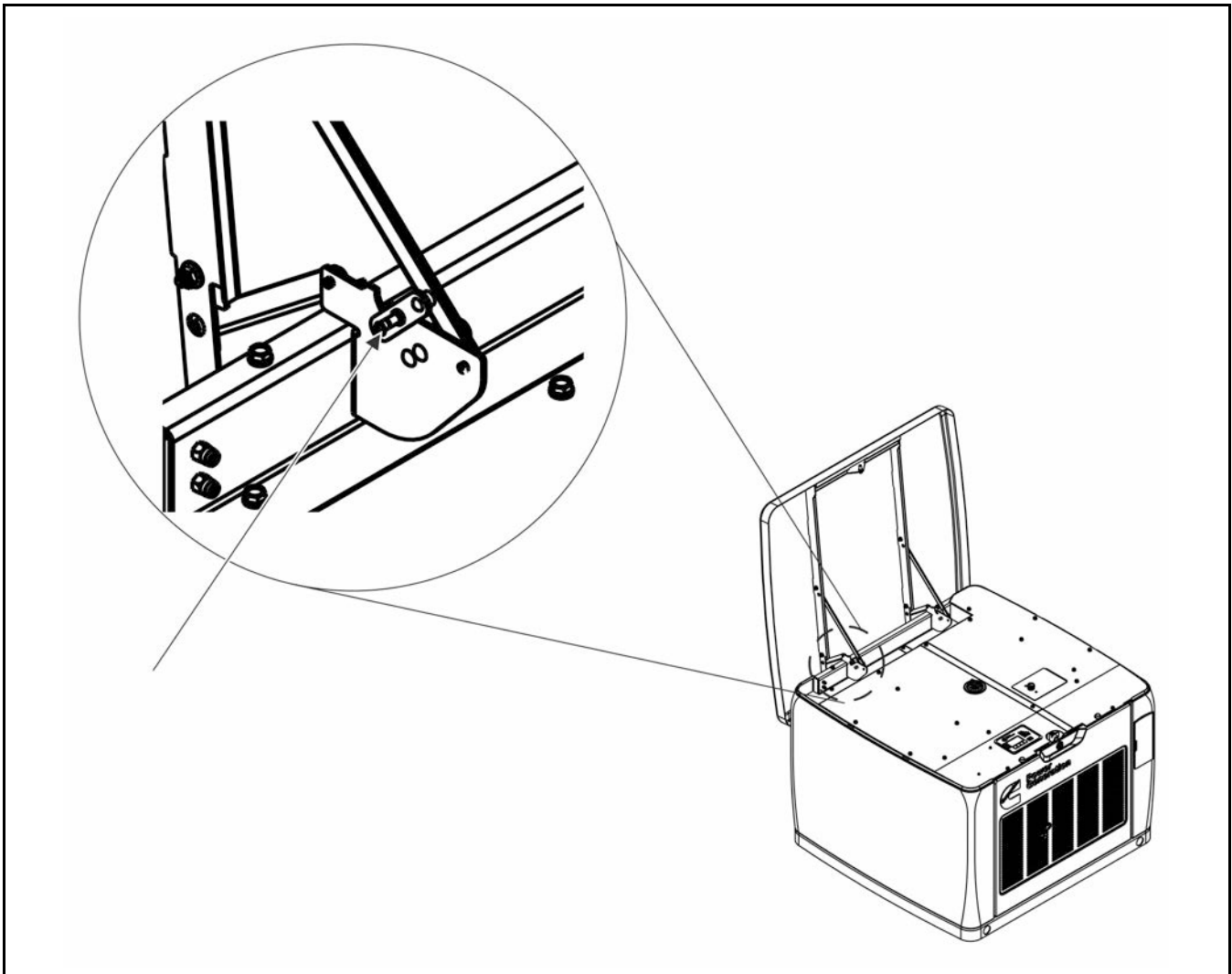
When the E-Stop button is pressed, the Operator Panel indicates the Shutdown condition by illuminating the red Shutdown status LED  and displaying a message on the graphical LCD display.

2. Thoroughly ventilate the generator set before disconnecting any leads.
3. Turn off and disconnect the heater (where fitted) from the AC source before disconnecting the battery cables.
4. Turn off and disconnect the battery charger (where fitted) from the AC source before disconnecting the battery cables.
5. Turn off the fuel supply to the engine.
6. Disconnect the battery. Disconnect the negative (–) cable first, using an insulated wrench.
7. Place warning notices at each of the above locations that state, "Maintenance in Progress – Immobilized for Safe Working."

## Operating the Generator Set Cover Safely

To configure the local display or access the generator set, you will need to lift the cover (lid). The cover of the generator set is designed to latch securely into the "up" position to prevent accidental closure.

- *To open:* Lift the cover until the hinge pin drops into the hinge pin slot. Test that the cover is secure by gently pressing down on the cover.
- *To close:* Lift up on the cover while pressing upward on the hinge pin and slide the pin upwards out of the hinge pin slot. Carefully push the cover downward and let go of the hinge pin allowing it to ride along the hinge until the cover is closed.



**FIGURE 35. HINGE LOCATION**

## 5.2 Periodic Maintenance

 **WARNING**

***Electrical Generating Equipment***

***Accidental or remote starting of the generator set can cause severe personal injury or death.***

***Before working on the generator set, make sure that the generator set is in Off mode, disable the battery charger, and remove the negative (-) battery cable from the battery to prevent starting.***

The table(s) that follow show the recommended service intervals for a generator set on standby service. If the generator set will be subjected to extreme operating conditions, the service intervals should be reduced accordingly.

At each scheduled maintenance interval, perform all previous maintenance checks that are due for scheduled maintenance.

Some of the factors that can affect the maintenance schedule are:

- Extremes in ambient temperature
- Exposure to elements
- Exposure to salt water
- Exposure to windblown dust or sand

Consult with your authorized Cummins Inc. service provider if the generator set will be subjected to any extreme operating conditions, and determine if extra protection or a reduction in service intervals is needed. Use the engine hours shown on the system status screen to keep an accurate log of all service performed for warranty support. Perform all service at the time period indicated, or after the number of operating hours indicated, whichever comes first.

Repair or replace worn, damaged, or improperly functioning components identified during periodic maintenance procedures.

### Periodic Maintenance Guidelines

Regularly performing the following periodic maintenance tasks greatly reduces the chances of a generator set shutdown:

- Maintain an appropriate oil level.
- Keep battery connections clean and tight.
- Do not overload the generator set.
- Keep the air inlet and outlet openings clear.

## Periodic Maintenance Schedule

Periodic maintenance is essential for top generator set performance. Use the Maintenance Frequency table below as a guide for normal periodic maintenance.

- In hot and dusty environments, some maintenance procedures should be performed more frequently, as indicated by the footnotes in the table.
- Maintenance, replacement or repair of emission control devices and systems may be performed by any engine repair establishment or individual.
  - Warranty work **MUST** be completed by your authorized Cummins Inc. service provider.

### WARNING

**Automatic startup of the generator set can cause severe personal injury or death. Make sure the generator set is shut down and disabled:**

- 1. Press the generator set's red STOP button on the local display to stop the generator set. Allow the generator set to thoroughly cool to the touch.**
- 2. Turn off and disconnect the battery charger from the AC source before disconnecting the battery cables.**
- 3. Disconnect the negative (-) cable from the battery and secure it from contacting the battery terminals to prevent accidental starting.**

### NOTICE

**Perform all service at the time period indicated, or after the number of operating hours indicated, whichever comes first.**

TABLE 11. MAINTENANCE FREQUENCY

Maintenance Task	Maintenance Frequency (Running Time)			Every 2 Years
	First 25 Hours and 100 Hours	Every 24 Hours	Every 200 Hours	
Check Engine Oil Level		■ <sup>2, 3</sup>		
Change Engine Oil and Oil Filter	■		■ <sup>4</sup>	■ <sup>4</sup>
Adjust Engine Valve Clearance	■ <sup>1, 6</sup>		■ <sup>1, 6</sup>	
Replace Engine Air Filter			■ <sup>4</sup>	■ <sup>4</sup>
Clean and Check Starting Battery			■	
Complete System Test			■ <sup>5, 6</sup>	■ <sup>5, 6</sup>

Maintenance Task	Maintenance Frequency (Running Time)			Every 2 Years
	First 25 Hours and 100 Hours	Every 24 Hours	Every 200 Hours	
<ol style="list-style-type: none"> <li>1. Perform sooner if engine performance deteriorates.</li> <li>2. Perform more often when operating in high temperature conditions.</li> <li>3. Check daily during power outages, or monthly without power outages.</li> <li>4. Perform more often when operating in dusty conditions.</li> <li>5. See the automatic transfer switch manual for testing of load transfer.</li> <li>6. Must be performed by a qualified service technician (authorized Cummins Inc. service provider).</li> </ol>				

A "New Event" screen appears and the yellow service LED turns on whenever one of the following scheduled maintenance time periods occurs:

1. First 25 hours of generator set running
2. First 100 hours of generator set running
3. After the first 100 hours, every 200 hours of generator set running

Press the **BACK** button to turn off the light and return to the home screen.

See the "Fault" and "New Event" Screens section for more information.

## 5.3 Engine Oil

### Recommended Engine Oil

Check the oil level prior to starting the generator set to verify that the oil level is between the High and Low marks.

The generator set is shipped with 0W30 synthetic engine oil. Refer to the Model Specification section for the oil specification.

### Checking Engine Oil Level

#### WARNING

***State and federal agencies have determined that contact with used engine oil can cause cancer or reproductive toxicity. Avoid skin contact and breathing of vapors. Use rubber gloves and wash exposed skin.***

**⚠ WARNING*****Automated Machinery***

***Accidental or remote starting of the generator set can cause severe personal injury or death.***

***The generator set must be off and locked out of service whenever the air inlet, air outlet, or any interior panels, are removed.***

**⚠ WARNING**

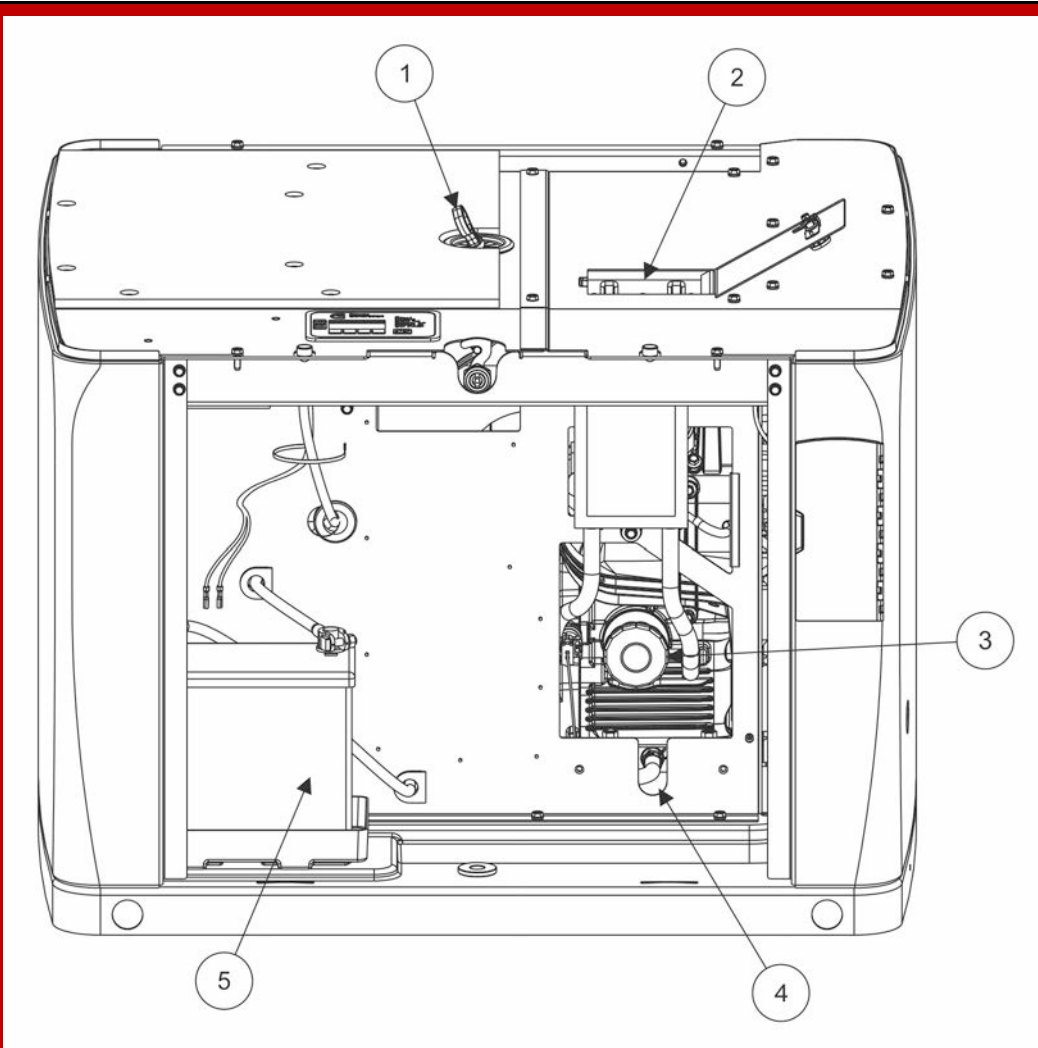
***Crankcase pressure can blow out hot oil and cause severe burns. Do NOT check oil while the generator set is operating.***

**NOTICE**

**Check the engine oil level when the generator set is not running and is out of Remote mode.**

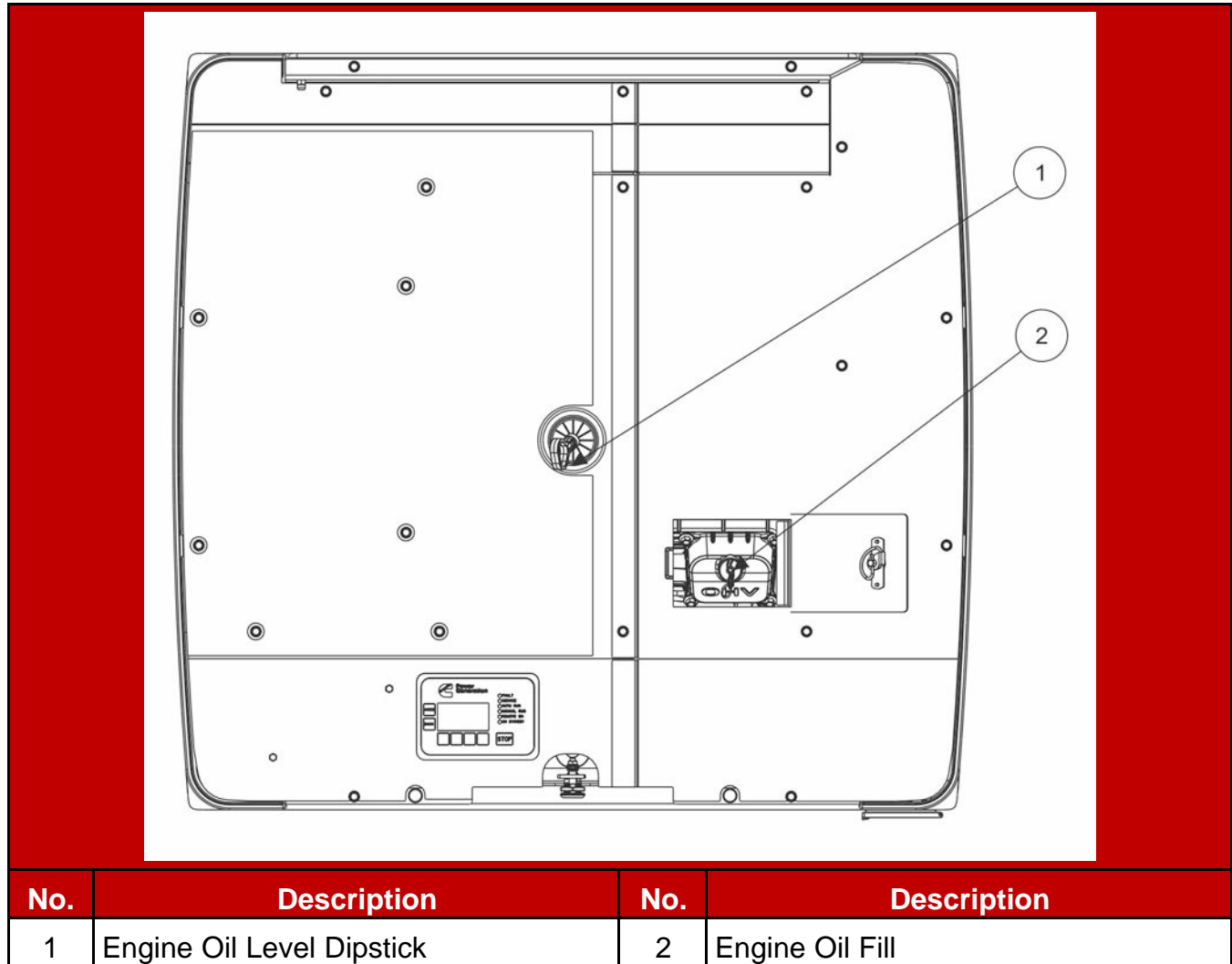
**NOTICE**

**Overfilling can cause foaming or aeration of the oil, and operation below the low mark may cause loss of oil pressure. Do not operate the generator set with the oil level below the low mark or above the high mark.**



No.	Description	No.	Description
1	Engine Oil Level Dipstick	4	Engine Oil Drain Hose
2	Engine Oil Fill	5	Battery
3	Engine Oil Filter		

**FIGURE 36. ENGINE OIL COMPONENTS (SIDE VIEW)**



**FIGURE 37. ENGINE OIL COMPONENTS (TOP VIEW)**

To check the engine oil level:

1. Make sure that the generator set has not been running for approximately five minutes.
2. Clean off the area surrounding the dipstick port and prevent debris from entering the engine.
3. Pull out the dipstick and wipe it clean.
4. Reinsert and fully seat the dipstick.
5. Remove the dipstick and check the oil level.
6. Reinsert and fully seat the dipstick.

If the engine oil level check shows excessive or insufficient levels of oil (oil level line above the High mark or below the Low mark), oil must be drained or added. Refer to the following sections for instructions and guidelines for draining and adding oil.



## Adding or Draining Oil

### WARNING

#### **Hot Surfaces**

**Contact with hot surfaces can cause severe burns. Wear appropriate PPE when working on hot equipment and avoid physical contact with hot surfaces.**

### WARNING

#### **Hot Engines**

**Contact with hot engines can cause severe burns. Ensure that the generator set engine has cooled down before adding or draining the oil.**

### NOTICE

**Too much oil can cause high oil consumption. Too little oil can cause severe engine damage. Keep the oil level between the High and Low marks on the dipstick.**

## Adding Oil

If the oil level is found to be insufficient, oil must be added.

1. Ensure that the oil fill cap area is clean, and prevent debris from entering the engine.
2. Add the appropriate amount of oil, based on the engine oil level check. Refer to the Checking Engine Oil Level section and the Model Specifications section.
3. Recheck the engine oil level. Based on the results, add or drain oil.
4. Clean up and dispose of any oil in accordance with local/state regulations.

## Draining Excessive Oil

If the oil level is found to be excessive, oil must first be drained from the engine.

1. Remove the access panels to get to the drain hose.
2. Place the end of the drain hose into an appropriate container.

### NOTICE

**Refer to local regulations to determine the appropriate container for used oil.**

3. Open the oil drain cap to release oil from the engine into the appropriate container.
4. Re-check the engine oil level. Based on the results, add or drain oil.

5. When a sufficient amount of oil has been drained from the system, close the oil drain cap.
6. Wipe the oil drain cap clean.
7. Re-install the access panels. Torque the fasteners 3.5 - 5.0 ft-lb (5.0 - 6.6 Nm).
8. Dispose of the used oil in accordance with local and state regulations.

## Changing Engine Oil and Oil Filter

### NOTICE

#### Automated Machinery

Accidental or remote starting of the generator set can cause severe personal injury or death.

Isolate all auxiliary supplies and use an insulated wrench to disconnect the starting battery cables, negative (–) cable first.

### ⚠ WARNING

#### Toxic Hazard

State and federal agencies have determined that contact with used engine oil can cause cancer or reproductive toxicity.

Avoid skin contact and breathing of vapors. Use rubber gloves and wash exposed skin.

### NOTICE

If the oil and/or oil filter are not reused, dispose of them in accordance with local environmental regulations.

### NOTICE

Change the engine oil and filter when the generator set is not running and is out of Remote mode.

### NOTICE

Change the oil more often in hot and dusty environments.

### NOTICE

Cummins highly recommends that any service or maintenance work be performed by qualified technicians.

1. Open the generator set's circuit breaker to prevent the ATS from transferring to generator set source when manually starting.
2. Before changing the oil, manually start the generator set.
3. Allow the generator set to run for 2 to 5 minutes to warm the engine oil.

4. Remove the access panels to get to the drain hose.
5. Make sure the generator set is shut down and disabled:
  - a. Press the generator set's "O" (Off) button to stop the generator set. Allow the generator set to thoroughly cool to the touch.
  - b. If applicable, turn off and disconnect the battery charger from the AC source before disconnecting the battery cables.
  - c. Disconnect the negative (–) cable from the battery and secure it from contacting the battery terminals to prevent accidental starting.
6. Open the oil drain cap to release oil from the engine into the appropriate container.

**NOTICE**

**Refer to local regulations to determine the appropriate container for used oil.**

7. Close the oil drain cap.
8. Wipe the oil drain cap clean.
9. Place an appropriate container below the oil filter to collect oil as the filter is being removed.
10. Remove the oil filter by turning it counterclockwise.
11. Remove the old gasket if it remains on the engine.
12. Clean the filter mounting surface on the engine block.
13. Make sure the gasket is in place on the new filter and apply a thin film of clean oil to the gasket.
14. Install the new filter until the gasket just touches the block. Turn it an additional 1/2 to 3/4 turn. Do not over-tighten.
15. Remove the container used to collect oil when removing the oil filter.
16. Add the appropriate amount of oil.

**NOTICE**

**Too much oil can cause high oil consumption. Too little oil can cause severe engine damage. Keep the oil level between the High and Low marks.**

17. Check the engine oil level. Based on the results, add or drain oil.
18. Remove any oil that has spilled on the generator set during this procedure.
19. Make sure the generator set breaker is open.
20. Reconnect the cables and battery charger:
  - a. Reconnect the engine battery cables, positive (+) cable first.
  - b. Reconnect the battery charger to its AC power source.

21. Operate the generator set with no load for approximately 5 minutes to check for leaks at the oil filter or oil drain hose.
22. Shut down the generator set, wait 5 minutes, and then confirm that the correct oil level is in the pan.
23. Check for leaks and repair any that are identified.
24. Dispose of the used oil and oil filter according to local environmental regulations.
25. Re-install the access panels. Torque the fasteners 5.0 - 6.6 Nm (3.5 - 5.0 ft-lb).
26. Restore the original generator set settings.
27. Close the generator set breaker.

## 5.4 Exhaust System Maintenance

 **WARNING**

***Hot Exhaust Components***

***Exhaust components become very hot when the generator set is in use and remain hot for a period of time after the generator set has been shut down. These components can cause severe personal injury or death from contact. Allow these components to cool completely before performing any maintenance tasks.***

 **WARNING**

***Inhalation of Exhaust Gases***

***Inhalation of exhaust gases can result in serious personal injury or death. Be sure deadly exhaust gas is piped outside and away from windows, doors or other inlets to buildings. Do not allow to accumulate in habitable areas.***

 **WARNING**

***Moving Parts.***

***Moving parts can cause severe personal injury or death. Use extreme caution around moving parts, etc.***

With the generator set operating, inspect the entire exhaust system visually and audibly including the exhaust manifold, muffler, and exhaust pipe without removing guarding and panels. Check for leaks at all connections, welds, gaskets and joints, and ensure that exhaust pipes are not heating surrounding areas excessively. If any leaks are detected, shut down the generator set (if possible). Contact your authorized dealer and have the leaks corrected immediately.

## 5.5 DC Electrical System

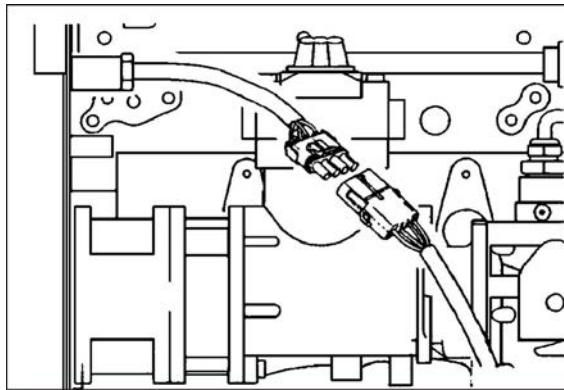
### WARNING

#### **Combustible Gases**

***Ignition of battery gases is a fire and explosion hazard which can cause severe personal injury or death.***

***Do not smoke, or switch the trouble light ON or OFF near a battery. Touch a grounded metal surface first before touching batteries to discharge static electricity. Stop the generator set and disconnect the battery charger before disconnecting battery cables. Using an insulated wrench, disconnect the negative (-) cable first and reconnect it last.***

1. Check the harness connections. If any harness connections are damaged, contact your service representative.



**FIGURE 38. CHECK HARNESS CONNECTIONS**

2. Check the terminals on the batteries for clean and tight connections. Loose or corroded connections create resistance, which can hinder starting. Clean and reconnect the battery cables if loose, using an insulated wrench. Always disconnect both ends of the negative battery cable. Reconnect one end of the cable to the negative battery terminal and the other end to ground. This will make sure that any arcing will be away from the battery and least likely to ignite explosive battery gases.
3. Check connections at the battery charging alternator.
4. Visually inspect the alternator belt to make sure it is not loose or cracked.

## 5.6 Batteries

Batteries are an essential part of any standby generator set system. A significant amount of generator set failures are due to battery issues.

It is therefore vital that batteries are stored, commissioned, and maintained as detailed here. Reference should also be made to the battery manufacturer's instructions.

Maintenance free batteries (if supplied with the generator set) need no maintenance for commissioning.

## Storage

Batteries must be stored in a cool, dry, well-ventilated place, in the upright position, and with the vent caps securely in place.

Batteries must never be stacked on top of each other and must be protected from the floor by a wooden pallet or suitably thick cardboard sheet.

## General Precautions for Maintenance-Free Batteries

Handling and proper use of batteries is not hazardous if the correct precautions are observed and personnel are trained in their use.

### WARNING

#### ***Arcing Hazard***

***Laying tools or metal objects across the battery can cause arcing that may ignite battery gases causing explosions resulting in personal injury.  
Never lay tools or metal objects across the top of the battery.***

### WARNING

#### ***Electric Shock Hazard***

***Voltages and currents present an electrical shock hazard that can cause severe burns or death.  
Use tools with insulated handles to prevent the risk of electric shock.***

### CAUTION

#### ***Toxic Hazard***

***Electrolyte is a dilute sulphuric acid that is harmful to the skin and eyes. It is electrically conductive and corrosive.***

***Wear full eye protection and protective clothing. If electrolyte contacts the skins, wash it off immediately with water. If electrolyte contacts the eyes, flush thoroughly and immediately with water and seek medical attention.  
Wash spilled electrolyte with an acid neutralizing agent.***

### NOTICE

**Keep batteries upright to prevent spillage.**

## Fire Hazard

### WARNING

#### **Combustible Gases**

**Lead acid batteries present a risk of fire because they generate hydrogen gas.**

**Do not smoke near the batteries. Do not cause flame or spark in the battery area. Discharge static electricity from your body before touching batteries by first touching a grounded metal surface.**

### WARNING

**Before disconnecting a battery, always remove power from the AC powered battery charger.**

### WARNING

**When putting a battery into service on a generator set, connect the negative lead LAST; when removing the battery, disconnect the negative lead FIRST.**

## Vented Batteries

### WARNING

#### **Toxic Hazard**

**The electrolyte in vented batteries is a dilute sulfuric acid that is harmful to the skin and eyes. It is also electrically conductive and corrosive.**

**Always:**

- 1. Wear full eye protection and protective clothing;**
- 2. If the electrolyte contacts the skin, wash it off immediately with water;**
- 3. If the electrolyte contacts the eyes, flush them thoroughly and immediately with water and seek medical attention; and**
- 4. Wash spilled electrolyte down with an acid neutralizing agent. A common practice is to use a solution of one pound (500 grams) bicarbonate of soda (also known as baking soda or sodium bicarbonate) to one gallon (4 liters) of water.**
- 5. Continue to add the bicarbonate of soda solution until the evidence of reaction (that is, foaming) has stopped.**
- 6. Flush the resulting liquid with water and dry the area.**

## Battery Maintenance

### WARNING

#### ***Automated Machinery***

***Accidental or remote starting of the generator set can cause severe personal injury or death. Arcing at battery terminals or in light switches or other equipment, and flames or sparks can ignite battery gas causing severe personal injury.***

***Always follow these procedures to avoid injury and/or damage:***

- ***Ventilate the battery area before working on or near the battery.***
- ***Wear safety glasses.***
- ***Do not smoke.***
- ***Switch a work light on or off away from the battery.***

***Make sure the generator set is shut down and disabled:***

1. ***Press the generator set's red STOP button on the local display to stop the generator set. Allow the generator set to thoroughly cool to the touch.***
2. ***Turn off and disconnect the battery charger from the AC source before disconnecting the battery cables.***
3. ***Disconnect the negative (-) cable from the battery and secure it from contacting the battery terminals to prevent accidental starting.***
4. ***Once work is complete, reconnect the negative (-) battery cable last.***

Replace the battery charger if the battery keeps running down.

Always:

- Keep the battery case and terminals clean and dry and the terminals tight.
- Remove battery cables with an insulated wrench or battery terminal puller.
- Make sure which terminal is positive (+) and which is negative (-) before making battery connections, always removing the negative (-) cable first and reconnecting it last to reduce arcing.

### NOTICE

**If the battery needs to be replaced, make sure that the replacement battery specifications match those found in the Model Specifications in this manual.**

## Charging

Where a consistent source of AC power is available, Cummins recommends the use of a battery charger to maintain battery condition and charge. Cummins offers several battery chargers.



Where generator sets are used infrequently and a consistent source of AC power is not available, battery recharging must be put on a monthly recharge schedule to ensure that a fully charged condition is maintained.

**NOTICE**

**NEVER allow a battery to become completely flat (fully discharged), or to stand in a discharged condition, or damage will result.**

Follow the battery charger operating instructions for proper use.

## Battery Replacement

**⚠ WARNING*****Combustible Liquid***

***Burning the battery may cause an explosion. Damage to the casing will release electrolytes which is harmful to the skin and eyes.***

***When disposing of a battery, do not mutilate or burn it. Comply with all local health and safety regulations/codes during handling or disposal.***

Always replace the starting battery with the same number and type (e.g., vented, lead acid, maintenance free) as listed in the specifications section of this document. Properly dispose of battery in accordance with local environment agency requirements.

Always use correct handling techniques to lift and move a battery.

## 5.7 Spark Plugs

Spark plugs are designed to last the useful life of the generator set. If a spark plug malfunction is suspected, remove and inspect the condition of each spark plug. Check for excessive corrosion, oil accumulation and soot deposits. Refer to the Model Specifications section for spark plug torque.

## 5.8 Cleaning the Generator Set Housing

The housing of the generator set housing can be damaged by pressure washing or solvents and other cleaning agents. Only use soap and water or an "all citrus degreaser" to clean the housing.

## 5.9 Complete System Test

**NOTICE**

**Only authorized and qualified maintenance technicians who are familiar with the equipment and its operation should carry out this test.**

---

A complete system test is recommended to verify that the electrical system is working properly. Testing the system once every 200 hours or every 2 years is required to make sure the transfer switch will transfer the load to the generator set if there is a utility power failure. For more information, see the transfer switch owner manual.

To initiate a complete system test:

1. Before starting:
  - Check the oil level.
  - Make sure there is enough fuel.
  - See the Checklist section in the installation manual.
2. Place the generator set in Standby mode.
3. Switch the main utility disconnect from the ON to the OFF position.
4. Make sure the following occurs:
  - a. The generator set starts.
  - b. After the generator set starts and stabilizes, the load is transferred from the utility to the generator set.
5. Switch the main utility disconnect from the OFF to the ON position.
6. Make sure the following occurs:
  - a. After approximately 5 minutes, the load is transferred back to the utility.
  - b. Once the transfer switch is connected to utility power, after approximately 5 minutes, the generator set stops.

**NOTICE**

**If the test fails, call your authorized Cummins service provider to fix the problem.**

# 6 Service

---

## 6.1 Control System

The generator set control system continuously monitors the engine and the alternator. If an abnormal condition is sensed, either the yellow Service lamp or the red Fault lamp will illuminate and a message will be displayed on the local and remote displays. In the event of a generator set shutdown fault (red Fault LED), the control will stop the generator set immediately.

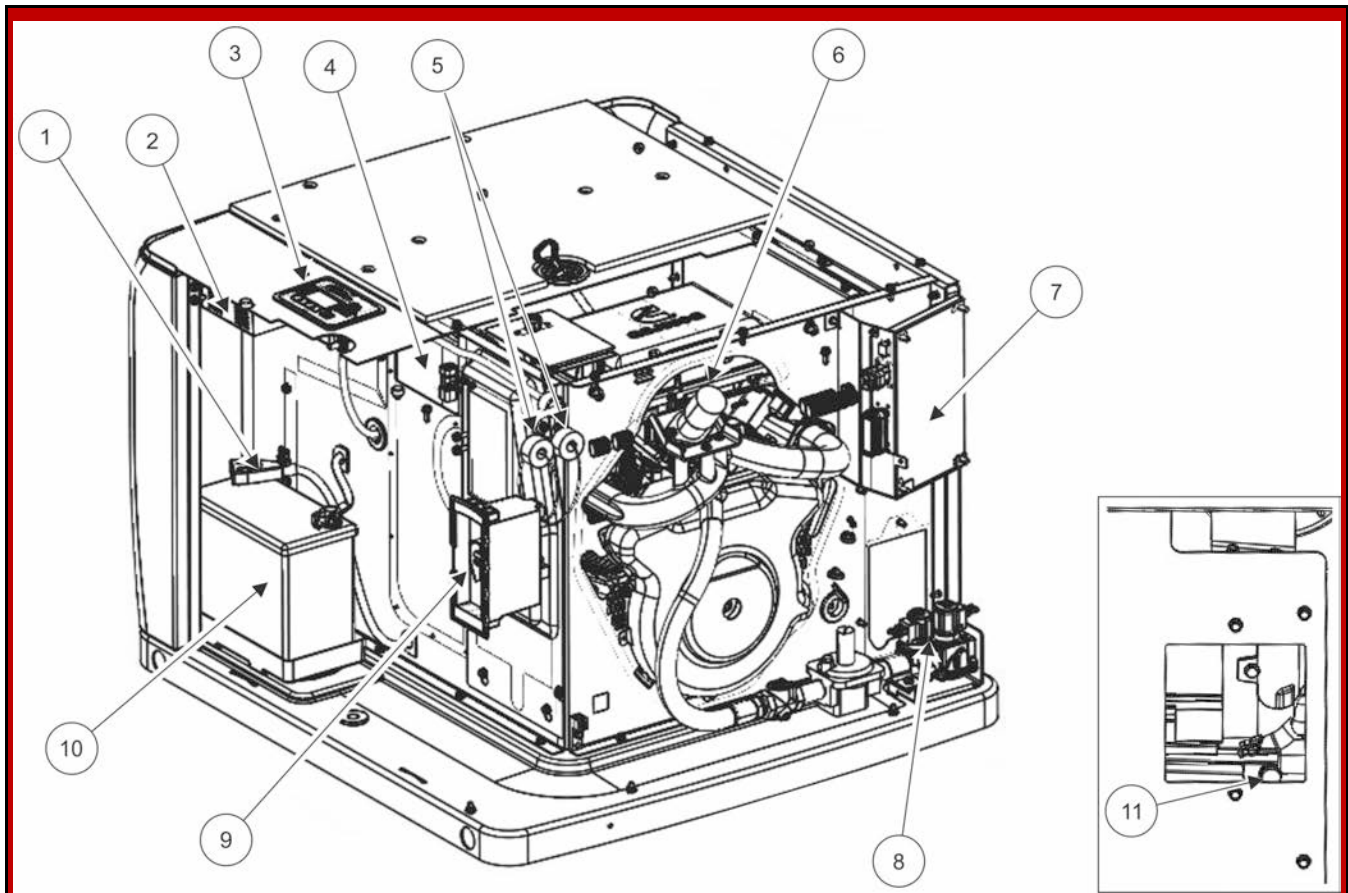
### "Establishing Communications" Message

#### **NOTICE**

Once the battery is connected to the generator set and any display button is pressed, the local display shows an "establishing communications" message for approximately 5 seconds. (This may take longer if the signal integrity is poor between the control and display due to a bad wire or Electro-Magnetic Interference [EMI].) Once communication is established, the display shows the HOME screen.

The "establishing communications" message will also be displayed whenever the control is brought out of "sleep" mode by pressing any button on the display. Sleep mode is entered after 30 minutes without utility or generator set power to preserve battery energy since the battery charger will not have AC power. The 30-minute timer is reset with any button press on the display.

## Control Components



No.	Description	No.	Description
1	B+ Battery Cable	7	Control Board
2	Battery Charger	8	Fuel Shut-Off Valves
3	Local Display	9	Circuit Breaker
4	Oil and Battery Heater Temperature Switch	10	Battery
5	Current Transformers	11	Alternator Temperature Switch
6	Governor Actuator		

**FIGURE 39. CONTROL COMPONENTS**

## Generator Set Control

Type	Description
<b>General</b>	The generator set control is an integrated microcontroller-based engine, alternator and transfer switch control. It provides all the control, monitoring and diagnostic functions required to operate this generator set.
<b>Transfer Switch Control</b>	<p>When a transfer switch without a built-in controller is used, all transfer and retransfer signals come from the generator set control. Transfer times are pre-set and not adjustable:</p> <ul style="list-style-type: none"> <li>• Power transfer delay from the utility to the generator set is set at 1 second.</li> <li>• Retransfer delay back to the utility is set for five minutes. (After retransfer, there is a generator set cool down period of five minutes.)</li> </ul>
<b>Connections</b>	Optional Ethernet connections are through a Cat 5a or 6 Ethernet cable connector. Refer to the appropriate wiring diagrams and wiring harness drawings.
<b>Mounting</b>	The generator set control is mounted on the engine end of the generator set.
<b>Configuration</b>	Perform the instructions in the "Generator Config" Screen section when replacing the control board.
<b>Control Board Replacement</b>	See the Control Board Replacement section.
<b>Control Software Updates</b>	<ol style="list-style-type: none"> <li>1. Disconnect the harness to the local display at J1 before updating the control software. Refer to the appropriate wiring diagrams for more information.</li> <li>2. Connect the InPower Power Generation service tool (PN A044M377) to service connector J5.</li> <li>3. Press the Stop button to wake up the control.</li> <li>4. Connect InPower and update the software.</li> <li>5. Disconnect the service tool harness and reconnect the local display to J1.</li> </ol>

## Display Setup

The HMI Type screen is used to modify the display and user preferences. A display can be set up to be Local or Remote (default = Remote).

 **WARNING*****Automated Machinery***

***When the generator set is in Remote mode, it may start unexpectedly. Accidental or remote starting of the generator set can cause severe personal injury or death.***

***Because any display configured as “Local” can enable the generator set’s Remote mode, make sure that only the display located at the generator set is configured as “Local”.***

To access the HMI Type screen:

1. From the Main screen, select **Menu**.
2. Press and hold the NEXT key down for at least 5 seconds to view the Config Menu.
3. Use the arrow keys to highlight "HMI Type" and click the **Enter** key. The HMI Type screen appears.
4. In the **Display** field, select **Local** or **Remote**.
5. Keep selecting the **Back** button to save the settings and return to the Main screen.

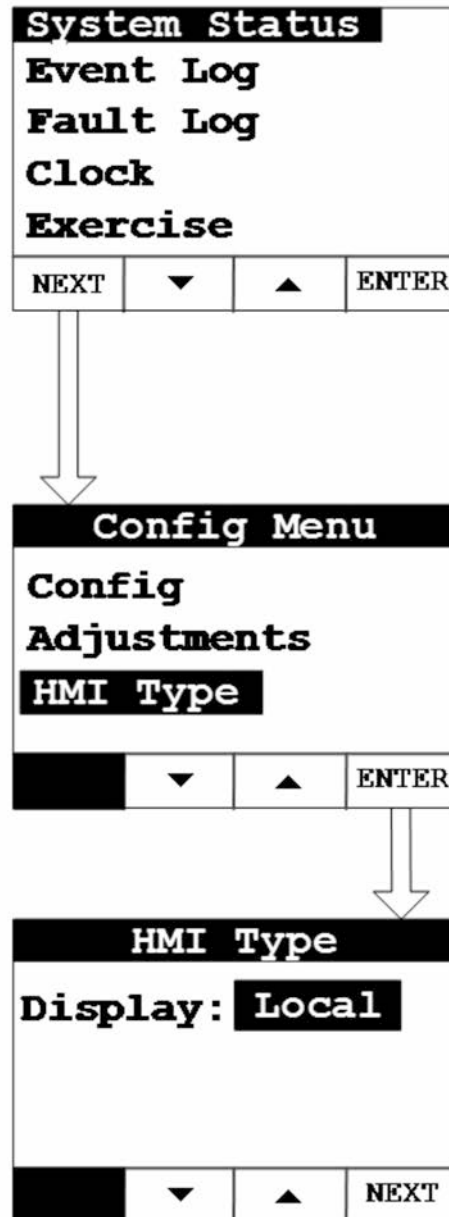


FIGURE 40. DISPLAY SETUP MENU NAVIGATION

## "Generator Config" Screen

The display's Generator Config screen has two generator set parameters (Config and Fuel Type) that must be configured if the control board is replaced or re-configured; failure to do so will result in Fault Code 37. To configure the generator set:

1. From the Main screen, select **Menu**.
2. Press and hold the **Next** key on the Menu screen for at least 5 seconds to view the Config Menu.

3. Use the arrow keys to highlight "Config" and click the **Enter** key. The Generator Config screen appears.
4. The default setting for the **Config** field is 1. Use the **Next** key to navigate to the **Config** field. Use the arrow keys to select the appropriate config option.

Config Option	Model
20	C20N6H, C20N6HC
21	C17N6H
22	C13N6H

5. Use the **Next** key to navigate to the **Fuel Type** field. Use the arrow keys to select the fuel type: NG (natural gas; default) or LP (liquid propane).

**NOTICE**

**The Rating field is not configurable by the user. Instead, it will be automatically populated based on the Config and Fuel Type field selections.**

**NOTICE**

**When converting the generator set to liquid propane, be sure to adjust the manual fuel selector to the LP setting:**

- a. Use a 6 mm external hex wrench to rotate the center section of the fuel valve.
- b. Turn the center section clockwise until the detent is reached.
- c. When you reach the detent, the required force to turn the valve will increase significantly - do not rotate center section of valve beyond this point.

6. Keep selecting the **Back** button to save the settings and return to the Main screen.



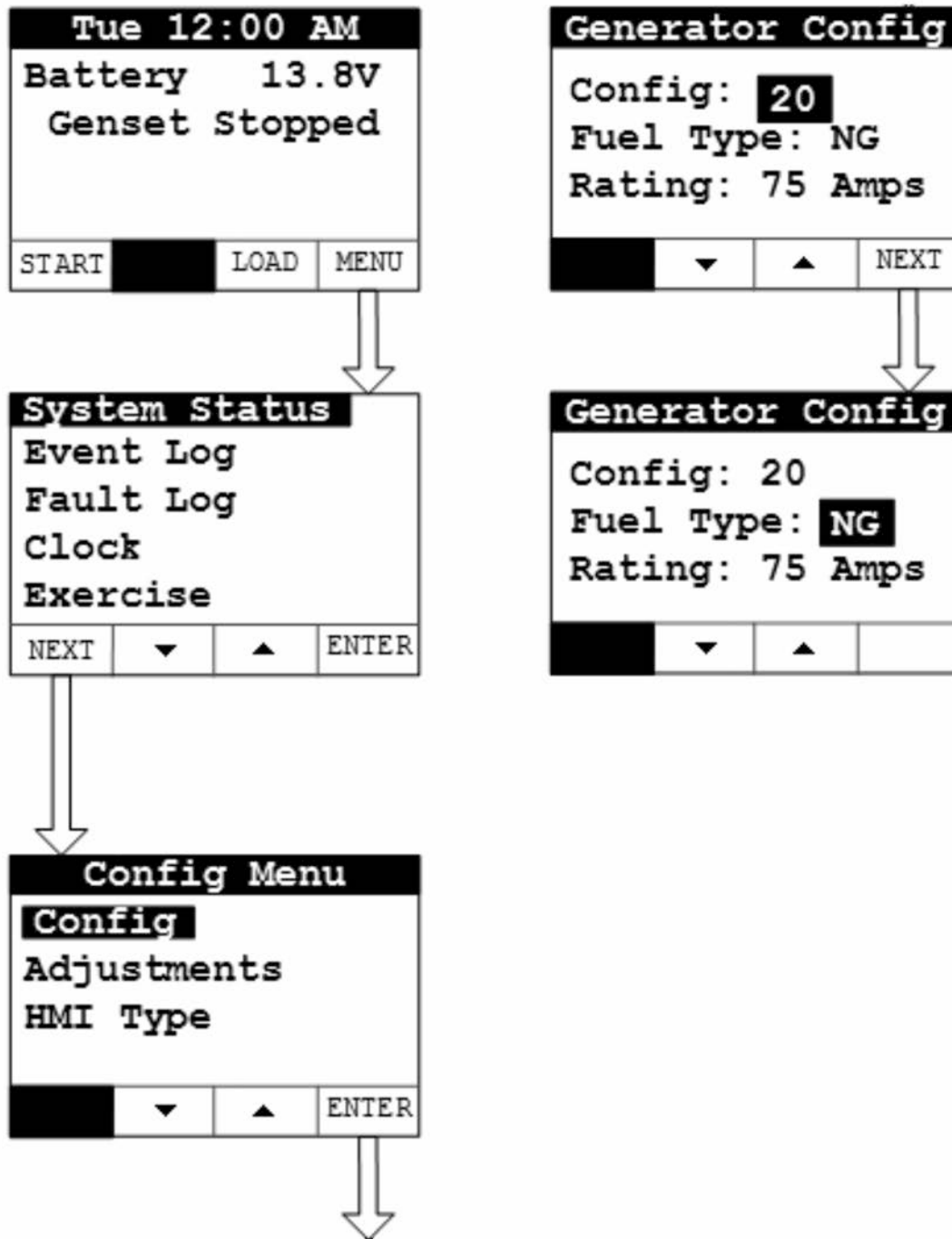


FIGURE 41. GENERATOR CONFIG SCREEN

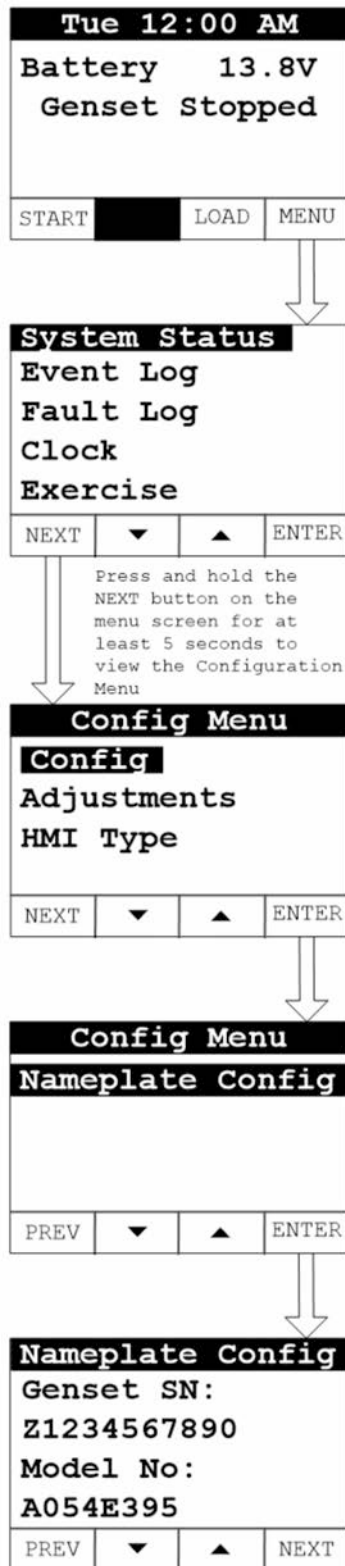
## Control Board Replacement

1. Make sure the generator set is shut down and disabled:
  - a. Press the generator set's red STOP button on the local display to stop the generator set. Allow the generator set to thoroughly cool to the touch.
  - b. Turn off and disconnect the battery charger from the AC source before disconnecting the battery cables.

- 
- c. Disconnect the negative (–) cable from the battery first and secure it from contacting the battery terminals to prevent accidental starting. Then disconnect the positive cable.
  2. Open the hood and make sure the hood latch drops into place.
  3. Remove the control access panel. See the Control Components section for locations.
  4. Remove all wiring harness plugs from the control board, P1, P2, and the optional Ethernet cord.
  5. Remove the bolt retaining the control board.
  6. Remove and replace the control board.
  7. Re-install the 2 wiring harness plugs P1 and P2 only. Do not reconnect the optional Ethernet cord until you have entered the generator set serial number and model number into the control.
  8. Reconnect the generator set battery, positive cable first.
  9. Enter the serial number and product code from the generator set nameplate:
    - a. From the Main screen, select **Menu**.
    - b. Press and hold the **Next** key on the Menu screen for at least five seconds to view the Config Menu.
    - c. Press the **Next** key to get to the next page.
    - d. Highlight “Nameplate Config” and press the **Enter** key.
    - e. Manually enter the serial number and model number from the generator set nameplate.

**NOTICE**

The model number must be in the 8-digit "A054\_###" format.



**FIGURE 42. MENU SCREEN**

10. Set the generator output and fuel type in the Generator Config screen, as described in the Generator Config screen section.

11. *Optional:* Re-install the Ethernet cord into the control.
12. Install the control access panel and close the hood.

**NOTICE**

If the Ethernet cable was plugged in before the serial number and model number were entered, briefly remove and re-install the Ethernet cable from the control or the router, or power-cycle the control.

## 6.2 Fuel System

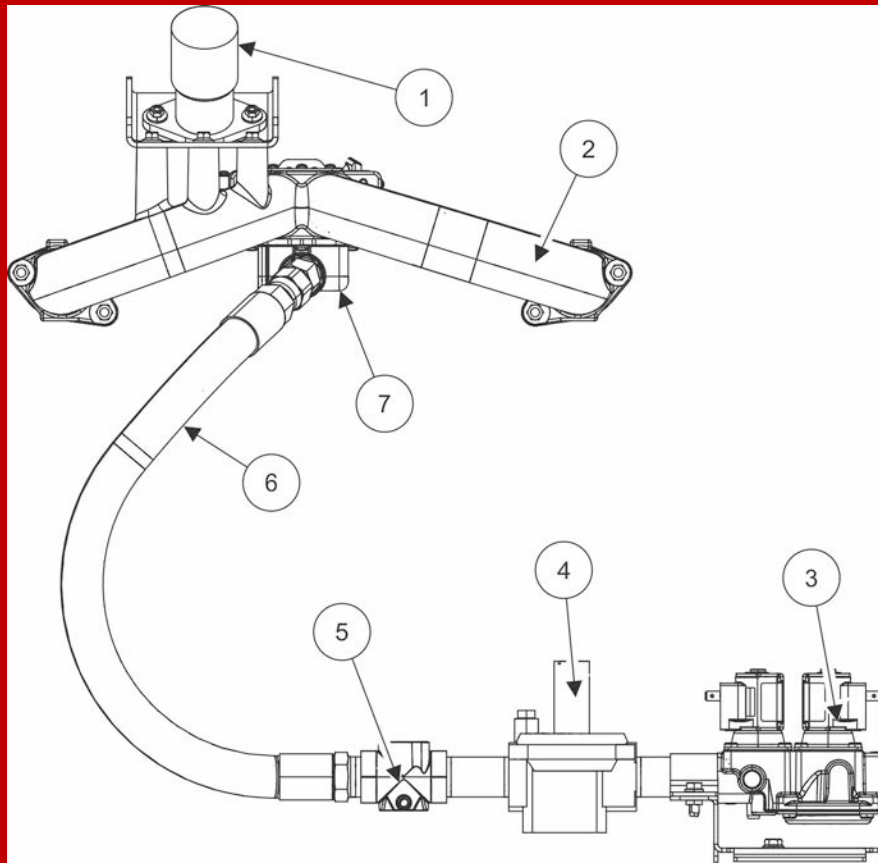
### Fuel System Adjustments

**NOTICE**

Read the warranty statement provided with the generator set for US Environmental Protection Agency (EPA) restrictions on servicing specific components.

### Fuel System Components

The generator set's fuel system consists of the following:

**TABLE 12. FUEL SYSTEM COMPONENTS**

No.	Description	No.	Description
1	Governor Actuator	5	Fuel Select Valve
2	Intake Manifold	6	Fuel Hose
3	Fuel Shutoff Solenoid Valves (2)	7	Air-Fuel Mixer
4	Fuel Pressure Demand Regulator		

### Fuel Pressure Requirements

The minimum pressure refers to supply pressure under rated load (maximum gas flow).

See the Model Specifications section for the maximum permissible fuel supply pressure for propane vapor and natural gas.

---

## Converting the Fuel System Type

The generator set leaves the factory set up for natural gas. For operation on liquid propane vapor, the generator set must be converted by configuring the generator set control for propane and manually changing the fuel valve position from natural gas to propane.

1. To change the generator set control's fuel type from natural gas to liquid propane vapor:
  - a. From the Main screen, select **Menu**.
  - b. Press and hold the **Next** key on the Menu screen for at least 5 seconds to view the Config Menu.
  - c. Use the arrow keys to highlight "Config" and click the **Enter** key. The Generator Config screen appears.
  - d. Use the **Next** key to navigate to the **Fuel Type** field. Use the arrow keys to select the fuel type: NG (natural gas; default) or LP (liquid propane).

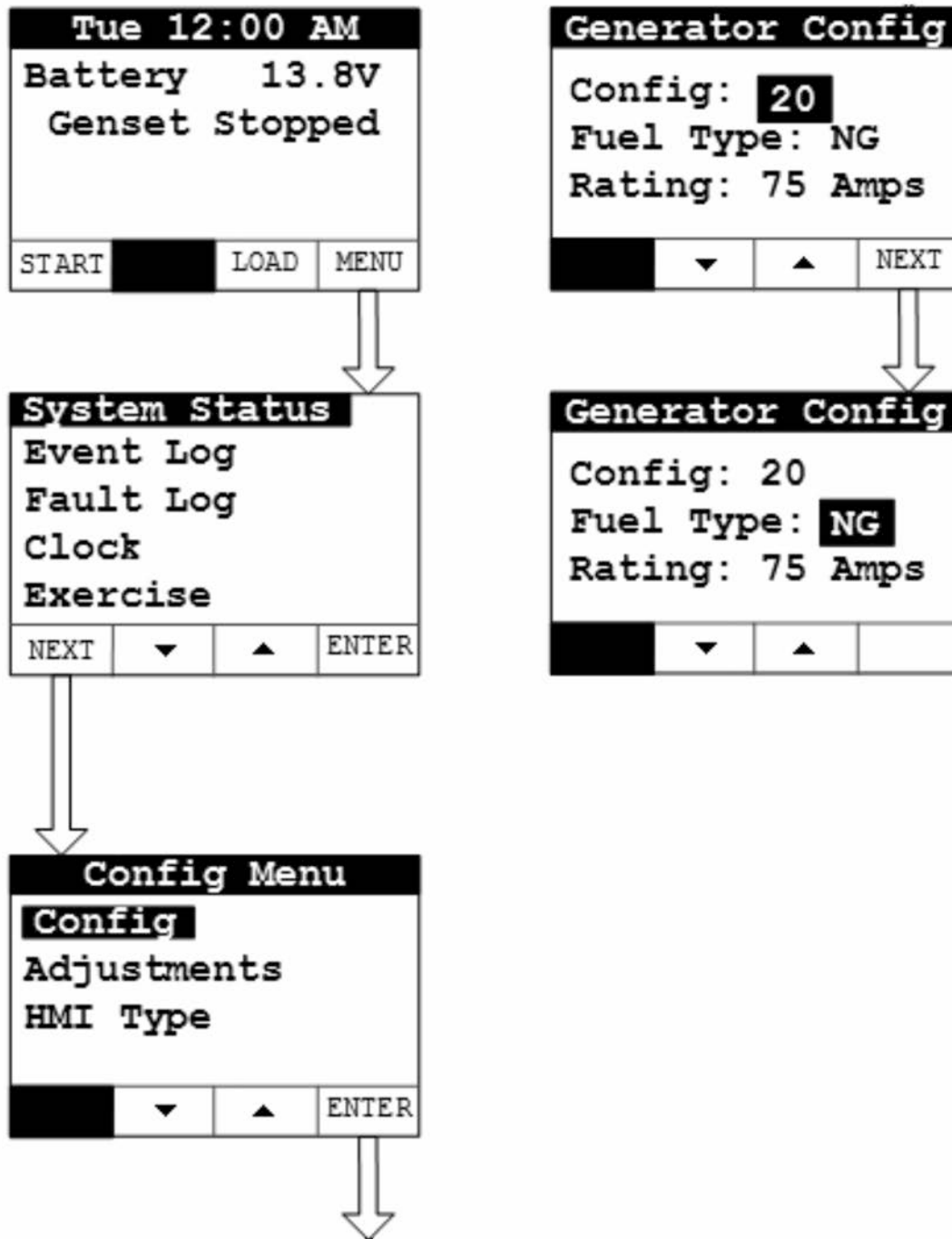
<b>NOTICE</b>
---------------

<b>Do not change the number in the Config field.</b>
------------------------------------------------------

<b>NOTICE</b>
---------------

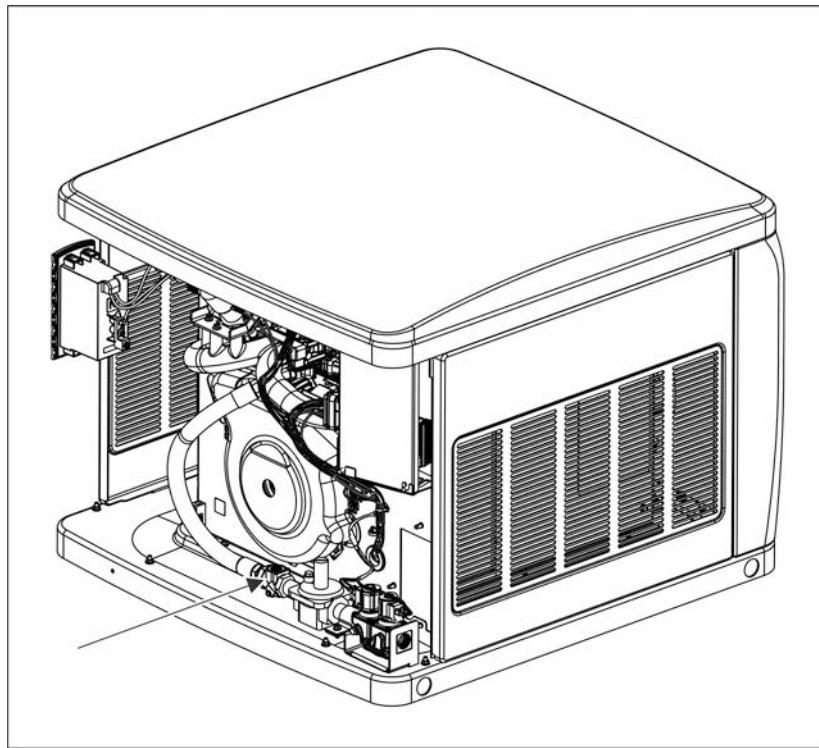
<b>The Rating field is not configurable by the user. Instead, it will be automatically populated based on the Config and Fuel Type field selections.</b>
----------------------------------------------------------------------------------------------------------------------------------------------------------

- 
- 
- 
- 
- e. Keep selecting the **Back** button to save the settings and return to the Main screen.

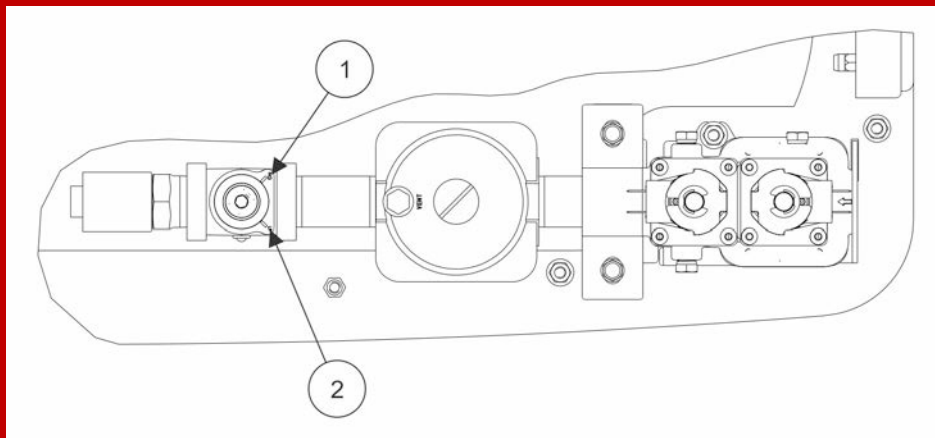


**FIGURE 43. GENERATOR CONFIG SCREEN**

2. Adjust the manual fuel selector to the LP setting:
  - a. Use a 6 mm external hex wrench to rotate the center section of the fuel valve.
  - b. Turn the center section clockwise until the detent is reached.
  - c. When you reach the detent, the required force to turn the valve will increase significantly - do not rotate center section of valve beyond this point.



**FIGURE 44. LOCATION OF FUEL SELECTOR VALVE**



No.	Description	No.	Description
1	Natural Gas Fuel Position	2	Liquid Propane Vapor Fuel Position

**FIGURE 45. MANUAL FUEL SELECTOR**

### Fuel Shutoff Solenoid Troubleshooting

If the generator set does not start, first determine if both valves are in good condition before adjusting the fuel system.

1. Disconnect the four harness leads from the fuel solenoid coils.



2. Check that battery voltage is being supplied through the generator set harness, using a multi-meter to measure DC voltage between:
  - A pair of leads removed from one coil (FSOL1+ and FSGND1)
  - A pair of leads removed from the remaining coil (FSSOL2+ and FSGND2) while trying to start the generator set

**NOTICE**

**There must be sufficient battery power available to engage the starter and rotate the engine).**

Verify that the voltage is 10.2 VDC:

- If no voltage is measured, check for bad wiring.
  - If the voltage is less than 10.2 VDC, check for bad wiring or a discharged battery.
  - If the voltage is greater than 10.2 VDC, check for proper solenoid operation.
3. Check for proper solenoid operation.
    - a. While holding onto the solenoid, apply 12 VDC to a coil on one of the solenoids.
    - b. Listen and feel for the solenoid to activate.
    - c. Repeat applying the voltage a few times to be sure the solenoid operates.
    - d. Repeat these steps for all solenoids.
    - e. If either solenoid does not activate, replace the gas valve assembly.
  4. Check for fuel leaks at the solenoid. With a soapy water solution, check pipe threads and areas around the base of the solenoid for gas leakage.
    - If a pipe thread is showing bubbles, tighten the pipe connection.
    - If anywhere on the gas valve shows bubbles or leakage, replace the complete gas valve assembly.

## Air-Fuel Mixer

1. When reinstalling the air-fuel mixer, make sure to assemble the components in the appropriate order, with three new flange gaskets.
2. Torque the flange bolts to 13 ft-lb (17.5 Nm).

## Governor Actuator Removal and Installation

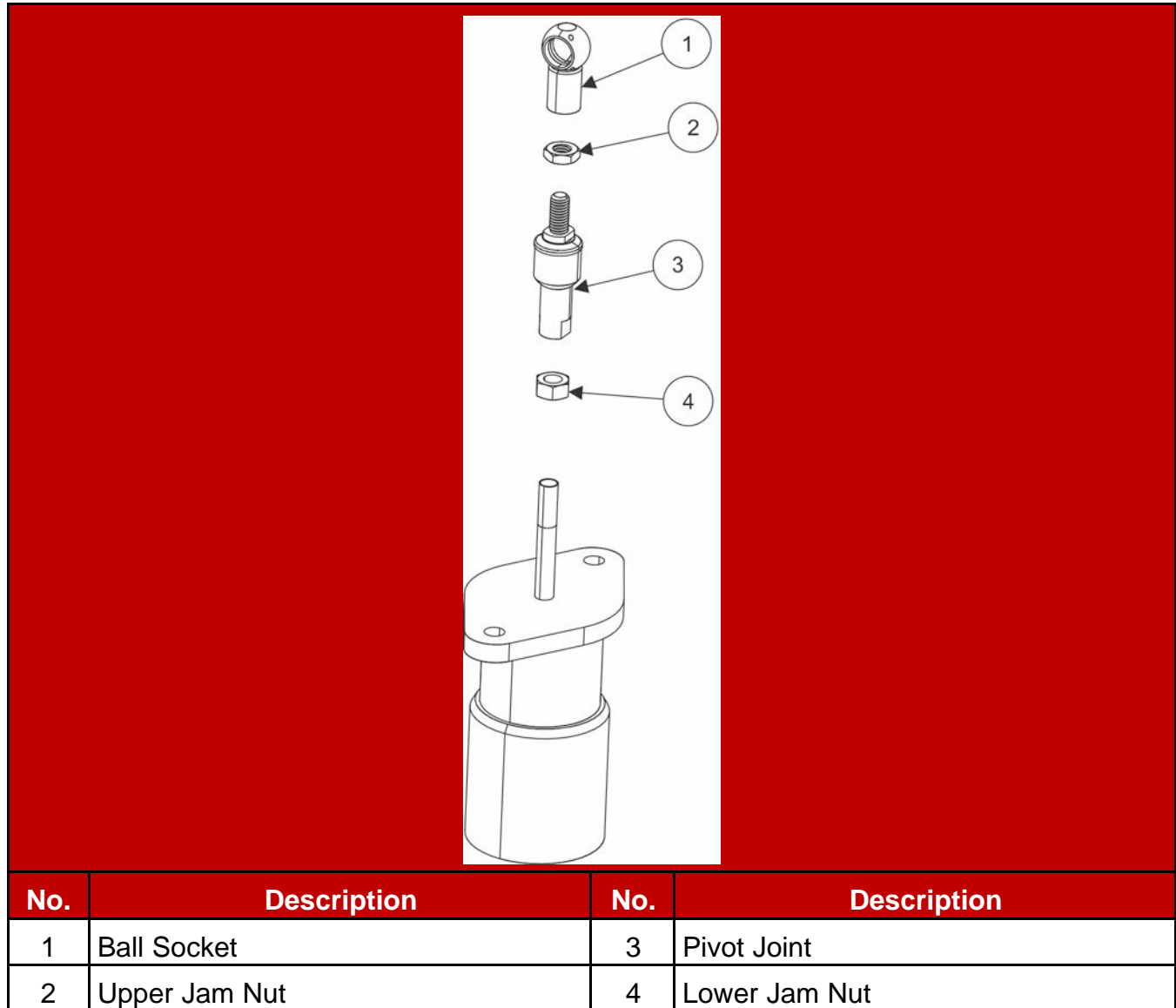
### GOVERNOR ACTUATOR REMOVAL

1. Shut off AC power to the generator set accessories.
2. Open the generator set breaker.
3. Before disconnecting the generator set battery, note the exercise schedule settings.

4. Disconnect the generator set battery, negative post first, then positive post.
5. Open the hood and make sure the hood latch drops into place.
6. Disconnect the battery charger and display electrical plugs.
7. Remove the control access panel. See the figure in the Control Components section.
8. Disconnect the electrical leads.
9. Remove and retain the clip that holds the socket on the ball.
10. Remove the 2 mounting bolts from the bracket.
11. Remove the governor actuator.

### **GOVERNOR ACTUATOR INSTALLATION**

1. Attach the governor actuator and mounting bolts to the actuator bracket.
2. Assemble the governor linkage with the components bottomed out.
  - a. Loosely install the upper jam nut onto the male threads of the pivot joint.
  - b. Bottom out the ball socket on the male threads of the pivot joint.
  - c. Loosely place the lower jam nut onto the actuator arm.
  - d. Bottom out the pivot joint on the male threads of the actuator arm.
3. Install the governor linkage assembly in the generator set.



**FIGURE 46. GOVERNOR LINKAGE ASSEMBLY**

4. Increase the length of the linkage until the gap between the throttle stop screw and the throttle shaft bracket is 0.25-0.30 mm (0.001 in). Adjust both the ball socket and pivot joint equally.
5. Verify that the mixer arm can be moved (with the linkage installed) to the fully open position.
6. Tighten the jam nuts against the base of the ball socket (1) and the base of the pivot joint (3), as shown in [Figure 46](#).
7. Connect the electrical leads from the wiring harness to the governor actuator.
8. Install the control access panel.
9. Connect the generator set battery and reset the display settings.
10. Turn on AC power to the generator set accessories.

11. Test run the generator set for 5 minutes with no load.
12. Close the generator set breaker.

## 6.3 Cylinder Head Assembly Replacement

### Parts required:

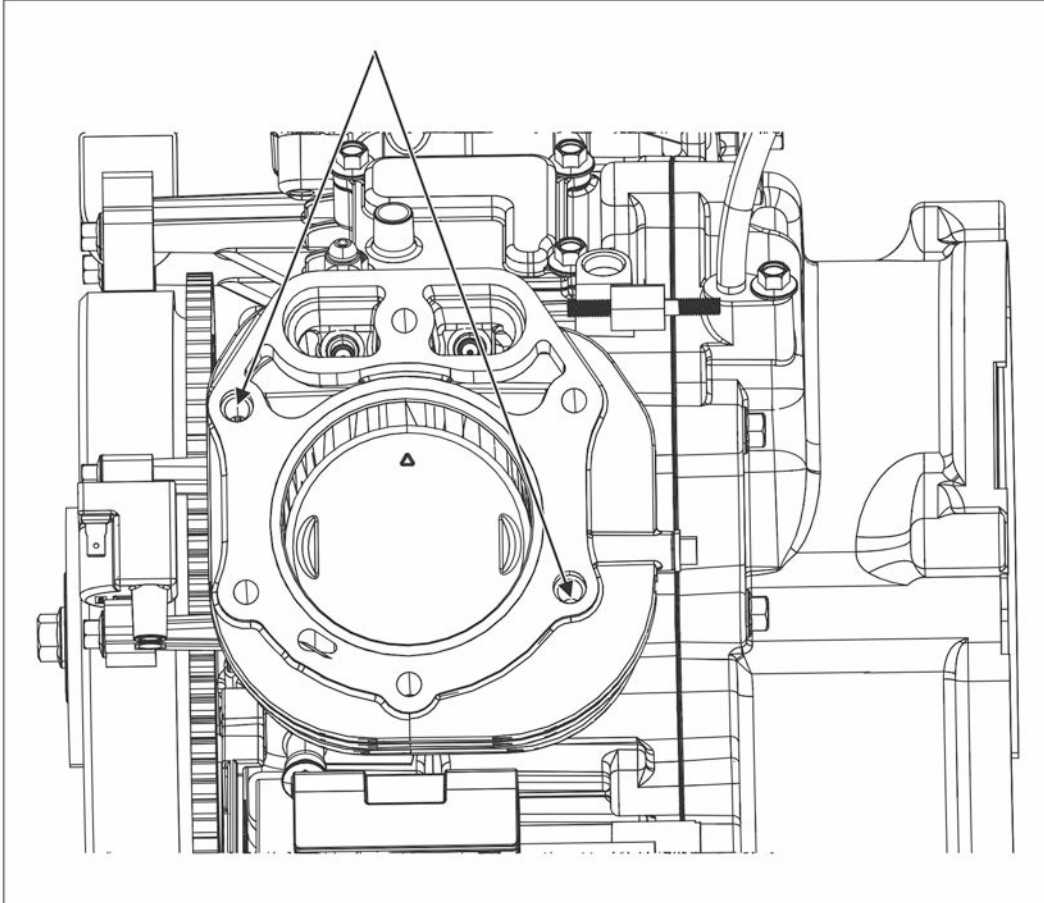
- Cylinder head assembly
- Cylinder head gasket
- Valve cover gasket

### Tools required:

- General mechanical tools

### Procedure:

1. Make sure the generator set is shut down and disabled:
  - a. Press the generator set's red STOP button on the local display to stop the generator set. Allow the generator set to thoroughly cool to the touch.
  - b. Turn off and disconnect the battery charger from the AC source before disconnecting the battery cables.
  - c. Disconnect the negative (–) cable from the battery first and secure it from contacting the battery terminals to prevent accidental starting. Then disconnect the positive cable.
2. Remove the necessary enclosure panels and service access panels (and oil cooler if needed) to access to the cylinder head.
3. Remove the engine shield below the valve cover.
4. Remove the four valve cover mounting bolts, valve cover and valve cover gasket.
5. Remove rocker arms, rotating the engine first to ensure there is no valve spring pressure on the rocker arm you are removing.
6. Remove the six cylinder head bolts and the cylinder head. Make sure to retain the two cylinder locating sleeves from each cylinder head. See the figure below.



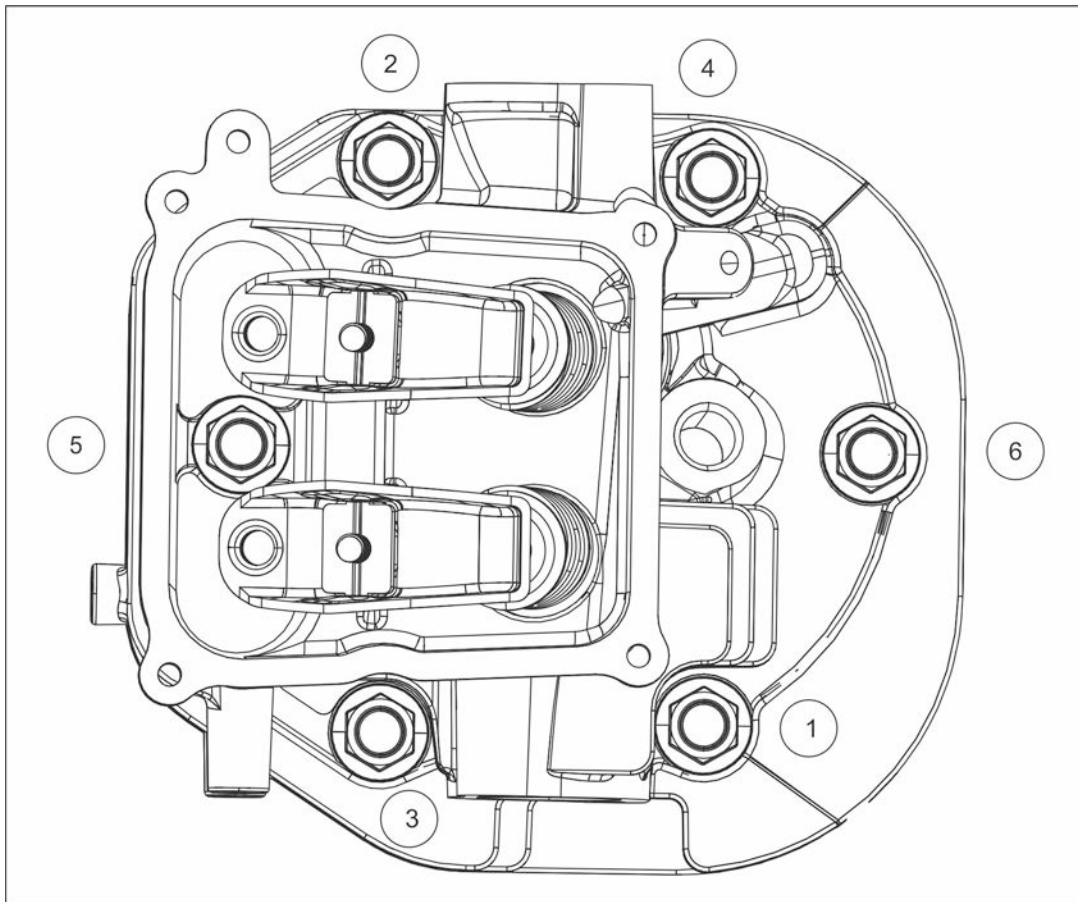
**FIGURE 47. CYLINDER LOCATING SLEEVES**

7. Remove the head gasket. Make sure to safely remove any gasket material left behind on the mating surface of the engine block.

**NOTICE**

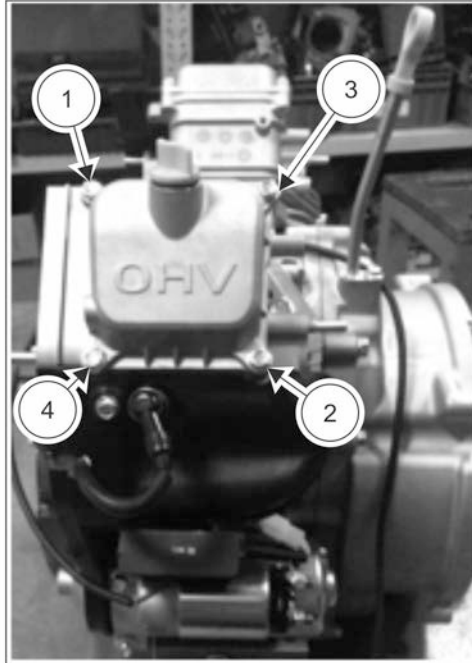
**Any damage done to the mating surface may cause a leak when reassembled.**

8. Install the locating sleeves and the new head gasket. See [Figure 47](#).
9. Install the new cylinder head assembly, tightening the bolts in the pattern shown below to 50 Nm (36.9 ft-lb).



**FIGURE 48. CYLINDER HEAD ASSEMBLY BOLT TORQUE SEQUENCE**

10. Apply Loctite 262 to the stud. Attach the rocker arm and nut to the stud. Tighten the nut to 8 - 12 Nm (71 - 106 lb-in).
11. Adjust the valve clearance (see the Model Specifications section and the Engine Valve Clearance section). Tighten the nuts together to 14 - 18 Nm (10.4 lb-in - 13.3 lb-ft).
12. Assemble new valve cover gasket and valve cover. Tighten the bolts following the sequence below to 8 - 12 Nm (71 - 106 lb-in).



**FIGURE 49. VALVE ADJUSTMENT BOLT TORQUE SEQUENCE**

13. Re-install the panels that were removed in step 2.
14. Re-connect the battery by first connecting the positive terminal first, then the negative terminal.
15. Restore power to the AC accessories and restore the generator set settings.
16. If possible, test run the generator set with load.

## 6.4 Engine Exhaust

The exhaust system for this generator set is complete and was designed specifically for this generator set. Do not modify or add to the exhaust system of this generator set.

**⚠ WARNING**

***Exhaust gas is deadly. Make sure that the exhaust system terminates away from building vents, windows, doors, and sheltered spaces that may not have ample fresh air ventilation.***

**⚠ WARNING**

***Engine discharge air and exhaust carry carbon monoxide gas (odorless and invisible) which can cause asphyxiation and death. Never use engine discharge air or exhaust for heating a room or enclosed space.***

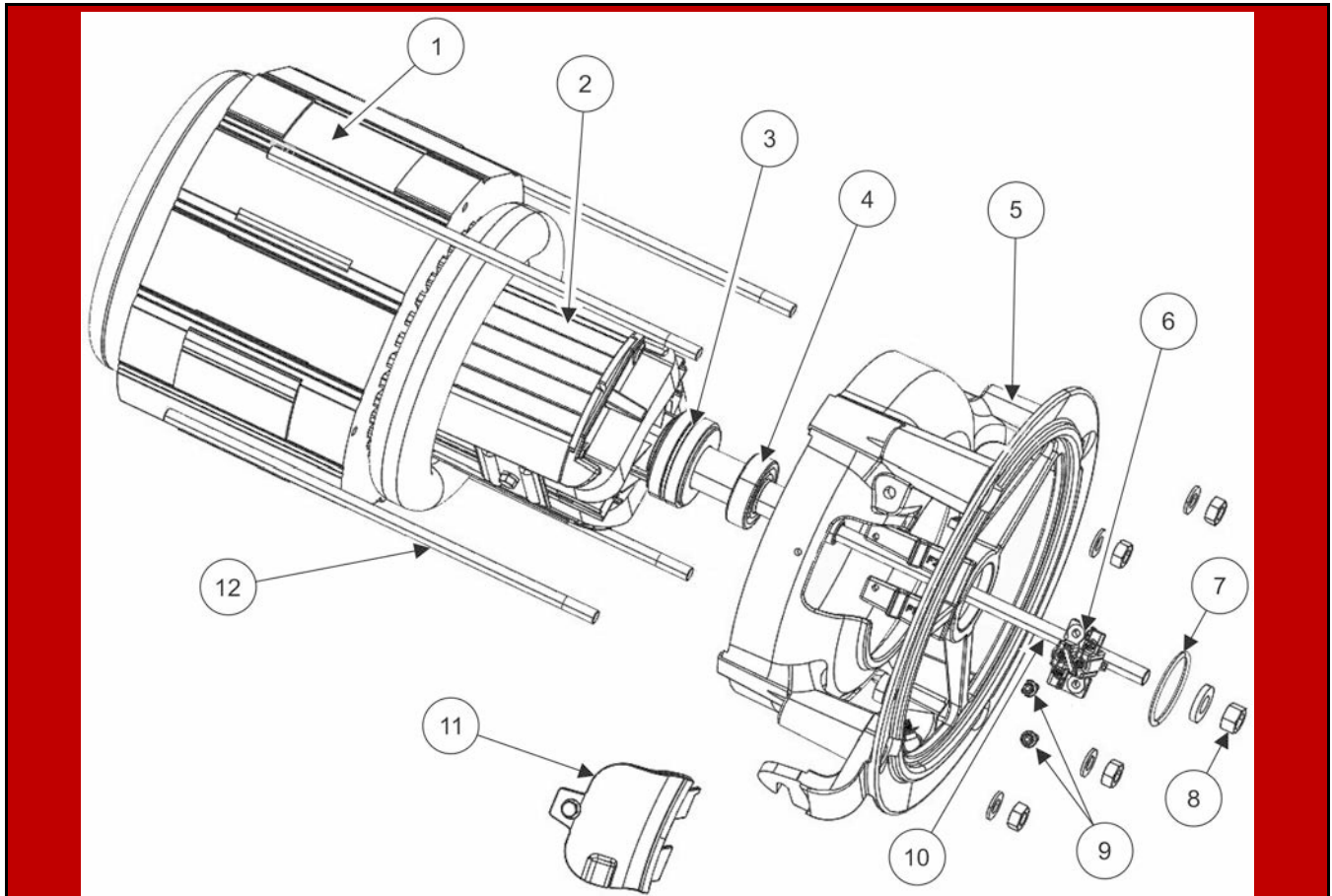
## 6.5 Alternator

### Alternator Components

This is a single-bearing, two-pole, revolving field alternator with brushes and slip rings. Output voltage is regulated by the generator set control. Here are the major components:

Component	Description
Stator	The stator consists of steel laminations with two sets of windings in the lamination slots. The main windings (L1-L2, Neutral) power the connected loads and the quadrature windings (Q1-Q2) supply power for the alternator field. See the Testing the Alternator section.
Rotor	The rotor consists of a shaft with steel laminations wrapped with windings. A molded slip ring assembly supplies field current to the rotor windings through the brush block assembly. The rotor shaft is supported in the end bell by a sealed ball bearing. The rotor is driven by the taper on the end of the engine crankshaft.
Brush Block	Field current passes through the brush block which has two spring-loaded carbon brushes that make contact with the rotor slip rings.
Voltage Regulator	The generator set control maintains constant output voltage under varying load conditions by varying field current. Power for field excitation is supplied by the quadrature winding (Q1-Q2).





No.	Description	No.	Description
1	Stator	7	O-Ring
2	Rotor	8	Rotor Mounting Washer and Nut
3	Commutator Ring Assembly	9	Brush Block Mounting Screws
4	Bearing	10	Threaded Rod (Rotor Mounting Stud)
5	End Bell (Bracket)	11	Access Cover
6	Brush Block Assembly	12	Threaded Rod (Mounting Stud)

**FIGURE 50. ALTERNATOR**

## Alternator Heater

**⚠ DANGER**

***Live Electrical Conductors***

***Live electrical conductors can cause serious injury or death by electric shock and burns.***

***To prevent injury and before removing covers over electrical conductors, isolate the generator set from all energy sources, remove stored energy and use lock out/tag out safety procedures.***

Power to the alternator heater is supplied from a separate source. The alternator heater raises the air temperature around the windings to deter condensation forming in humid conditions when the generator set is not operating.

## Alternator Temperature Switch

The alternator temperature switch helps protect the generator set when unusual conditions occur such as severe blockage of the air intake or air discharge panels. The temperature switch is fastened to the lower stator through-bolt on the non-drive end of the alternator and on the exhaust side of the enclosure near the brush block maintenance panel. The temperature switch contacts are normally closed. The switch contacts open at 197 – 210 °F (92 – 99 °C). If the switch contacts open, the generator set control will turn off the generator set.

## Sealed Bearings

Inspect sealed-for-life bearings periodically. Check for signs of wear, fretting or other detrimental features. Damage to seals, grease leakage or discoloration of the bearing races indicate that the bearing may need to be replaced.

## Brush Block/Slip Ring Service

1. Disconnect the field leads from the brush block (F1, F2).
2. Remove the two mounting screws.
3. Withdraw the brush block from the alternator end bell.
4. Inspect the brush block:
  - a. If either brush is shorter than 11 mm (7/16 inch), binds in the brush block, or is damaged in any way, replace the brush block assembly.
    - i. When installing the brush block, make sure to keep the brushes in the retracted position by using a wire through the hole in the end of the brush block. A new brush block assembly will come with this wire in place.
    - ii. After bolting the brush block securely in place, remove the wire.

**NOTICE**

**Make sure that the brushes are aligned correctly with the slip rings; otherwise, the brushes may break when the generator set is started.**

- b. If the slip rings have grooves, pits, or other damage, use a Scotch Brite pad or commutator stone to remove light wear or corrosion.

## Testing the Alternator

### 1. Rotor Winding Continuity:

- Test the rotor for grounded, open and shorted windings using an ohmmeter, testing at the brush block terminals first.
- If the resistance is high, remove the brush block and test directly on the slip rings.
- Replace the brush block if a high resistance is due to the brushes.

### 2. Rotor Ground Resistance Test:

- Set the ohmmeter to the highest resistance scale, or use a megger.
- Touch one test probe to the rotor shaft and the other to one of the slip rings.
- Refer to the table below for resistance values. If test values do not match measurement values, replace the alternator.

**TABLE 13. ROTOR AND STATOR RESISTANCE TESTS**

Tests	Measurement Values
Rotor Ground Resistance	Reading > 1 megohm (one million Ohms) on megger, or infinity on an ohmmeter
Rotor Winding Resistance F1 to F2 (at 75° F - room temperature)	<ul style="list-style-type: none"> <li>• 13 kW = 26 +/-10% Ohms</li> <li>• 17/20 kW = 30.5 +/-10% Ohms</li> </ul>
Main Winding to Quad Winding	Open (infinity) for any winding
Stator Ground Resistance	Reading > 1 megohm (one million Ohms) on megger, or infinity on an ohmmeter.
Stator Winding Resistance (at 75° F - room temperature):	
L1 to N	<ul style="list-style-type: none"> <li>• 13 kW = 0.112 +/-10% Ohms</li> <li>• 17/20 kW = 0.042 +/- 10% Ohms</li> </ul>
L2 to N	<ul style="list-style-type: none"> <li>• 13 kW = 0.112 +/-10% Ohms</li> <li>• 17/20 kW = 0.042 +/- 10% Ohms</li> </ul>

Tests	Measurement Values
L1 to L2	Value should be equal to sum of L1 to N and L2 to N measurements above $\pm 1\%$ Ohms
Q1 to Q2	<ul style="list-style-type: none"> <li>• 13 kW = 2.56 +/- 10% Ohms</li> <li>• 17/20 kW = 1.45 +/- 10% Ohms</li> </ul>
L1 to Q1	Infinity
L1 to Gnd	Infinity
L2 to Gnd	Infinity
Sense L1(W) - Sense L2(V)	<ul style="list-style-type: none"> <li>• 13 kW = 0.24 +/-10% Ohms</li> <li>• 17/20 kW = 0.107 +/- 10% Ohms</li> </ul>
Q1 to Laminations	Infinity
*If a stator or rotor fails the initial test, repeat the test to check the validity of the initial measurement before replacing the stator or the rotor.	

3. *Rotor Winding Resistance:*

- a. Connect each meter test lead to a separate slip ring.
- b. Refer to [Table 13](#) for resistance values. If test values do not match measurement values, replace the alternator.

4. *Main Winding to Quad Winding:* Test for a short between the main windings and the quad windings.

5. *Stator Ground Resistance Test:*

- a. Set the ohmmeter to the highest resistance scale, or use a megger.
- b. Touch one test probe to the stack and, in turn, the other to each stator lead. Refer to [Table 13](#) for measurement values.

6. *Stator Winding Resistance:* Use a meter (Wheatstone bridge) having a precision down to 0.001 Ohms to measure stator winding resistance values as shown in [Table 13](#).

7. *Stator Winding for Grounds:* With an ohmmeter, measure each winding to the stator laminations to check for bad insulation. Refer to [Table 13](#) for measurement values.

**NOTICE**

**This alternator is rated in accordance with UL 2200 (Stationary Engine Generator Assemblies) or CSA C22.2 No. 100-04 (Motors and Generators).**

8. *Verify Generator Set Performance:*

For these products, generator set output power is equal to amperage multiplied by line to line voltage; that is, power (Watts) = amperage x voltage (L-L). The C17N6H generator set model is rated at 70.8 Amps, at 240 V Line to Line, which is equal to a power of 17,000 Watts (70.8 A x 240 V). If the generator set is operating at its rated elevation and temperature, and the voltage is reduced from 240 to 230 volts, the amperage will increase from 70.8 to 73.9 if the load on the generator set is identical. To verify generator set power output:

Using the equation  $power = amperage \times voltage$  can help determine if the generator set is functioning properly, or is not providing the expected power. Using the voltage measured at the generator set mounted circuit breaker, and the current through the load leads, you can calculate the power produced by the generator set and compare that to what is expected to be available. It may be difficult to determine the exact power output of the generator set using the customer's connected load, because these loads are seldom always on (heating and cooling loads typically cycle on and off, and have a high initial starting power requirement). If required, a load bank can be used to determine the full output power of the generator set. See the Model Specifications for derate information.

### Generator Set Derating Guidelines

Maximum wattage or maximum current are subject to and limited by such factors as fuel BTU content, ambient temperature, elevation, engine power, etc. The starting point for derate caused by elevation or temperature varies depending on the generator set model. Full rated power is available at 60 °F (15.5 °C) at sea level. See the Model Specifications section for generator set derating guidelines for all models. The table below is an example of applying product derates for warmer temperature and higher elevation.

**TABLE 14. DERATE CALCULATION EXAMPLE\***

Factor	Values		
<b>Scenario</b>	A C17N6H model generator set is located at 2750 ft above sea level and the air temperature is 93 °F.		
<b>Generator Set Rating</b>	70.8 Amps x 240 Volts = 17,000 Watts		
<b>Elevation Derate Schedule*</b>	3.5% per each 1000 ft over 1000 ft		
<b>Temperature Derate Schedule</b>	3% per each 10 °F above 77 °F		
<b>Calculation</b>	<b>Equation</b>	<b>Example Calculation</b>	<b>Example Result</b>

Factor	Values		
<b>Derate for Elevation</b>	<i>Operating Elevation - Rated Elevation = Total ft Above Rated</i>	2750 ft - 1000 ft =	1750 ft
	<i>Total ft Above Rated/1000 ft = Elevation Ratio</i>	1750/1000 =	1.75
	<i>Elevation Ratio x Derate Schedule = % Reduction of output from Elevation (Elevation Reduction)</i>	1.75 x 3.5% =	6.1%
<b>Derate for Temperature</b>	<i>Operating Temperature - Rated Temperature = Total °F Above Rated</i>	93 °F - 77 °F =	16 °F
	<i>Total °F Above Rated/10 °F = Temperature Ratio</i>	16/10 =	1.6
	<i>Temperature Ratio x Derate Schedule = % Reduction of Output from Temperature (Temperature Reduction)</i>	1.6 x 3% =	4.8%
<b>Total Derate</b>	<i>Elevation Reduction + Temperature Reduction = Total Reduction</i>	6.1% + 4.8% =	10.9%
	<i>Total Reduction/100 = Decimal Percent Reduction</i>	10.9/100 =	0.109
	<i>Total Watts x Decimal Percent Reduction = Expected Power Reduction</i>	17,000 x 0.109 =	1,853 Watts
	<i>Total Watts - Expected Power Reduction = Expected Power</i>	17,000 - 1,853 =	15,147 Watts
	<i>Total Amps x Decimal Percent Reduction = Expected Current Reduction</i>	70.8 x 0.109 =	7.7 Amps
	<i>Total Amps - Expected Current Reduction = Expected Current</i>	70.8 - 7.7 =	63.1 Amps
* This schedule is for the C17N6H model only. See the Model Specifications section for generator set derating guidelines for all models.			

## Parts Identification

### Single Bearing Alternator

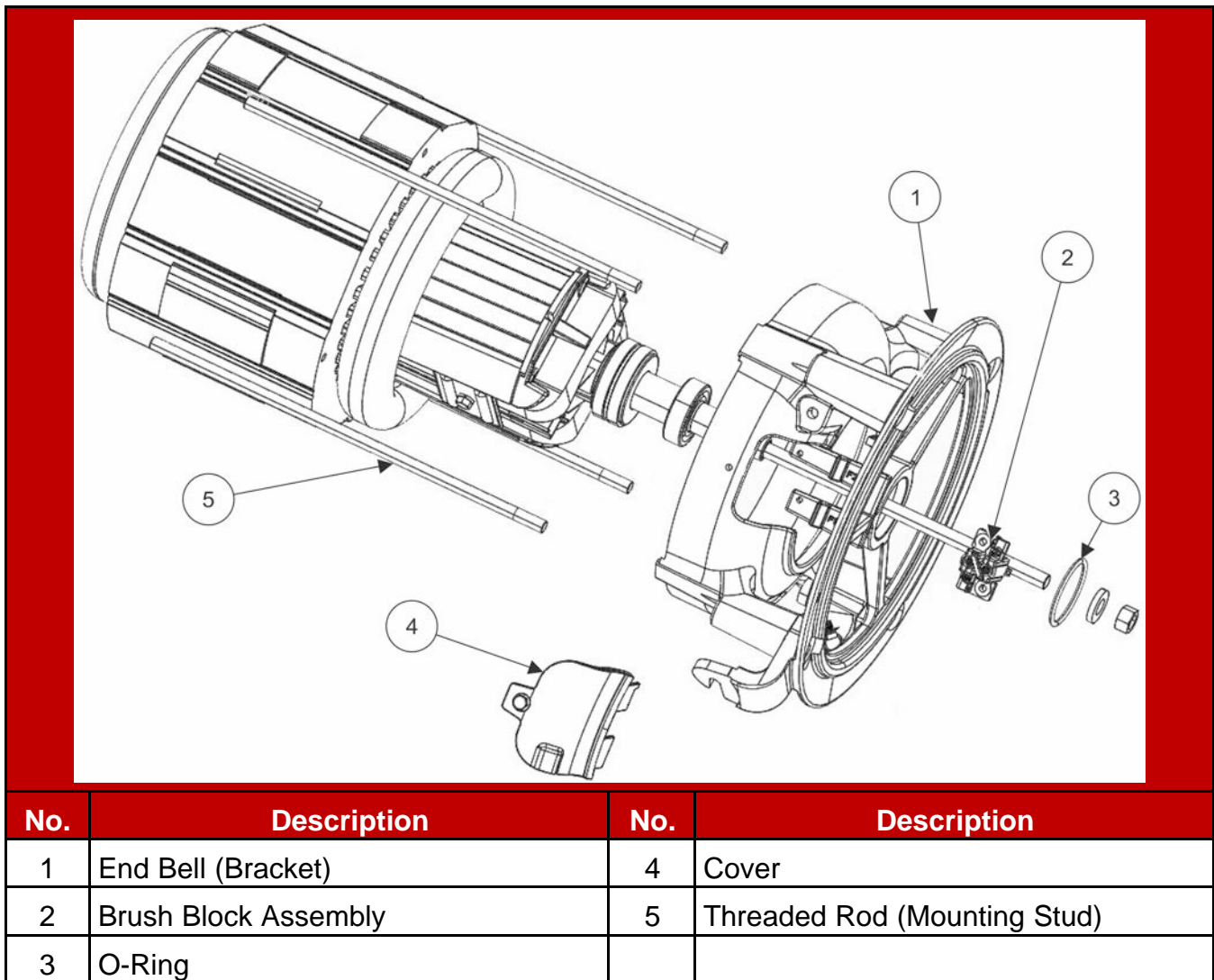


FIGURE 51. ALTERNATOR PARTS

## Windings

### Introduction

#### NOTICE

Disconnect all control wiring and customer load leads from alternator winding connections before conducting these tests.



**NOTICE**

**The Automatic Voltage Regulator (AVR) contains electronic components which would be damaged by high voltage applied during insulation resistance tests. The AVR must be disconnected before doing any insulation resistance test. Temperature sensors must be grounded to earth before doing any insulation resistance test. Damp or dirty windings have a lower electrical resistance and could be damaged by insulation resistance tests at high voltage. If in doubt, test the resistance at low voltage (500 V) first.**

Alternator performance depends on good electrical insulation of the windings. Electrical, mechanical and thermal stresses, and chemical and environmental contamination, cause the insulation to degrade. Various diagnostic tests indicate the condition of insulation by charging or discharging a test voltage on isolated windings, measuring current flow, and calculating the electrical resistance by Ohm's law.

When a DC test voltage is first applied, three currents can flow:

- **Capacitive Current:** To charge the winding to the test voltage (decays to zero in seconds),
- **Polarizing Current:** To align the insulation molecules to the applied electric field (decays to near-zero in ten minutes), and
- **Leakage Current:** Discharge to earth where the insulation resistance is lowered by moisture and contamination (increases to a constant in seconds).

For an insulation resistance test, a single measurement is made one minute after a DC test voltage is applied, when capacitive current has ended. For the polarization index test, a second measurement is made after ten minutes. An acceptable result is where the second insulation resistance measurement is at least double the first, because the polarization current has decayed. In poor insulation, where leakage current dominates, the two values are similar. A dedicated Insulation Tester takes accurate, reliable measurements and may automate some tests.

**Safety**** DANGER*****Live Electrical Conductors***

***Live electrical conductors can cause serious injury or death by electric shock and burns.***

***To prevent injury and before removing covers over electrical conductors, isolate the generator set from all energy sources, remove stored energy and use lock out/tag out safety procedures.***



**⚠ WARNING*****Live Electrical Conductors***

***Live electrical conductors at the winding terminals after an insulation resistance test can cause serious injury or death by electric shock or burns.***

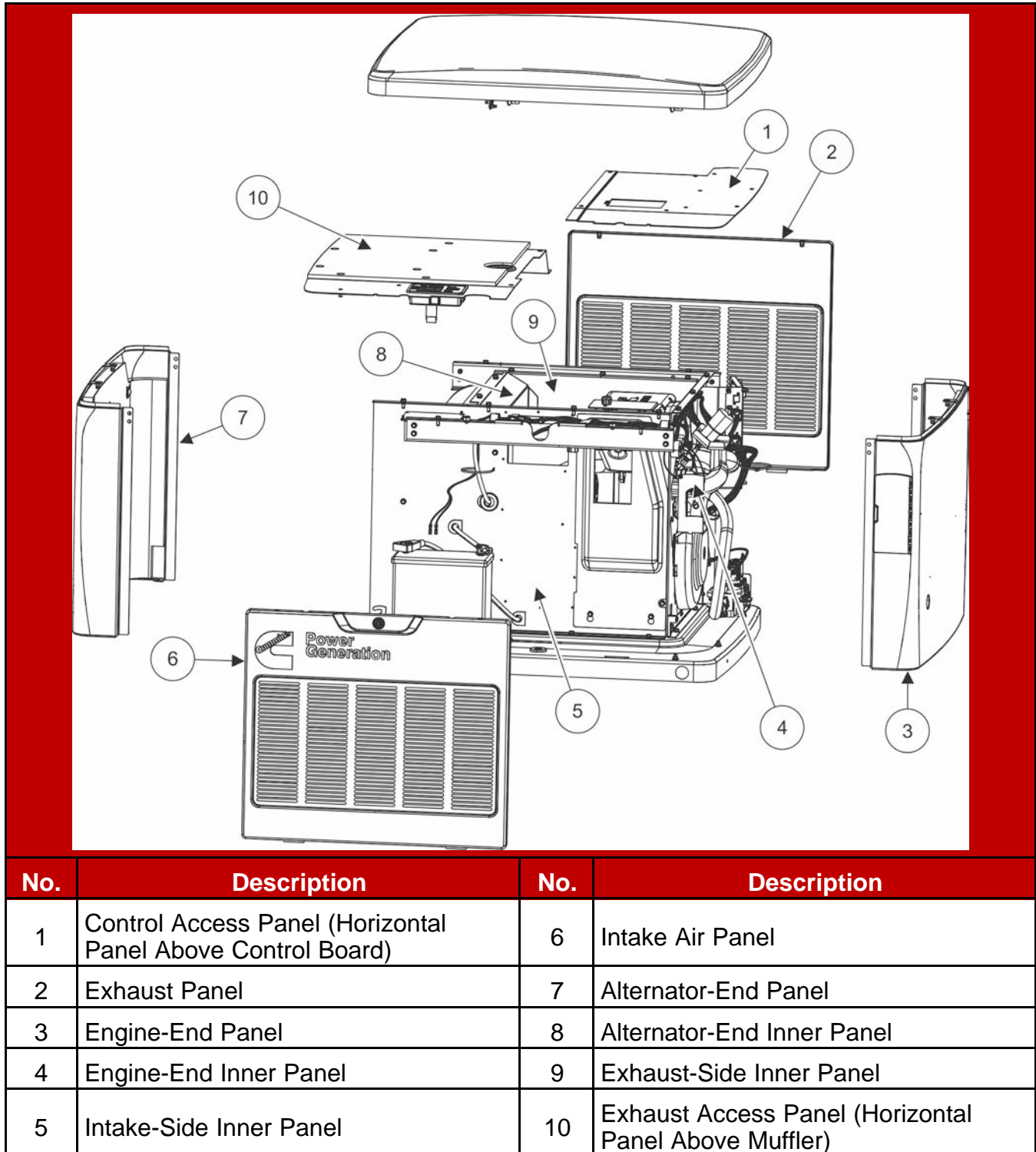
***To prevent injury, discharge the windings by shorting to earth through an earthing rod for at least 5 minutes.***

**Requirements****TABLE 15. WINDING TEST REQUIREMENTS**

<b>Type</b>	<b>Description</b>
Personal Protective Equipment (PPE)	Wear mandatory site PPE.
Consumables	None
Parts	None
Tools	Insulation test meter
	Multimeter
	Milliohm meter or microohm meter
	Clamp ammeter
	Infrared thermometer
	Earth rod

**Alternator and Engine Removal and Installation****ALTERNATOR AND ENGINE REMOVAL**

1. Obtain the tools and parts required. See the Tools and Parts Required section.
2. Disconnect the AC utility source.
3. Open the hood.
4. Remove the intake air and exhaust panels. See the "Removal of Panels" image in the Engine Valve Clearance section.



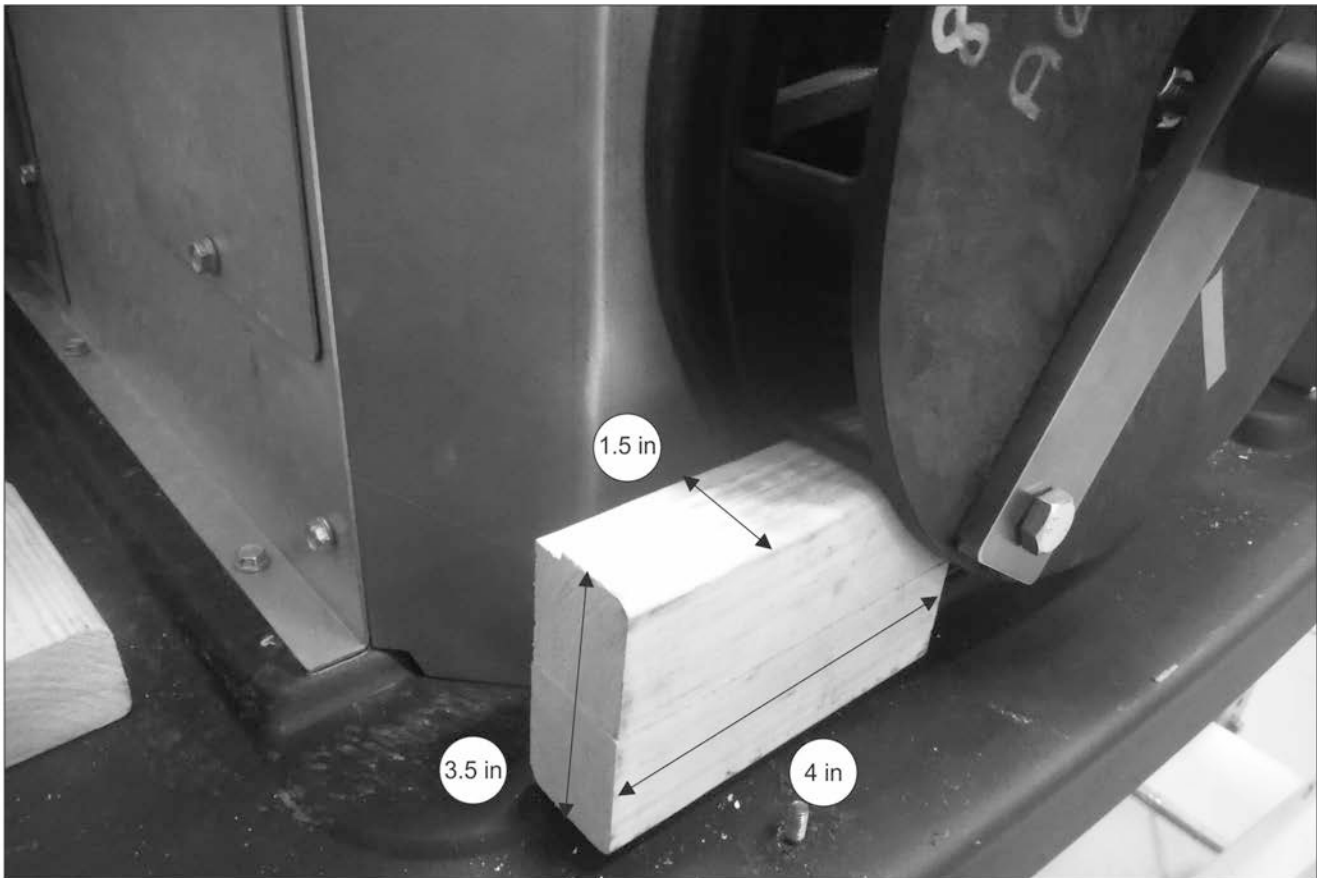
**FIGURE 52. REMOVAL OF PANELS**

5. Remove the negative battery cable first, then remove the positive battery cable.

6. Remove the battery.

7. Disconnect the HMI (P1 on the display) and AC battery charger (BC-P).

8. Remove the control access and exhaust access panels.
9. Remove the alternator-end panel, hood, and cross braces. Leave the engine-end panel in place so there is no need to disconnect the fuel and electrical systems.
10. Remove the alternator fan as follows:
  - a. Cut a piece of standard 2x4 (1.5 in x 3.5 in) to 4 inches long.
  - b. Block the alternator fan from turning as shown below.



**FIGURE 53. BLOCKING THE ALTERNATOR FOR REMOVAL**

- c. Loosen the rotor retaining nut.
  - d. Double nut the rotor through-stud by adding an M12 x 1.75 nut to the loosened rotor nut.
  - e. Unthread the rotor through-stud, and remove it along with the washer and nuts.
  - f. Attach a bar-type gear/wheel puller with M6 bolts and 1¼ in width capacity.
  - g. Use a socket or similar tool less than 18.6 mm (0.73 in) in diameter between the wheel/gear puller and the rotor to pull the fan off the rotor.
11. Remove the exhaust muffler.
  12. Remove the exhaust-end inner panel.

- 
13. Disconnect the battery charger wiring harness from the intake-side inner panel.
  14. Disconnect the alternator leads from the circuit breaker. Note the orientation of the current transformers (CTs). The stator leads must pass through the CTs in the same direction during reassembly.
  15. Remove the oil filter access panel.
  16. Remove the oil cooler mounting bolts.
  17. Remove the intake-side inner panel.
  18. Remove the alternator-end inner panel.
  19. Remove the inner panel below the exhaust muffler.
  20. Remove the stator as follows:
    - a. Remove the brush block (see the Brush Block/Slip Ring Service section).
    - b. Disconnect the 2 alternator heater wiring leads if connected.
    - c. Support the bottom of the stator so that it does not contact the rotor.
    - d. Remove the isolator mount nuts and isolator mounts.
    - e. Remove the nuts and washers on the 4 stator through-studs.
    - f. Remove the end bell, o-ring and rotor bearing.
    - g. Pull the stator straight out and away from the engine, leaving the rotor and stator through-studs in place. Be sure to avoid contact with the rotor or stator windings.
  21. Remove the rotor as follows:
    - a. Remove the stator and through-studs.
    - b. Remove the nut and flat washer on the rotor through-stud.
    - c. Use the 2 nuts locked together at the end of the rotor through-stud to loosen and remove the through-stud from the crankshaft.
    - d. Thread in a rotor removal tool (see the Rotor Removal Tool section).
    - e. Using the groove in the end of the rotor removal rod, turn the rod with a screwdriver until it bottoms in the crankshaft.
    - f. Thread in and tighten an M14 x 2.0 bolt against the rod until the rotor breaks loose from the crankshaft.
    - g. Remove the rotor removal tool.
    - h. Remove the rotor.
  22. Remove the engine as follows:
    - a. Drain the engine oil. See the Engine Oil and Oil Filter Change section.
    - b. Remove the governor actuator linkage.
    - c. Remove the fuel line from the mixer assembly.
    - d. Remove the airbox top and air filter.
    - e. Remove the 4 mixer mounting nuts.
-

- f. Find the grommet connecting the crank-case reed valve assembly to the airbox. Remove the grommet carefully along with the airbox.
- g. Remove the intake manifold nuts mounting the manifold to the engine.
- h. Remove the intake manifold and mixer.
- i. Remove the remaining wiring harness connections from the oil level sensor, oil pressure sensor, and oil plug heater (if present).
- j. Remove the exhaust manifold.
- k. Remove the isolator mount nuts and isolators.
- l. Remove the engine.

### **ALTERNATOR AND ENGINE INSTALLATION**

1. Install the dipstick shipped with the engine. Place a bead of Loctite 518 (or equivalent high temperature thread sealant) on the dipstick threads.
2. Reposition the engine.
3. Install the engine isolator bolts. Torque to 24-29 Nm (17.7-24.1 lb-ft).
4. Install the alternator rotor:
  - a. For a complete rotor and stator assembly (that is, a complete alternator), both installed at the same time:
    - i. Remove any shipping brackets and position the alternator for installation. Do not allow contact between the rotor and stator windings.
    - ii. Slide the rotor onto the engine output shaft.
    - iii. Align the stator through-bolts with the engine mounting hole, and thread them into the holes. Torque the stator through-bolts by hand.
    - iv. Insert the rotor through-bolt and thread it into the engine taper by hand until the bolt bottoms out.
  - b. For a rotor-only installation:
    - i. Slide the rotor onto the engine taper.
    - ii. Insert the rotor through-bolt and thread it into the engine taper by hand until it bottoms out.
  - c. For a stator-only installation:
    - i. Slide the stator/endbell over the rotor and align the stator through-bolts to the engine holes to properly seat the rotor bearing. Do not allow contact between the stator and the rotor.
    - ii. Thread the stator through-bolts in to the engine and hand-tighten.
5. Install the alternator isolator bolts. Torque the bolts to 24 - 29 Nm (17.7 - 24.1 lb-ft).
6. Check the engine oil level. Add or drain oil as needed. Refer to the Model Specifications section for the appropriate oil grade and weight.

- 
7. Install the intake manifold with new gaskets (see the parts manual). Torque the nuts to 11 - 14 Nm (97 - 124 lb-in).
  8. Install the governor actuator linkage onto the throttle shaft. See the Governor Actuator Removal and Installation section.
  9. Install the exhaust manifold and mixer assembly using new gaskets (see the parts manual). Torque the nuts to 33 - 40 Nm (24.3 - 29.5 lb-ft).
  10. Install the airbox and air filter. Torque the mounting bolts and mixer nuts to 3.2 - 4.0 Nm (28 - 35 lb-in).
  11. Make sure the grommet between the airbox and the crankcase reed valve assembly is seated correctly.
  12. Install the electrical connections to the alternator heater, oil level switch, and oil plug heater (if present).
  13. Route the wiring connector for the oil pressure switch underneath the engine/alternator connection, and then reconnect it to the sensor.
  14. Attach the alternator temperature switch to the lower stator bolt with a zip tie.
  15. Thread the battery cables and the alternator leads through the grommets in the intake-side inner panel as follows:
    - Positive cable through the lower hole
    - Negative cable and alternator leads through the upper hole
  16. Attach the following to the starter in the order shown:
    - a. Positive cable
    - b. DC voltage regulator lead
    - c. Control wire terminalsTorque the nut to 8 - 10 Nm (71 - 89 lb-in).
  17. Thread the positive battery cable through the lower grommeted hole.
  18. Install the endbell.
  19. Attach the following to the endbell in the order shown:
    - a. Negative battery cable
    - b. Engine ground 1 wire
    - c. Engine ground 2 wire
    - d. Engine ground 3 wire
    - e. Alternator ground strapTorque the bolt to 12.3 - 15 Nm (109 - 133 lb-in).
  20. Connect the positive cable to the starter. Torque the nut to 25 - 30 Nm (18.4 - 22.1 lb-ft).
  21. Install the remaining alternator ground strap bolt with the following parts on the skid in the following order:
    - a. Star washer
-

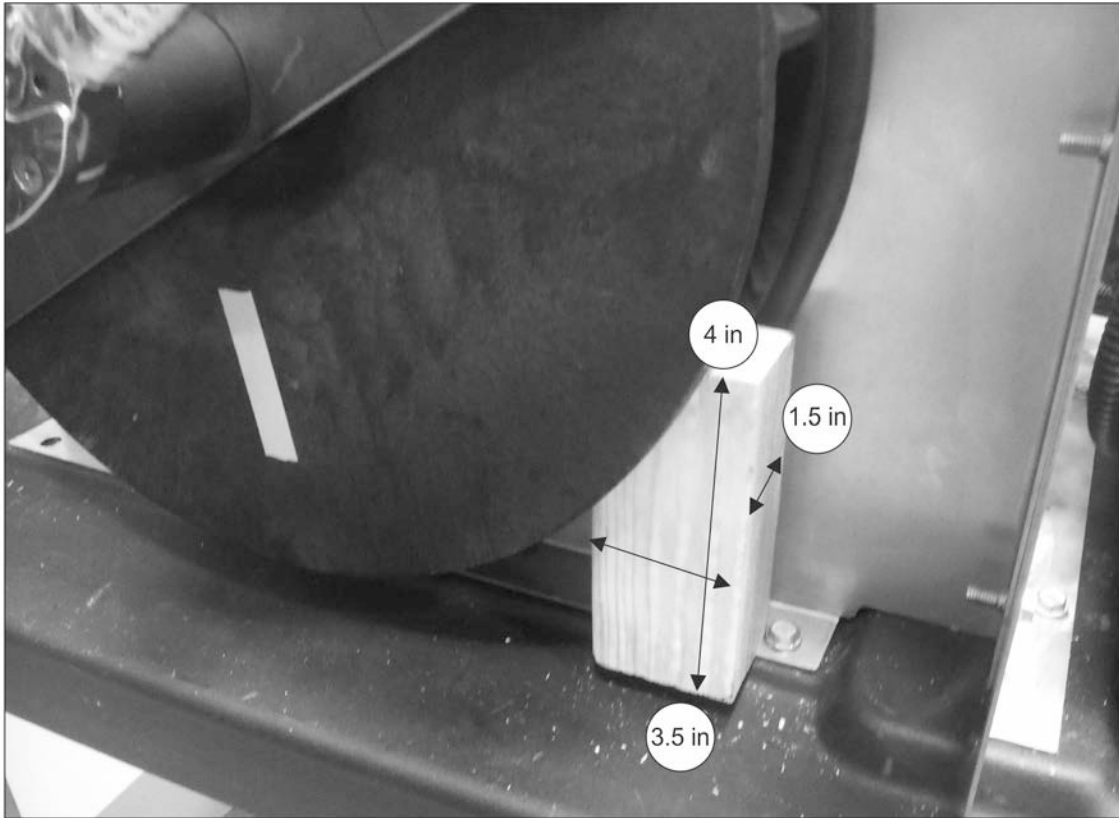
- b. Flat washer
- c. Alternator ground strap
- d. Flat washer
- e. Bolt

Torque the bolt to 5 - 6.2 Nm (44 - 55 lb-in).

22. Connect the alternator leads to the circuit breaker. Torque the leads 4 - 5 Nm (35 - 44 lb-in).
23. Attach the oil cooler to the intake-side inner enclosure panel. Torque the bolts to 5.6 - 6.6 Nm (50 - 58 lb-in).
24. Install the remaining alternator ground strap bolt. Torque the bolts to 5 - 6.2 Nm (50 - 58 lb-in).
25. Install the alternator-end inner enclosure panel, on which the muffler is mounted. Torque the bolts to 5.6 - 6.6 Nm (50 - 58 lb-in).
26. Install the exhaust-side inner enclosure panel. Torque the bolts to 5.6 - 6.6 Nm (50 - 58 lb-in).
27. Install the muffler. Torque the mounting bolts to 9.8 - 11.9 Nm (87 - 105 lb-in). Torque the clamp bolts to 13.9 - 16.8 Nm (123 - 149 lb-in).
28. Install the alternator fan. Torque the nut on the through-stud to 113 - 139 Nm (83.62 - 102.86 ft-lb).

**NOTICE**

**To prevent alternator rotation when tightening the rotor nut, place the piece of 2x4 as shown in the figure below.**



**FIGURE 54. BLOCKING THE ALTERNATOR FOR INSTALLATION**

29. While viewing from the non-drive end, torque the stator through-bolt nuts as follows, with a progression of 2 o'clock, 8 o'clock, 10 o'clock, and 4 o'clock each time:

<b>Initial</b>	27 - 33 Nm (19.9 - 24.3 lb-ft)
<b>Final</b>	38 - 42 Nm (28 - 31 lb-ft)

30. Install the brush block assembly (if required). Torque the mounting bolts to 2.3 - 3.2 Nm (20 - 28 lb-in).
31. Connect the brushes to the wiring harness.
32. Reconnect AC accessory power wiring to terminal blocks TB-LINE and TB-NEUTRAL, as well as ground. Do not turn the power on for the AC accessory power connections.
33. Install the top access panels.
34. Connect the battery charger (BC-P).
35. Reconnect the battery heater (if present) to the wiring harness.
36. Connect the display at plug P1.
37. Mount the wiring harness onto the intake-side inner enclosure panel.
38. Install the alternator-end panel. Torque the bolts to 5.6 - 6.6 Nm (50 - 58 lb-in).



39. Install the crossbars and the hood assembly. Torque the bolts to 5.6 - 6.6 Nm (50 - 58 lb-in).
40. Install the battery and battery cables.
41. Install the intake and exhaust enclosure panels. Torque the bolts to 5.6 - 6.6 Nm (50 - 58 lb-in).
42. Make sure all bolts have been tightened to the correct torque, and all wiring harness connections have been made.
43. Make sure all components have been installed correctly.
44. Make sure the wiring harness routing does not interfere with the moving parts.
45. Restore power to the AC accessories.
46. Turn the fuel supply on.
47. Open the generator set circuit breaker to prevent load transfer to the generator set.
48. Start and run the generator set for at least one minute.
49. Stop the generator set. Troubleshoot any fault codes that appear.
50. Test system functionality by doing the following:
  - a. Close the generator set breaker.
  - b. Place the generator set in standby mode.
  - c. Open the main utility breaker connected to the transfer switch (if it is safe to do so). The generator set will start, and the transfer switch will transfer power to the generator set.
51. Close the main utility breaker. The transfer switch will transfer power back to the utility and enter engine cooldown mode. The engine will stop automatically in approximately 10 minutes.

## Torque Specifications

Area	Component	Metric	Imperial
Alternator	Alternator Fan/Rotor Retention Nut	113 - 139 Nm	83.3 - 102.5 lb-ft
Alternator	Alternator Ground Strap/B - to End Bell Bolt	12.3 - 15 Nm	109 - 133 lb-in
Alternator	Alternator Heater	18 - 22 Nm (or 1.5 to 2 turns past finger-tight)	13.3 - 16.2 lb-ft
Alternator	Brush Block Access Panel (Plastic) Bolt	3.2 - 4 Nm	28 - 35 lb-in
Alternator	Brush Block Bolts	2.3 - 3.2 Nm	20 - 28 lb-in
Alternator	Isolator Bolts - Alternator	24 - 29 Nm	17.7 - 24.1 lb-ft

Area	Component	Metric	Imperial
Alternator	Stator Through-Bolt Nuts	27 - 33 Nm*	19.9 - 24.3 lb-ft*
Alternator	Stator Through-Bolt Nuts	38 - 42 Nm*	28 - 31 lb-ft*
Alternator	Alternator Ground Strap to Skid Bolt	5 - 6.2 Nm*	50 - 58 lb-in*
Alternator	Alternator Leads into Circuit Breaker	4 - 5 Nm	35 - 44 lb-in
Alternator	Alternator Leads into Circuit Breaker: Bonding Jumper	4 - 5 Nm	35 - 44 lb-in
Alternator	Alternator Leads into Circuit Breaker: Neutral Lead/Lug Bolt	5.5 - 6.5 Nm	49 - 57 lb-in
Alternator	Alternator Leads into Circuit Breaker: Neutral Lug Hex Screw	4 - 5 Nm	35 - 44 lb-in
Enclosure	AC Battery Charger Screws	0.9 - 1.2 Nm	8 - 10.5 lb-in
Enclosure	Control Board Bracket to Enclosure Bolt	9.8 - 11.9 Nm	87 - 105 lb-in
Enclosure	Control Board to Bracket Mounting Bolt	2.8 - 3.5 Nm	25 - 31 lb-in
Enclosure	Enclosure Hood Hinge Assembly Bolts	5.6 - 6.6 Nm	50 - 58 lb-in
Enclosure	Enclosure M6 Bolts - All Panel Connections and Cross Bars	5.6 - 6.6 Nm	50 - 58 lb-in
Enclosure	Exhaust Baffle to Muffler Clamp Nuts	13.9 - 16.8 Nm	123 - 149 lb-in
Enclosure	Hood Latch Bolt	5.6 - 6.6 Nm	50 - 58 lb-in
Enclosure	Inner Enclosure Panel to Skid Nuts/Bolts	5.6 - 6.6 Nm	50 - 58 lb-in
Enclosure	Lower Fuel System Mounting Bolts	9.8 - 11.9 Nm	87 - 105 lb-in
Enclosure	Muffler Mounting Bolts	9.8 - 11.9 Nm	87 - 105 lb-in
Enclosure	Oil Cooler Bolts	5.6 - 6.6 Nm	50 - 58 lb-in
Enclosure	Service Access Panel Bolts	5.6 - 6.6 Nm	50 - 58 lb-in
Enclosure	Solenoid Mounting Bracket Bolts	9.8 - 11.9 Nm	87 - 105 lb-in
Engine	Airbox Cover Bolts	3.2 - 4.0 Nm	28 - 35 lb-in
Engine	Airbox Mounting Brackets Bolts	3.2 - 4.0 Nm	28 - 35 lb-in
Engine	Airbox to Mixer/Throttle Body Nuts	3.2 - 4.0 Nm	28 - 35 lb-in
Engine	Crankcase Reed Valve Cover Bolts	8 - 12 Nm	71 - 106 lb-in
Engine	Dipstick (Shipped Separately)	9.8 - 11.9 Nm*	87 - 105 lb-in*
Engine	Exhaust Manifold Nuts	33 - 40 Nm	24.3 - 29.5 lb-ft
Engine	Flywheel Nut	90 - 105 Nm	66.4 - 77.4 lb-ft
Engine	Governor Actuator Bracket to Engine Bolts	5.0 - 6.2 Nm	44 - 55 lb-in

Area	Component	Metric	Imperial
Engine	Governor Actuator Mounting Bolts	9.8 - 11.9 Nm	87 - 105 lb-in
Engine	Battery Charge Alternator Mounting Bolts	8 - 12 Nm	71 - 106 lb-in
Engine	Head Bolts	50 - 55 Nm	36.9 - 40.6 lb-ft
Engine	Rocker Arm Retainer Nut (Remove For Compression Test)	10 - 12 Nm	71 - 106 lb-in
Engine	Starter Mounting Bolts	25 - 30 Nm	18.4 - 22.1 lb-ft
Engine	Valve Cover Bolts	8 - 12 Nm	71 - 106 lb-in
Engine	Voltage Regulator Mounting Nuts	8 - 12 Nm	71 - 106 lb-in
Engine	Intake Manifold Nuts (Locking Feature of Nut Faces Outward)	11 - 14 Nm	97 - 124 lb-in
Engine	Isolator Bolts - Engine	24 - 29 Nm	17.7 - 24.1 lb-ft
Engine	Mixer Fuel Inlet Fitting/Lock Nut	58.3 - 77.3 Nm*	43 - 57 lb-ft*
Engine	Reed Valve Bolt	8 - 12 Nm	71 - 106 lb-in
Engine	Shield Bolts (Left and Right Side)	8 - 12 Nm	71 - 106 lb-in
Engine	Spark Plugs	25 - 30 Nm	18.4 - 22.1 lb-ft
Engine	Starter B+ Terminal	8 - 10 Nm*	71 - 89 lb-in*
Other	Battery Tray Bolt	3.2 - 4 Nm	28 - 35 lb-in

\*See the special instructions in the Alternator and Engine Removal and Installation section.

## 6.6 Placing the Generator Set Back in Service

If the control board is replaced, it will be necessary to configure the replacement control board. See the "Generator Config" Screen section for more information.

When all service and maintenance is completed on the generator set, the generator set control should be set to standby if it is safe to do so, or to an alternate state if requested by the customer.

## 6.7 Transfer Switch

### WARNING

***Interconnecting the generator set and the public utility can lead to the electrocution of personnel working on the utility lines, damage to equipment and fire. An approved switching device must be used to prevent interconnections.***

For information regarding servicing the transfer switch, see the appropriate transfer switch owner manual.

## 6.8 Line Circuit Breaker Troubleshooting

### WARNING

#### ***Automated Machinery***

***Accidental or remote starting of the generator set can cause severe personal injury or death.***

***Isolate all auxiliary supplies and use an insulated wrench to disconnect the starting battery cables, negative (-) cable first. Make sure the generator set is safely locked out of service to prevent disconnecting wires while the set is running***

1. Make sure the generator set is shut down and disabled:
  - a. Press the generator set's red STOP button on the local display to stop the generator set. Allow the generator set to thoroughly cool to the touch.
  - b. Turn off and disconnect the battery charger from the AC source before disconnecting the battery cables.
  - c. Disconnect the negative (-) cable from the battery and secure it from contacting the battery terminals to prevent accidental starting.
  - d. Once work is complete, reconnect the negative (-) battery cable last.
2. Disconnect the leads going into and out of the circuit breaker. There are two sets of leads:
  - One set of two leads from the alternator that is installed in the lugs at the top of the breaker (L1 and L2)
  - One set of two leads from the customer wiring that is installed in the lugs at the bottom of the breaker (L1 and L2)
3. Check continuity as follows:
  - When the breaker is on (that is, the contacts inside the breaker are closed), the continuity check should show very low resistance between the pair of L1 lugs and the pair of L2 lugs.
  - When the breaker is off (that is, the contacts inside the breaker are open), the continuity check between L1 and L2 pairs should show open.

The breaker should be replaced if either of the continuity tests fail.

# 7 Troubleshooting

---

## 7.1 Troubleshooting Procedures

This section is a guide to help you evaluate problems with the generator set. You can save time if you read through the entire manual ahead of time and understand the system.

This section contains the following information:

- How to troubleshoot symptom-based problems that are not numbered
- How to troubleshoot numeric fault codes, including descriptions of warning and shutdown code and corrective actions, such as checking fluid levels, control reset functions, battery connections, etc.

Make sure the generator set is shut down and disabled before disconnecting or connecting harness connectors to troubleshoot.

1. Press the generator set's "O" (Off) button to stop the generator set. Allow the generator set to thoroughly cool to the touch.
2. If applicable, turn off and disconnect the battery charger from the AC source before disconnecting the battery cables.
3. Disconnect the negative (–) cable from the battery and secure it from contacting the battery terminals to prevent accidental starting.

### NOTICE

**It is recommended that all changes to settings be recorded at each site to help troubleshoot the generator set.**

### NOTICE

**Electrostatic discharge will damage circuit boards. Always wear a wrist strap when handling circuit boards or when disconnecting or connecting harness connectors.**

## 7.2 Safety Considerations

### WARNING

#### ***Hazardous Voltage***

***Contact with high voltages can cause severe electrical shock, burns, or death.***

***Make sure that only personnel who are trained and qualified to work on this equipment are allowed to operate the generator set and perform maintenance on it.***

**⚠ WARNING****Combustible Gases**

**Ignition of battery gases is a fire and explosion hazard which can cause severe personal injury or death.**

**Do not smoke, or switch the trouble light ON or OFF near a battery. Touch a grounded metal surface first before touching batteries to discharge static electricity. Stop the generator set and disconnect the battery charger before disconnecting battery cables. Using an insulated wrench, disconnect the negative (-) cable first and reconnect it last.**

**⚠ WARNING****Automated Machinery**

**Accidental or remote starting of the generator set can cause severe personal injury or death.**

**Isolate all auxiliary supplies and use an insulated wrench to disconnect the starting battery cables (negative [-] first).**

Only trained and experienced service personnel with knowledge of fuels, electricity, and machinery hazards should perform service procedures. Review the safety precautions in the Important Safety Instructions section.

High voltages are present when the generator set is running. Do not open the generator set enclosure while the generator set is running.

**NOTICE**

**Disconnect the battery charger from the AC source before disconnecting the battery cables. Otherwise, disconnecting cables can result in voltage spikes damaging the generator set control.**






When troubleshooting a generator set, do the following to prevent an accidental restart:

1. Make sure the generator set is not in Remote or Standby mode.
2. Turn off or remove AC power from the battery charger.
3. Using an insulated wrench, remove the negative (-) battery cable from the generator set starting battery.

## 7.3 GATRR Troubleshooting Approach

Cummins Inc. recommends Service Training based on the GATRR (Gather, Analyze, Test, Repair, Retest) troubleshooting approach.

**TABLE 16. GATRR TROUBLESHOOTING APPROACH**

Icon	Description
	<p><b>G - Gather:</b> Gather customer information, review service history, complete visual inspection, and perform system operation check. Attempt to safely recreate the issue.</p>
	<p><b>A - Analyze:</b> Narrow down the possibilities by system and identify likely problem components.</p>
	<p><b>T - Test:</b> Perform tests in order of likelihood based on troubleshooting trees and symptoms present.</p>
	<p><b>R - Repair:</b> If necessary, perform repair per manufacturing guidelines and document all of the steps taken.</p>
	<p><b>R - Re-test:</b> Re-test the component, verify that the unit operates properly, and ensure that the documentation is complete.</p>

## 7.4 Tools and Parts Required

Tools and parts required include the following:

- Inpower Service Tool including:
  - Harness kit A001L533 (includes InPower harness A044M377 and RS232 to RS485 converter)
  - Brainbox™ USB to Serial port converter (PN A053T968) is required if you do not have a serial port available.
- Rotor removal tool (see the Rotor Removal Tool Fabrication section)
- Manometer or digital pressure gauge accurate to 0.01 in water column

- Alternator and engine removal and installation:
  - Tools:
    - Piece of standard 2 x 4 lumber cut to 4 in
    - Socket or similar tool less than 18.6 mm (0.73 in) in diameter
    - Wheel/gear puller
    - Rotor removal tool (see Rotor Removal Tool Fabrication section)
  - Parts:
    - Nut (M12 x 1.75)
    - Bolt (M14 x 2.0)
    - Intake manifold gaskets (4)
    - Throttle body to airbox gasket
    - Throttle body to intake manifold gasket
    - Exhaust manifold gaskets (2)
    - Engine oil (see the Model Specifications section)

## 7.5 Troubleshooting with the Local or Remote Displays

If a fault shutdown occurs, the FAULT light on the local or remote display will come on and the screen will display a description of the fault, the fault code number, and the total hours of generator set running time when the fault occurred.

The shutdown codes are listed below in numerical order along with step-by-step corrective actions.

The SERVICE light on the local or remote display will come on only to notify the homeowner of the following:

- A required maintenance interval,
- If a low oil level is detected, or
- If low battery voltage is detected

## 7.6 Utility-Powered Battery Charger Troubleshooting

### WARNING

#### ***Combustible Gases***

***Batteries can explode, causing severe skin and eye burns, and can release toxic electrolytes.***

***Do not dispose of the battery in a fire, because it is capable of exploding. Do not open or mutilate the battery.***



**⚠ WARNING****Electric Shock Hazard**

**Batteries present the risk of high short circuit current.**

**Remove watches, rings, or other metal objects. Use tools with insulated handles.**

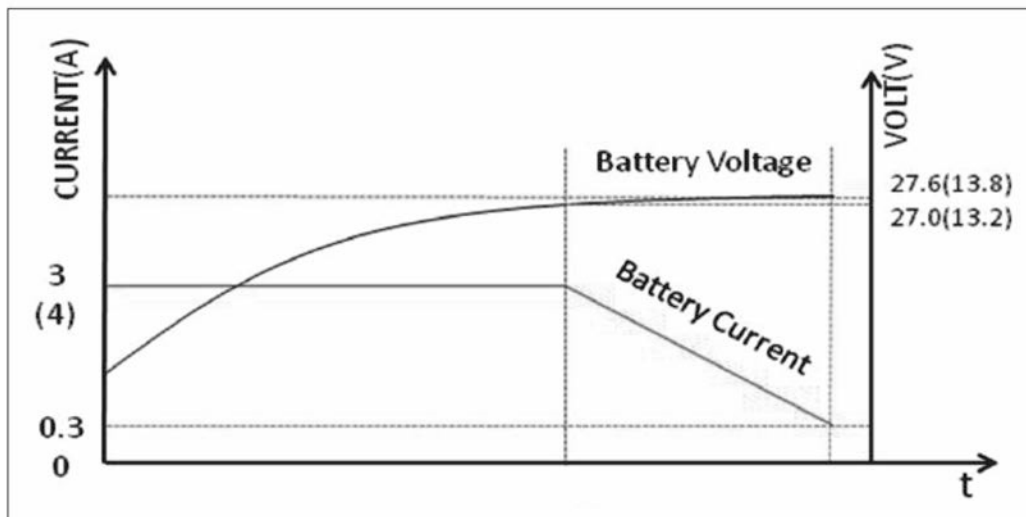
**NOTICE**

**Servicing of batteries must be performed or supervised by personnel knowledgeable of batteries and the required precautions. Keep unauthorized personnel away from batteries.**

When the battery voltage falls below approximately 13.2 VDC, the charging current will be constant at 4 Amps. When the battery voltage reaches 13.2 VDC, the charger automatically returns to float mode. As soon as the charging current value falls below 0.3 Amp, the charging indicator will turn off.

There are two LED indicator functions:

- **POWER:** power supply indicator, illuminated when the charger is connected to AC power.
- **CHARGING:** charging indicator, illuminated when charging current exceeds 0.3 Amps.



**FIGURE 55. UTILITY-POWERED BATTERY CHARGING CURVE**

**TABLE 17. TROUBLESHOOTING**

<b>Problem</b>	<b>Possible Causes</b>	<b>Action</b>
No Charger Output and Low Battery	No AC power	Check the supply breaker.
	Blown fuse	Replace the 5 Amp fuse (standard type ATO automotive). See the figure below for the fuse location between the voltage regulator and magnetos in the wiring.
	Charger failure (see the charge curve)	Check the LEDs and wiring; replace the charger if required.
Low Battery Voltage (Less Than 13.2 VDC)	Current is less than 2 Amps	Replace the charger.
	Charging LED is not on when expected	
	Total DC loads are greater than 4 Amps	Reduce DC loads below 4 Amps.
	Recent utility outage	Replace the battery if the voltage is not increasing with positive charge current.
	Failed generator set flywheel charger	
High Battery Voltage (Greater than 15 VDC)	Charger failure	Determine if the overcharge is from the utility-powered charger or from the generator set 9 Amp flywheel battery charger. Replace the appropriate battery charger.

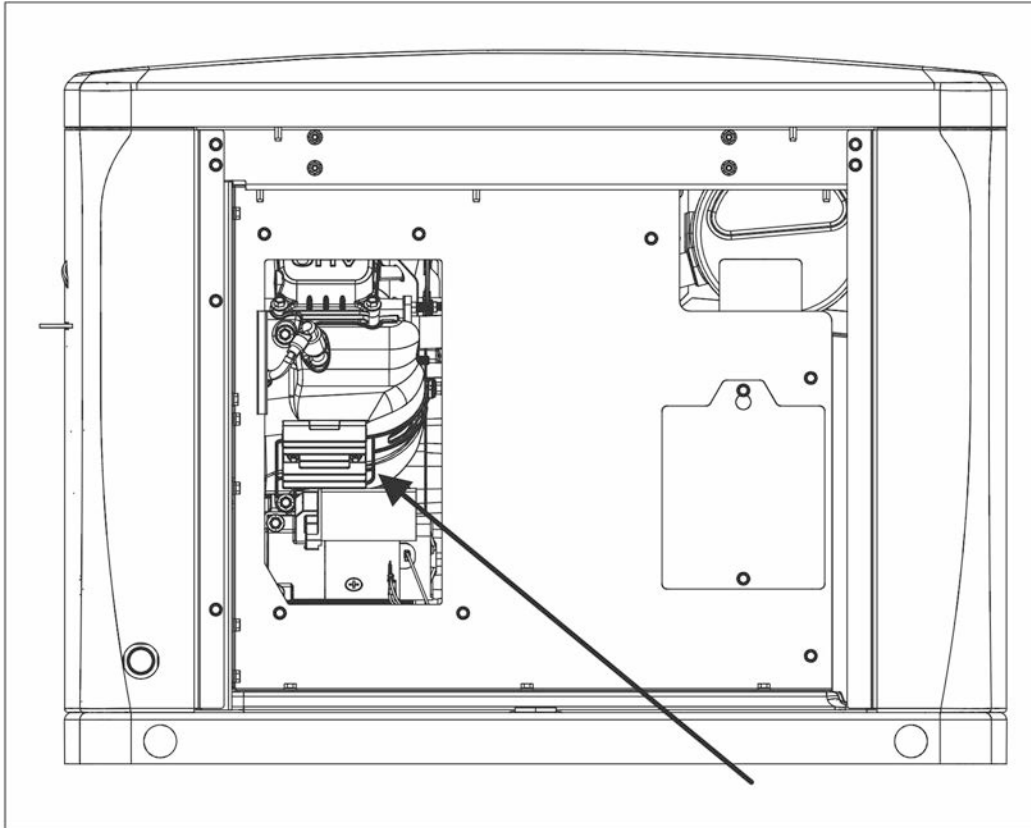


FIGURE 56. FUSE LOCATION

## 7.7 Engine Flywheel Battery Charger Troubleshooting

**⚠ WARNING**

***Combustible Gases***

***Batteries can explode, causing severe skin and eye burns, and can release toxic electrolytes.***

***Do not dispose of the battery in a fire, because it is capable of exploding. Do not open or mutilate the battery.***

**⚠ WARNING**

***Electric Shock Hazard***

***Batteries present the risk of high short circuit current.***

***Remove watches, rings, or other metal objects. Use tools with insulated handles.***

**NOTICE**

**Servicing of batteries must be performed or supervised by personnel knowledgeable of batteries and the required precautions. Keep unauthorized personnel away from batteries.**

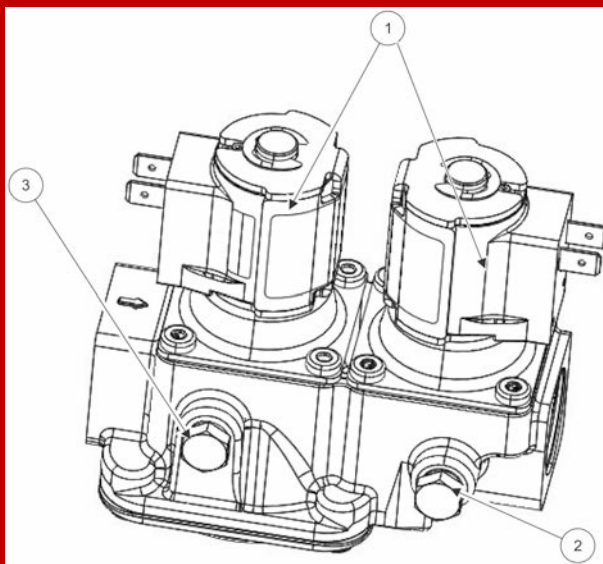
1. Remove utility power from the utility-power battery charger.
2. Attach a DC voltmeter to the battery and record the battery voltage while the generator set is not running.
3. Open the generator set's AC output breaker to prevent the ATS from transferring to generator set power.
4. Manually start the generator set.
5. Record the battery voltage with the generator set running.
6. Determine whether the running voltage is above or below the non-running voltage recorded in step 2.
  - If the DC voltage is higher than 14.3 VDC, verify that the supply voltage to the regulator is  $50 \pm 5$  VAC.
    - If the supply voltage is  $50 \pm 5$  VAC, replace the voltage regulator.
  - If the running voltage is at or the below non-running voltage:
    - a. Shut off the generator set and verify that the flywheel charger's 20 Amp in-line fuse is not open. It is located near the engine starter.
    - b. If the fuse is not blown, attach an ammeter to the red, fused output lead of the flywheel charger voltage regulator.
7. Restart the generator set.
8. Confirm that the charger output is positive but under 9 Amps whenever battery voltage is less than  $13.8 \pm 0.5$  VDC.
  - a. If the charger output is positive and under 9 Amps whenever battery voltage is less than  $13.8 \pm 0.5$  VDC, no further action needs to be taken.
  - b. If there is no output and battery voltage is less than  $13.8 \pm 0.5$  VDC, stop the generator set and disconnect the 4-pin plug going to the flywheel regulator.
    - i. Connect an AC voltmeter across the pins of the plug connected to the yellow wires supplying AC power to the regulator from the flywheel alternator.
    - ii. Verify  $50 \pm 5$  VAC across the yellow wires.
      - If  $50 \pm 5$  VAC is not available:
        - Verify that the blue wire of the flywheel alternator is at ground.
        - If  $50 \pm 5$  VAC is still not available, replace the flywheel alternator.
      - If  $50 \pm 5$  VAC is available, replace the voltage regulator.

## 7.8 Fuel Shutoff Solenoid Valve

When the engine is cranking or running, 12 VDC battery voltage is sent to the solenoid energizing the coil and causing the solenoid to retract (open) the valve. When the engine is stopped, the 12 VDC is removed, causing the valve to close and preventing any fuel from passing through.

The fuel shutoff solenoid for this product has two independent shutoff valves packaged as a single part.

There are two pressure ports on each side of the solenoid. The inlet and outlet valve flange also include a pressure port. The two in-line pressure ports on the valve body side correspond to each flange pressure port. The corresponding side and flange ports will give the same pressure reading. The top valve body side pressure port measures the pressure between the two shut-off valves. This port is used to determine if the first valve is leaking.



No.	Description	No.	Description
1	Solenoid Coils	3	Fuel (Supply Side) Pressure Port ahead of Shutoff Valves
2	Fuel Pressure Port after Shutoff Valve*		

\* Another fuel pressure port is on the far side, which is not shown.

**FIGURE 57. FUEL SHUTOFF SOLENOID VALVE**

---

## 7.9 Troubleshooting by Symptom

### Generator Set Starts when Utility Power Is Available - No Fault Code

**Logic:** To start - the generator set control receives ground at start input on the generator set control board with Standby enabled, or from a remote display or monitoring system (web page or phone app) with Remote enabled.

**Possible Causes:**

- Shorted harness connection
- Faulty ATS signal or relay and "Standby" is enabled
- Remote enabled and start command sent from remote device (display, web page, phone app)

**Diagnosis and Repair:**

1. If Remote is enabled, a remote start signal may come from the remote monitoring system (website or phone app) or remote display. Discuss this with the customer to ensure this functionality is understood.
2. Disconnect the ATS start signal at customer connection TB6 (Remote Start Input).
3. Measure for continuity to GND of both TB6 and customer wiring.
4. If present, inspect the wiring from the ATS for a short to GND and refer to the appropriate RA series ATS owner manual for diagnosis of the ATS.
5. If there is continuity of TB6 to GND, locate the short to ground in the harness, and repair or replace the harness.

### Generator Set Stops without Command - No Fault Code

**Logic:** The generator set control receives a stop signal at the generator set control board.

**Possible Causes:**

- Loss of the Remote Start command
- A remote stop command from a remote monitoring device
- Low battery voltage

**Diagnosis and Repair:**

1. Check the last fault recorded.
  - a. If this fault has not been repaired, troubleshoot that fault.
  - b. If the fault has been repaired, continue the diagnosis.
2. A remote stop signal may come from the Remote Monitoring System (website or phone app) or remote display. Discuss this with the customer to ensure this functionality is understood.

3. Verify that both the battery voltage and condition are acceptable. Minimum voltage for display operation is 8V.
4. Measure battery voltage at the battery while attempting to start from the local or remote display.
  - a. Recharge or replace the battery if the voltage drops below 8 VDC.
  - b. Test and service the generator set battery charger.
5. Check electrolyte level and hydrometer reading in maintenance-type batteries.
  - a. Replace electrolyte if necessary.
  - b. Recharge or replace battery if necessary.
6. Measure ATS start signal circuit for open circuit at customer connection TB6.
  - a. Measure at TB4-1 of the ATS (RA series ATS models) for ground. If there is no ground, this indicates that the K2 relay is open. Verify if the utility is present. Replace the relay if necessary.
  - b. Remove P2 at the generator set control board and measure at P2-4 for ground. If no ground, isolate the open wiring and repair it.
7. Verify that the P1 and P2 pin sockets are fully inserted and inspect the pin socket condition for corrosion and acceptable condition of contact wipers. To check contact wipers, use one of the devices used below:
  - A mating pin connector
  - A pin gauge the same size as the mating control connector pin (0.045 in)
  - Any suitable device that will not damage the inside contact wipers of the pin socketIf necessary:
  - Clean, repair or replace any pin sockets.
  - Fully insert any partially inserted pin sockets.
8. Inspect the condition of P1 and P2 pins on the control board. If they are damaged or severely corroded, clean or repair if possible, or replace the control board.
9. When reconnecting the harness plug to the connector, ensure that P1 and P2 are fully seated next to each other.

## No Response - Fail to Crank

**Logic:** The control receives a start command but does not crank.

**Possible Causes:**

- Low or no battery voltage
- Poor battery connection
- Faulty battery
- Open harness connection

- Faulty control board
- Faulty starter

**Diagnosis and Repair:**

1. Attempt to replicate the fault.
  2. Measure the battery voltage at the battery, at the generator set, and at connector P1.
    - Reconnect, clean, repair, and replace connections as necessary.
  3. Measure the battery voltage at the generator set while starting from the local or remote display.
    - Recharge or replace the battery if the voltage drops below 8 VDC.
    - Test and service the generator set battery charger.
  4. Inspect the starter:
    - a. Verify B+ at the positive battery terminal of the starter.
    - b. Verify B+ at the positive terminal of the starter solenoid while attempting to crank.
    - c. If the battery has been verified as good, replace the faulty starter.
  5. Inspect the condition of the control board P1 and P2 pins. If they are damaged or severely corroded, clean or repair them if possible, or replace the control board.
  6. Reconnect the P1 and P2 connectors. When reconnecting the harness to the connector, make sure that the pair are fully seated next to each other.
  7. Test-run the generator set for start operation.
  8. Disconnect the generator set control P1 and P2 connectors.
  9. Verify that the P1 and P2 pin sockets are fully inserted and inspect the pin socket condition for corrosion and acceptable condition of contact wipers. To check contact wipers, use one of the devices below:
    - A mating pin connector
    - A pin gauge the same size as the mating control connector pin (0.045 in)
    - Any suitable device that will not damage the inside contact wipers of the pin socket
- If necessary:
- Clean, repair or replace any pin sockets.
  - Fully insert any partially inserted pin sockets.

**Starting Battery Runs Down or Low Battery Warning Is Active**

**Logic:** Low or no battery voltage, or Low Battery Voltage Warning



**Possible Causes:**

1. Marginal battery connections
2. Faulty battery
3. Charging system
4. Excessive cranking
5. DC fuel pressure regulator heater
6. Control electrical draw

**Diagnosis and Repair:**

1. Check the last fault recorded.
  - If this fault has not been repaired, troubleshoot that fault.
2. Measure battery voltage at the battery and at the positive battery post on the starter. If the voltage levels are not the same, go to the next step.
3. Inspect battery connections and cables for cleanliness, tightness, and damage.
  - Clean, tighten, and repair connections and cables as necessary.
4. Check electrolyte level and hydrometer reading in maintenance type batteries.
  - Replace electrolyte as necessary.
  - Recharge or replace the battery as necessary.
5. Verify that the utility-powered battery charger is powered and check operation. See the Utility-Powered Battery Charger Troubleshooting section.
6. Verify that the engine battery charger is functioning correctly. Measure battery voltage and check for voltage increase while the generator set is running.

**Starter Engages, Then Disengages**

**Logic:** Cranking voltage dips below 8 VDC; microprocessor aborts start attempt

**Possible Causes:**

- Battery connections
- Faulty battery
- Charging system

**Diagnosis and Repair:**

1. Measure battery voltage at the battery and at the positive battery post on the starter. If the voltage levels are not the same, go to the next step.
2. Measure battery voltage at the battery and the generator set.
3. Inspect battery connections and cables for cleanliness, tightness, and damage.
  - Clean, tighten, and repair connections and cables as necessary.
4. Check electrolyte level and hydrometer reading in maintenance type batteries.
  - Replace electrolyte as necessary.

- Recharge or replace the battery as necessary.
5. Verify that the utility-powered battery charger is powered and check operation. See the Engine Flywheel Battery Charger Troubleshooting section.
  6. Verify engine battery charger is functioning correctly. Measure battery voltage and check for voltage increase while the generator set is running.

## No AC Power but Generator Set Is Running

**Logic:** There is no AC power but the generator set is running

**Possible Causes:**

- The generator set circuit breaker has tripped due to an overload or short or was turned off
- The ATS failed to transfer to the generator set source

**Diagnosis and Repair:**

1. Measure AC voltage at the generator set side of the circuit breaker.
  - If the AC voltage is not between 230 and 240 VAC, navigate to the No AC Power but Generator Set Is Running fault in the control display for diagnostics.
  - If AC is available, and the breaker is on, verify AC voltage on the load side of the breaker. If there is no AC voltage, replace the breaker.
2. Measure the AC output at the generator set circuit breaker.
  - Reset or turn on the generator set circuit breaker.
  - Diagnose faulty loads as necessary.
3. Verify the transfer command is being sent to the ATS at customer connection TB5 (ATS control). Refer to the ATS owner manual if the ATS failed to transfer.

## 7.10 Troubleshooting with Fault Codes

### Fault Code Introduction

Fault code information, together with warning and shutdown information, is provided in this section to assist in locating and identifying the possible causes of faults in the generator set system.

Refer also to the engine-specific operator manual, if it exists. The engine operator manual contains additional information regarding the running and care of the generator set as well as specific equipment instructions that may differ from the standard generator set.

For any fault codes that occur but are not listed, contact your Cummins service representative.

## Code 2 - Low Oil Pressure Fault

**Logic:** Continuous ground (greater than or equal to 3 seconds) at the generator set control for oil pressure input. The switch opens the control circuit with pressure.

### Possible Causes:

- Low/high oil level
- Faulty oil pressure relief valve in engine
- Harness is faulty (unintentional ground in circuit)
- Faulty oil pump

### Diagnosis and Repair:

1. Check the last fault recorded.
  - If this fault has not been repaired, troubleshoot that fault.
2. Measure the oil level.
  - Add or drain oil if necessary.
3. Disconnect the plug from the oil pressure switch and measure continuity from P1-6 and GND. If there is circuit continuity, find and repair the short to ground in the harness from P1-6 to the oil switch connector.
4. Verify switch operation:
  - a. Check for continuity (ground) across the switch when the generator set is not running.
  - b. Check for open across the switch when the generator set is running.
  - c. Replace the switch if it is not working correctly.
5. Repair or replace the harness if necessary.
6. Measure oil pressure with a mechanical gauge.
  - Repair or replace the relief valve and oil pump if necessary.

## Code 4 - Overcrank

**Logic:** The generator set control did not sense alternator quad winding frequency after cycle crank (30 seconds of cranking and 15 seconds between each crank attempt for a total of 3 crank attempts).

### Possible Causes:

- Generator set did not start
- Fuel supply
- Air fuel mixture
- Wire connections
- Starter
- Ignition system
- Iced or corroded brushes or open/shorted excitation circuit

- Open/shorted quad sense or quad winding
- Failed AVR/field flash circuit
- Slow cranking speed

**Diagnosis and Repair:**

1. Check the last fault recorded.
    - If this fault has not been repaired, troubleshoot that fault.
  2. Disconnect the generator set control P1 connector.
  3. Verify that the P1 and P2 pin sockets are fully inserted and inspect the pin socket condition for corrosion and acceptable condition of contact wipers. To check contact wipers, use one of the devices below:
    - A mating pin connector
    - A pin gauge the same size as the mating control connector pin (0.045 in)
    - Any suitable device that will not damage the inside contact wipers of the pin socket
- If necessary:
- Clean, repair or replace any pin sockets.
  - Fully insert any partially inserted pin sockets.
4. Inspect the condition of P1 and P2 pins on the control board. If they are damaged or severely corroded, clean or repair if possible, or replace the control board.
  5. When reconnecting the harness plug to the connector, ensure that the pair are fully seated next to each other.
  6. Reconnect the P1 connector and test-run the generator set for fault occurrence.
  7. Verify the engine rotation manually.
    - Repair engine damage if necessary.
  8. Measure the DC voltage at the starter during start attempt.
    - Repair wire connections if necessary.
    - Replace the starter and solenoid assembly if necessary.
  9. Check air filter cleanliness.
    - Replace the air filter if necessary.
  10. Check for blocked or damaged exhaust system.
    - Repair or replace exhaust components if necessary.
  11. *Propane models only:*
    - a. When ambient temperatures are less than 4.4 °C (40 °F), the vapor withdrawal propane tanks should be at least half full to provide proper vaporization rate.

- 
- b. Propane that has more than 2.5% butane will not vaporize in ambient temperatures at less than 0 °C (32 °F) so make sure to use HD-5 grade propane.
  - c. Run the generator set on shop fuel supply; verify tank level and fuel line condition.
12. Verify that the fuel solenoids valves open.
  13. Measure DC voltage at the fuel solenoid while the generator set is attempting to start. Voltage must be greater than the threshold voltage of the solenoids (10.2 V). See the Fuel Shutoff Solenoid Troubleshooting section for more information.
    - Repair wiring if necessary.
  14. Check the generator set fuel lines and connections for leaks.
  15. Verify that the regulator is allowing fuel to pass. Check the regulator vent for obstructions.
  16. Measure the fuel supply pressure at the generator set.
  17. Check the governor actuator, actuator linkage, and throttle shaft for free smooth motion without slop. Verify that the actuator is opening the throttle while cranking.
  18. Check the engine ignition system:
    - a. Verify that the spark plug leads are fully installed on the spark plugs. Reconnect them if necessary.
    - b. Inspect the spark plug leads. Replace worn or damaged leads.

<b>NOTICE</b>
---------------

<b>Spark plug leads are only available as part of the coil assembly.</b>
--------------------------------------------------------------------------

- c. Check the magneto output:
    - i. Using a spark tester, verify that the magneto coils are providing acceptable output. If the output is not acceptable, verify the proper magneto gap, and re-gap if necessary.
    - ii. Verify that the magnet that is in the flywheel is still magnetic, is not damaged, and/or has not been misplaced. Repair it if necessary.
    - iii. If the magneto coil is still not functioning properly, replace it.
  - d. Inspect the spark plugs for damage and proper gap:
    - Remove and inspect spark plugs. If they are damaged or dirty, replace them.
    - Measure the spark plug gap. Re-gap if necessary.
19. Measure field, quadrature, and main winding resistance.
    - Clean the slip rings, replace the brushes, repair the harness, and replace the rotor or stator if necessary.

- 
20. Measure quad voltage during cranking. If below 50 VAC during cranking, inspect the excitation system. Field voltage should equal battery voltage (12 VDC nominal) during cranking. If not, replace the generator set control.

## Code 12 - Overvoltage

### Logic:

- *Instantaneous Fault:* AC voltage S1-S2 greater than 300 VAC
- *Delayed Fault:* AC voltage line-to-line greater than 268 VAC, but less than 300 VAC for 3 continuous seconds.

### Possible Causes:

- Generator set loads
- Wire connections
- Alternator windings

### Diagnosis & Repair:

1. Check the last fault recorded.
    - If this fault has not been repaired, troubleshoot that fault.
  2. Measure and verify the AC voltage at the generator set circuit breaker and at pins P1-34 and P1-35.
  3. Verify the AC frequency on the display, then measure it on a digital volt ohmmeter. Compare the two measurements to determine if the control is measuring frequency correctly.
  4. Cycle loads to determine if a particular load causes fault.
    - Diagnose faulty load if necessary.
  5. Remove connector P1 from the control and re-install it, and then start the generator set.
  6. Verify that the P1 pin socket is fully inserted and inspect the pin socket condition for corrosion and acceptable condition of contact wipers. To check contact wipers, use one of the devices below:
    - A mating pin connector
    - A pin gauge the same size as the mating control connector pin (0.045 in)
    - Any suitable device that will not damage the inside contact wipers of the pin socket
- If necessary:
- Clean, repair or replace the pin socket.
  - Fully insert any partially inserted pin socket.
7. Inspect the condition of the P1 pin on the control board. If it is damaged or severely corroded, clean or repair if possible, or replace the control board.
  8. When reconnecting the harness plug to the connector, ensure that the pair are fully seated next to each other.

9. Measure field, quadrature, and main winding resistance.
  - Clean the slip rings, replace the brushes, repair the harness, and replace the rotor or stator if necessary.

## Code 13 - Undervoltage

**Logic:** AC voltage 240 line-to-line is less than 216 VAC for 5 continuous seconds

### Possible Causes:

- Generator set loads
- Wire connections
- Alternator windings
- Generator set overload

### Diagnosis & Repair:

1. Check the last fault recorded.
    - If this fault has not been repaired, troubleshoot that fault.
  2. Measure and verify the AC voltage at the generator set circuit breaker and at pins P1-34 and P1-35.
  3. Measure and verify the AC frequency while changing the engine RPM to determine if the frequency response matches the engine RPM response.
  4. Cycle loads to determine if a particular load will cause fault.
    - Diagnose faulty load if necessary.
  5. Verify balanced loads in 120/240 VAC applications.
    - Balance loads within 10% line-to-line as required.
  6. Remove connector P1 from the control and re-install it, and then start the generator set.
  7. Verify that the P1 pin socket is fully inserted and inspect the pin socket condition for corrosion and acceptable condition of contact wipers. To check contact wipers, use one of the devices below:
    - A mating pin connector
    - A pin gauge the same size as the mating control connector pin (0.045 in)
    - Any suitable device that will not damage the inside contact wipers of the pin socket
- If necessary:
- Clean, repair or replace the pin socket.
  - Fully insert any partially inserted pin socket.
8. Inspect the condition of the P1 pin on the control board. If it is damaged or severely corroded, clean or repair if possible, or replace the control board.
  9. When reconnecting the harness plug to the connector, ensure that the pair are fully seated next to each other.

- 
10. Measure field, quadrature and main winding resistance.
    - Clean the slip rings, replace the brushes, repair the harness, and replace the rotor or stator if necessary.
  11. Check brush alignment:
    - a. Inspect brush wear on the slip rings and verify brush misalignment is toward the windings.
    - b. If misalignment is toward the bearing, the cause is not a tolerance issue, but is more likely the result of the end bell not being seated properly during assembly.
      - Inspect for cause and repair if necessary.

## Code 14 - Overfrequency

### Logic:

- *Instantaneous Fault:* Frequency greater than 72 Hz
- *Delayed Fault:* Frequency greater than 66 Hz, but less than 72 Hz, for 6 continuous seconds

### Possible Causes:

- Generator set loads
- Engine governor function
- Fuel supply
- Air fuel mixture
- Exhaust system
- Demand regulator
- Throttle plate
- Alternator windings
- Wire connections

### Diagnosis & Repair:

1. Check the last fault recorded.
  - If this fault has not been repaired, troubleshoot that fault.
2. Measure the AC current while running the generator set with loads.
  - Identify faulty or short cycling loads.
3. Measure the AC frequency while running.
4. Measure the AC frequency while changing the engine RPM to determine if the frequency response matches the engine RPM response.
5. Disconnect the generator set control P1 connector.



- 
6. Verify that the P1 pin sockets are fully inserted and inspect the pin socket condition for corrosion and acceptable condition of contact wipers. To check contact wipers, use one of the devices below:
    - A mating pin connector
    - A pin gauge the same size as the mating control connector pin (0.045 in)
    - Any suitable device that will not damage the inside contact wipers of the pin socket
  - If necessary:
    - Clean, repair or replace any pin sockets.
    - Fully insert any partially inserted pin sockets.
  7. Inspect the condition of P1 pins on the control board. If they are damaged or severely corroded, clean or repair if possible, or replace the control board.
  8. When reconnecting the harness plug to the connector, ensure that the pair are fully seated next to each other.
  9. Reconnect the P1 connector and test-run the generator set for fault occurrence.
  10. Check for a blocked or damaged exhaust system.
    - Repair or replace exhaust components if necessary.
  11. *Propane models only:*
    - a. When ambient temperatures are less than 40 °F (34.4 °C), vapor withdrawal propane tanks should be at least half full to provide the proper vaporization rate.
    - b. Propane having more than 2.5% butane will not vaporize in ambient temperatures at less than 32 °F (0 °C); use HD-5 grade propane.
    - c. Run the generator set on shop fuel supply; verify the tank level and fuel line condition.
  12. Measure steady DC voltage at the fuel solenoid while the generator set is running.
    - Repair wiring if necessary.
  13. Check the generator set fuel lines for damage.
    - Replace the fuel line if necessary.
  14. Check the governor actuator, actuator linkage, and throttle shaft for free smooth motion without slop. Verify that the actuator is opening the throttle while cranking.
  15. Measure the field, quadrature, and main winding resistance.
    - Clean the slip rings, replace the brushes, repair the harness, and replace the rotor or stator if necessary.
  16. Check brush alignment:
    - a. Inspect brush wear on the slip rings and verify brush misalignment is toward the windings.
-

- b. If the misalignment is toward the bearing, the cause is not a tolerance issue but is more likely the result of the end bell not being seated properly during assembly.
  - Inspect for cause and repair if necessary.

## Code 15 - Underfrequency

**Logic:** Frequency less than 54 Hz (for the 60 Hz model) for 8 continuous seconds.

### Possible Causes:

- Generator set loads
- Engine governor function
- Fuel supply
- Air fuel mixture
- Exhaust system
- Demand regulator
- Throttle plate
- Alternator windings
- Ignition
- Wire connections

### Diagnosis & Repair:

1. Check the last fault recorded.
    - If this fault has not been repaired, troubleshoot that fault.
  2. Measure the AC current while running the generator set with loads.
    - Identify faulty or short cycling loads.
  3. Measure the generator set load capability with load bank; derate for altitude and temperature if necessary.
  4. Measure the AC frequency while running.
  5. Disconnect the generator set control P1 connector.
  6. Verify that the P1 and P2 pin sockets are fully inserted and inspect the pin socket condition for corrosion and acceptable condition of contact wipers. To check contact wipers, use one of the devices below:
    - A mating pin connector
    - A pin gauge the same size as the mating control connector pin (0.045 in)
    - Any suitable device that will not damage the inside contact wipers of the pin socket
- If necessary:
- Clean, repair or replace any pin sockets.
  - Fully insert any partially inserted pin sockets.

- 
7. Inspect the condition of P1 and P2 pins on the control board. If they are damaged or severely corroded, clean or repair if possible, or replace the control board.
  8. When reconnecting the harness plug to the connector, ensure that the pair are fully seated next to each other.
  9. Reconnect the P1 connector and test-run the generator set for fault occurrence.
    - Repair or replace pins in the connector if necessary.
  10. Check for air filter cleanliness.
    - Replace the air filter if necessary.
  11. Check for a blocked or damaged exhaust system.
    - Repair or replace exhaust components if necessary.
  12. *Propane models only:*
    - a. When ambient temperatures are less than 40 °F (34.4 °C), vapor withdrawal propane tanks should be at least half full to provide the proper vaporization rate.
    - b. Propane having more than 2.5% butane will not vaporize in ambient temperatures at less than 32 °F (0 °C); use HD-5 grade propane.
    - c. Run the generator set on shop fuel supply; verify the tank level and fuel line condition.
  13. Measure steady DC voltage at the fuel solenoid while the generator set is running.
    - Repair wiring if necessary.
  14. Check the generator set fuel lines for damage.
    - Replace the fuel line if necessary.
  15. Measure the fuel supply pressures.
  16. Check the fuel pressure regulator outlet pressure. See the Checking and Adjusting the Fuel Pressure Regulator Outlet Pressure section.
  17. Check the governor actuator, actuator linkage, and throttle shaft for free smooth motion without slop. Verify that the actuator is opening the throttle while cranking.
  18. Measure field, quadrature, and main winding resistance.
    - Clean the slip rings, replace the brushes, repair the harness, and replace the rotor or stator if necessary.
  19. Check brush alignment:
    - a. Inspect brush wear on the slip rings and verify brush misalignment is toward the windings.

- b. If the misalignment is toward the bearing, the cause is not a tolerance issue but is more likely the result of the end bell not being seated properly during assembly.

- Inspect for cause and repair if necessary.

20. Check the engine ignition system:

- a. Verify that the spark plug leads are fully installed on the spark plugs. Reconnect them if necessary.
- b. Inspect the spark plug leads. Replace worn or damaged leads.

**NOTICE**

**Spark plug leads are only available as part of the coil assembly.**

c. Check the magneto output:

- i. Using a spark tester, verify that the magneto coils are providing acceptable output. If the output is not acceptable, verify the proper magneto gap, and re-gap if necessary.
- ii. Verify that the magnet that is in the flywheel is still magnetic, is not damaged, and/or has not been misplaced. Repair it if necessary.
- iii. If the magneto coil is still not functioning properly, replace it.

d. Inspect the spark plugs for damage and proper gap:

- Remove and inspect spark plugs. If they are damaged or dirty, replace them.
- Measure the spark plug gap. Re-gap if necessary.

21. Measure the temperature of the air intake and temperature rise across the generator set.

- Remove the blockage or prevent air recirculation if necessary.

## Code 19 - Governor Actuator Shutdown

**Logic:** Controller sensed governor actuator circuit is open or shorted.

**Possible Causes:**

- Wire connections
- Governor actuator

**Diagnosis & Repair:**

1. Check the last fault recorded.
  - If this fault has not been repaired, troubleshoot that fault.
2. Measure and verify governor actuator resistance (2.8 Ohms  $\pm$ 5%).
  - Replace if necessary.
3. Measure and verify governor wiring to the control.
  - Replace or repair if necessary.

4. Disconnect the generator set control P1 connector.
  5. Verify that the P1 pin socket is fully inserted and inspect the pin socket condition for corrosion and acceptable condition of contact wipers. To check contact wipers, use one of the devices used below:
    - A mating pin connector
    - A pin gauge the same size as the mating control connector pin (0.045 in)
    - Any suitable device that will not damage the inside contact wipers of the pin socket
- If necessary:
- Clean, repair or replace the pin socket.
  - Fully insert any partially inserted pin socket.
6. Inspect the condition of P1 pin on the control board. If it is damaged or severely corroded, clean or repair if possible, or replace the control board.
  7. When reconnecting the harness plug to the connector, ensure that the pair are fully seated next to each other.
  8. Reconnect the P1 connector and test-run the generator set for fault occurrence.

## **Code 22 - Governor Actuator Overload**

**Logic:** Maximum governor output (PWM) for 10 continuous seconds

**Possible Causes:**

- Generator set loads
- Wire connections
- Fuel supply
- Air fuel mixture
- Exhaust system
- Governor actuator
- Ignition system
- Elevated ambient temperature
- Cooling air flow blockage

**Diagnosis & Repair:**

1. Check the last fault recorded.
  - If this fault has not been repaired, troubleshoot that fault.
2. Measure the AC current while running the generator set with loads.
  - Identify faulty or short cycling loads.
3. Measure the generator set load capability with load bank; de-rate for altitude and temperature if necessary.
4. Disconnect the generator set control P1 connector.

- 
5. Verify that the P1 pin socket is fully inserted and inspect the pin socket condition for corrosion and acceptable condition of contact wipers. To check contact wipers, use one of the devices below:
    - A mating pin connector
    - A pin gauge the same size as the mating control connector pin (0.045 in)
    - Any suitable device that will not damage the inside contact wipers of the pin socket
  - If necessary:
    - Clean, repair or replace the pin socket.
    - Fully insert any partially inserted pin socket.
  6. Inspect the condition of the P1 pin on the control board. If it is damaged or severely corroded, clean or repair if possible, or replace the control board.
  7. When reconnecting the harness plug to the connector, ensure that the pair are fully seated next to each other.
  8. Reconnect the P1 connector and test-run the generator set for fault occurrence.
  9. Check for air filter cleanliness.
    - Replace the air filter if necessary.
  10. *Propane models only:*
    - When ambient temperatures are less than 40 °F (34.4 °C), vapor withdrawal propane tanks should be at least half full to provide the proper vaporization rate.
    - Propane having more than 2.5% butane will not vaporize in ambient temperatures at less than 32 °F (0 °C); use HD-5 grade propane.
    - Run the generator set on shop fuel supply; verify the tank level and fuel line condition.
  11. Check the generator set fuel lines for damage.
    - Replace the fuel line if necessary.
  12. Measure the fuel supply pressures.
  13. Check the intake manifold and gaskets for air leaks.
    - Tighten the fasteners.
    - Replace the gaskets and manifold if necessary.
  14. Check for a blocked or damaged exhaust system.
    - Repair or replace exhaust components if necessary.
  15. Verify the actuator function by applying DC voltage to the terminals.
    - Replace the actuator if necessary.
  16. Check the governor actuator, actuator linkage, and throttle shaft for free smooth motion without slop. Verify that the actuator is opening the throttle while cranking.
-

---

17. Check the engine ignition system:

- a. Verify that the spark plug leads are fully installed on the spark plugs. Reconnect them if necessary.
- b. Inspect the spark plug leads. Replace worn or damaged leads.

<b>NOTICE</b>
---------------

<b>Spark plug leads are only available as part of the coil assembly.</b>
--------------------------------------------------------------------------

- c. Check the magneto output:
  - i. Using a spark tester, verify that the magneto coils are providing acceptable output. If the output is not acceptable, verify the proper magneto gap, and re-gap if necessary.
  - ii. Verify that the magnet that is in the flywheel is still magnetic, is not damaged, and/or has not been misplaced. Repair it if necessary.
  - iii. If the magneto coil is still not functioning properly, replace it.
- d. Inspect the spark plugs for damage and proper gap:
  - Remove and inspect spark plugs. If they are damaged or dirty, replace them.
  - Measure the spark plug gap. Re-gap if necessary.

## Code 27 - Voltage Sense Lost

**Logic:** The generator set frequency is greater than 40 Hz and voltage sensed is less than 5 VAC on one or both lines. (The control senses if one line is lost or disconnected.)

### Possible Causes:

- Generator set loads
- Alternator windings
- Wire connections

### Diagnosis & Repair:

1. Check the last fault recorded.
  - If this fault has not been repaired, troubleshoot that fault.
2. Measure the AC voltage.
3. Disconnect the generator set control P1 connector.
4. Verify that the P1 and P2 pin sockets are fully inserted and inspect the pin socket condition for corrosion and acceptable condition of contact wipers. To check contact wipers, use one of the devices below:
  - A mating pin connector
  - A pin gauge the same size as the mating control connector pin (0.045 in)

- Any suitable device that will not damage the inside contact wipers of the pin socket
- If necessary:
- Clean, repair or replace any pin sockets.
  - Fully insert any partially inserted pin sockets.
5. Inspect the condition of P1 and P2 pins on the control board. If they are damaged or severely corroded, clean or repair if possible, or replace the control board.
  6. When reconnecting the harness plug to the connector, ensure that the pair are fully seated next to each other.
  7. Reconnect the P1 connector and test-run the generator set for fault occurrence.
  8. Measure field, quadrature, and main winding resistance.
    - Clean the slip rings, replace the brushes, repair the harness, and replace the rotor or stator if necessary.
  9. Check brush alignment:
    - a. Inspect brush wear on the slip rings and verify brush misalignment is toward the windings.
    - b. If the misalignment is toward the bearing, the cause is not a tolerance issue but is more likely the result of the end bell not being seated properly during assembly.
      - Inspect for cause and repair if necessary.

## Code 29 - High Battery Voltage

**Logic:** DC voltage to controller greater than 19 VDC.

### Possible Causes:

- Incorrect battery configuration
- Wire damage
- Faulty charger
- Control

### Diagnosis & Repair:

1. Check the last fault recorded.
  - If this fault has not been repaired, troubleshoot that fault.
2. Measure DC voltage at the battery, at the generator set, and at connector P1.
  - Reconnect the battery or repair wiring if necessary.
3. Measure DC voltage with the battery charger turned on.
  - Diagnose the faulty charger.
4. Disconnect the generator set control P1 connector.



5. Verify that the P1 pin socket is fully inserted and inspect the pin socket condition for corrosion and acceptable condition of contact wipers. To check contact wipers, use one of the devices below:
  - A mating pin connector
  - A pin gauge the same size as the mating control connector pin (0.045 in)
  - Any suitable device that will not damage the inside contact wipers of the pin socket
- If necessary:
  - Clean, repair or replace the pin socket.
  - Fully insert any partially inserted pin socket.
6. Inspect the condition of the P1 pin on the control board. If it is damaged or severely corroded, clean or repair if possible, or replace the control board.
7. When reconnecting the harness plug to the connector, ensure that the pair are fully seated next to each other.
8. Reconnect the P1 connector and test-run the generator set for fault occurrence.

## **Code 32 - Low Cranking Speed Sense**

**Logic:** Quadrature frequency is less than 1 Hz (engine RPM is less than 180) for 3 continuous seconds after pressing start

### **Possible Causes:**

- Starter, engine components
- Air intake system
- Exhaust system
- Alternator windings
- Wire connections
- Battery
- Battery connections
- Oil viscosity
- Iced or corroded slip rings

### **Diagnosis & Repair:**

1. Check the last fault recorded.
  - If this fault has not been repaired, troubleshoot that fault.
2. Measure battery voltage at the battery and the generator set.
  - Recharge or replace the battery as necessary.
3. Verify the engine rotation manually.
  - Repair engine damage as necessary.

- 
4. Verify the alternator rotation manually.
    - Repair alternator damage as necessary.
  5. Disconnect the generator set control J1 connector.
  6. Verify the J1 pins are fully inserted, and inspect pin condition (pins 2 and 3 for quad, and pins 1 and 13 for field) using one of the devices below:
    - A mating pin connector
    - A pin gauge of the same size as the mating control connector pin (0.045 in)
    - Any suitable device that will not damage the inside contact wipers of the pin socket
- Insert, repair, or replace pins as necessary.
7. Inspect the condition of the P1 pin on the control board. If it is damaged or severely corroded, clean or repair if possible, or replace the control board.
  8. When reconnecting the harness plug to the connector, ensure that the pair are fully seated next to each other.
  9. Measure DC voltage at the starter during a start attempt.
    - a. Repair wire connections as necessary.
    - b. Replace the start solenoid and starter as necessary.
  10. Check for air filter cleanliness.
    - Replace the air filter as necessary.
  11. Check for a blocked or damaged exhaust system.
    - Repair or replace exhaust components as necessary.
  12. *Propane models only:*
    - a. When ambient temperatures are less than 40 °F (34.4 °C), vapor withdrawal propane tanks should be at least half full to provide the proper vaporization rate.
    - b. Propane having more than 2.5% butane will not vaporize in ambient temperatures at less than 32 °F (0 °C); use HD-5 grade propane.
    - c. Run the generator set on shop fuel supply; verify the tank level and fuel line condition.
  13. Measure steady DC voltage at the fuel solenoid while the generator set is running.
    - Repair wiring as necessary.
  14. Verify the vent hose is clear.
  15. Check the generator set fuel lines for damage.
    - Replace the fuel line as necessary.
  16. Measure the fuel supply pressures.
-

17. Check the governor actuator, actuator linkage, and throttle shaft for free smooth motion without slop. Verify that the actuator is opening the throttle while cranking.
18. Check the engine ignition system:
  - a. Verify that the spark plug leads are fully installed on the spark plugs. Reconnect them if necessary.
  - b. Inspect the spark plug leads. Replace worn or damaged leads.

**NOTICE****Spark plug leads are only available as part of the coil assembly.**

- c. Check the magneto output:
  - i. Using a spark tester, verify that the magneto coils are providing acceptable output. If the output is not acceptable, verify the proper magneto gap, and re-gap if necessary.
  - ii. Verify that the magnet that is in the flywheel is still magnetic, is not damaged, and/or has not been misplaced. Repair it if necessary.
  - iii. If the magneto coil is still not functioning properly, replace it.
- d. Inspect the spark plugs for damage and proper gap:
  - Remove and inspect spark plugs. If they are damaged or dirty, replace them.
  - Measure the spark plug gap. Re-gap if necessary.

## Code 35 - Control Card Failure

**Logic:** EEPROM (programming variables) error during self-test

**Possible Causes:** Faulty program

**Diagnosis & Solution:**

1. Check the last fault recorded.
  - If this fault has not been repaired, troubleshoot that fault.
2. Replace the control.

## Code 36 - Generator Set Stopped Without Fault Condition

**Logic:** RPM is less than 500 and sense voltage S1-S2 is at 0 VAC and no other fault condition occurred

**Possible Causes:**

- Fuel supply
- Air fuel mixture
- Exhaust system
- Demand regulator

- Throttle plate
- Alternator windings
- Ignition
- Wire connections

**Diagnosis & Repair:**

1. Check the last fault recorded.
  - If this fault has not been repaired, troubleshoot that fault.
2. Verify the engine rotation manually.
  - Repair engine damage as necessary.
3. Verify the alternator rotation manually.
  - Repair alternator damage as necessary.
4. Disconnect the generator set control J1 connector.
5. Verify the J1 pins are fully inserted, and inspect pin condition using one of the devices below:
  - A mating pin connector
  - A pin gauge of the same size as the mating control connector pin (0.045 in)
  - Any suitable device that will not damage the inside contact wipers of the pin socketInsert, repair, or replace pins as necessary.
6. Inspect the condition of the P1 pin on the control board. If it is damaged or severely corroded, clean or repair if possible, or replace the control board.
7. When reconnecting the harness plug to the connector, ensure that the pair are fully seated next to each other.
8. Check for air filter cleanliness.
  - Replace the air filter as necessary.
9. Check for a blocked or damaged exhaust system.
  - Repair or replace exhaust components as necessary.
10. Measure the generator set load capability with a shop load bank.
11. *Propane models only:*
  - a. When ambient temperatures are less than 40 °F (34.4 °C), vapor withdrawal propane tanks should be at least half full to provide the proper vaporization rate.
  - b. Propane having more than 2.5% butane will not vaporize in ambient temperatures at less than 32 °F (0 °C); use HD-5 grade propane.
  - c. Run the generator set on shop fuel supply; verify the tank level and fuel line condition.

12. Measure steady DC voltage at the fuel solenoid while the generator set is running.
  - Repair wiring as necessary.
13. Verify the vent hose is clear.
14. Check the generator set fuel lines for damage.
  - Replace the fuel line as necessary.
15. Measure the fuel supply pressures.
16. Check the governor actuator, actuator linkage, and throttle shaft for free smooth motion without slop. Verify that the actuator is opening the throttle while cranking.
17. Check the engine ignition system:
  - a. Verify that the spark plug leads are fully installed on the spark plugs. Reconnect them if necessary.
  - b. Inspect the spark plug leads. Replace worn or damaged leads.

**NOTICE**

**Spark plug leads are only available as part of the coil assembly.**

- c. Check the magneto output:
  - i. Using a spark tester, verify that the magneto coils are providing acceptable output. If the output is not acceptable, verify the proper magneto gap, and re-gap if necessary.
  - ii. Verify that the magnet that is in the flywheel is still magnetic, is not damaged, and/or has not been misplaced. Repair it if necessary.
  - iii. If the magneto coil is still not functioning properly, replace it.
- d. Inspect the spark plugs for damage and proper gap:
  - Remove and inspect spark plugs. If they are damaged or dirty, replace them.
  - Measure the spark plug gap. Re-gap if necessary.
18. Measure temperature of the air intake and temperature rise across the generator set.
  - Remove the blockage or prevent air recirculation as necessary.

## Code 37 - Invalid Set Configuration

**Logic:** Generator set control configuration does not meet any valid configuration.

**Possible Causes:**

- Generator set configuration
- Control

---

**Diagnosis & Repair:**

1. Check the last fault recorded.
  - If this fault has not been repaired, troubleshoot that fault.
2. Using the display, reset and save the generator set configuration. See the instructions in the "Generator Config" Screen section.
3. If the generator set configuration is correct and the fault will not clear, replace the control.

**Code 43 - Processor Fault**

**Logic:** RAM (programming variables) error during self-test

**Possible Causes:** Faulty program

**Diagnosis & Solution:**

1. Check the last fault recorded.
  - If this fault has not been repaired, troubleshoot that fault.
2. Replace the control as necessary.

**Code 45 - Speed Sense Fault**

**Logic:** While running, the quadrature frequency dropped to 0 Hz for 1 continuous second

**Possible Causes:**

- Loads
- Alternator windings
- Wire connections
- Open or corroded slip rings

**Diagnosis & Repair:**

1. Check the last fault recorded.
  - If this fault has not been repaired, troubleshoot that fault.
2. Inspect slip rings and clean them as required.
3. Disconnect the generator set control P1 connector.
4. Measure the quadrature winding resistance between pin sockets P1-2 and P1-3; compare that to the value in the table in the Alternator section.
  - a. If open or shorted, measure quadrature winding resistance at pins of AC-J 1 and 2 and compare to table value.
    - If not within range, replace the alternator.
  - b. If acceptable, check for continuity between P1-2 and AC-P 1, and also P1-3 and AC-P 2.
    - If open or shorted, repair or replace the harness.

5. Verify that the P1 pin socket is fully inserted and inspect the pin socket condition for corrosion and acceptable condition of contact wipers. To check contact wipers, use one of the devices below:
  - A mating pin connector
  - A pin gauge the same size as the mating control connector pin (0.045 in)
  - Any suitable device that will not damage the inside contact wipers of the pin socket
- If necessary:
  - Clean, repair or replace the pin socket.
  - Fully insert any partially inserted pin socket.
6. Inspect the condition of the P1 pin on the control board. If it is damaged or severely corroded, clean or repair if possible, or replace the control board.
7. When reconnecting the harness plug to the connector, ensure that the pair are fully seated next to each other.
8. Reconnect the P1 connector and test-run the generator set for fault occurrence.
9. Measure the AC current while running the generator set with loads.
  - Identify faulty or short cycling loads.
10. Measure the generator set load capability with load bank; de-rate for altitude and temperature if necessary.
11. Measure the generator set frequency and droop while running.

## Code 46 - Generator Set Overload

**Logic:** The total generator set load is above 105% of rated.

**Possible Causes:** Excessive load connected to the generator set

### Diagnosis & Repair:

1. Check the last fault recorded.
  - If this fault has not been repaired, troubleshoot that fault.
2. Measure the AC current and voltage while running the generator set with all connected loads.
  - a. Identify faulty or short cycling loads.
  - b. Reduce loads as necessary. (The Cummins load management kit can be used to automatically reduce connected loads.)

## Code 76 - Alternator Over Temp

**Logic:** The temperature at the alternator is too high. The high temperature switch opens between 197 - 209 °F (91.5 - 98.5 °C). An open condition on this circuit triggers the fault.

### Possible Causes:

- Wire connections

- Faulty temperature switch
- Faulty generator set or fan drive
- Cooling air flow not adequate

**Diagnosis & Solution:**

1. Check the last fault recorded.
    - If this fault has not been repaired, troubleshoot that fault.
  2. Verify the generator set air inlet and air outlet panels are not obstructed. Verify that there are no foreign objects within the enclosure that limit air flow.
  3. Disconnect the generator set control P1 connector.
  4. Verify that the P1 pin socket is fully inserted and inspect the pin socket condition for corrosion and acceptable condition of contact wipers. To check contact wipers, use one of the devices below:
    - A mating pin connector
    - A pin gauge the same size as the mating control connector pin (0.045 in)
    - Any suitable device that will not damage the inside contact wipers of the pin socket
- If necessary:
- Clean, repair or replace the pin socket.
  - Fully insert any partially inserted pin socket.
5. Inspect the condition of the P1 pin on the control board. If it is damaged or severely corroded, clean or repair if possible, or replace the control board.
  6. When reconnecting the harness plug to the connector, ensure that the pair are fully seated next to each other.
  7. Reconnect the P1 connector and test-run the generator set for fault occurrence.
  8. Measure the temperature sensor wiring (P1-33 to GND) for continuity to ground. Repair or replace as necessary. If the circuit is open, check the harness and temperature switch for open conditions; repair or replace as necessary.
  9. Visually inspect the generator set cooling fan for missing or damaged blades.
    - Replace the fan if damaged in any way.
    - The fan is connected to the rotor via a taper joint; verify that the fan is securely connected to the rotor shaft.
      - If the connection is loose, remove and inspect the tapers.
      - If a component is damaged, replace the component.



---

## 7.11 Remote Monitoring Communication Troubleshooting

### Generator Set Connection Problems

#### Possible Causes:

1. The generator set is not connected to the Internet.
2. There are router and/or firewall problems.
3. The Connect Cloud is unavailable.
4. There is a generator set control board problem.

#### Diagnosis and Repair:

1. The generator set is not connected to the Internet.
  - a. Verify the Internet connection status on the generator set local or remote display. This information is displayed on the Cloud Info screen in the MENU – About.
    - If the control is failing to connect to the Internet after multiple tries, power-cycle the control.
  - b. Check the generator set control board for the IP address and data transfer “heartbeat”.
    - i. Use the generator set’s local display or remote display to navigate through the menus until you find the IP address. Make sure that there is a valid IP address shown.
    - ii. Check the generator set control board for illuminated green and orange lights (also known as the “heartbeat”) near the Ethernet port. If the board is properly communicating with the network, the lights should flicker on and off irregularly.
  - c. Battery voltage is low.
    - Refer to the Starting Battery Runs Down or Low Battery Warning Is Active section.
  - d. The customer’s modem or router has no Internet connectivity.
    - i. Check the Internet connection indicator on the modem or router.
      - If the Internet connection indicator is not illuminated, reset the modem or router. Refer to the modem or router owner’s manual for the proper procedure.
    - ii. Access a web page using a computer connected via Ethernet cable to the same modem or router that the generator set is connected to.
    - iii. Contact the Internet Service Provider (ISP) for additional troubleshooting.
  - e. Check the Ethernet cable to the generator set.
    - i. Verify that the Ethernet cable type is Cat 5, Cat 5e, or Cat 6.

- ii. Verify that the Ethernet cable is fully seated in the generator set control.
  - iii. Verify that the cable is fully seated in the router or modem.
  - iv. Check the cable for breaks or damage; replace if necessary.
  - v. If a laptop is available for testing, unplug the Ethernet cable at the generator set and connect the laptop. Verify that the laptop has Internet access over the local network.
2. There are router and/or firewall problems.
    - Reset the firewall settings on the modem or router. Refer to the modem or router owner's manual for the proper procedure. Contact the Internet Service Provider for additional troubleshooting.
  3. The Connect Cloud is unavailable.
    - Verify availability by accessing the Connect Cloud from another device, and/or another browser.
  4. There is a generator set control board problem.
    - If there is still a problem after you have completed all other troubleshooting, it is possible the control board has a problem and must be replaced. However, it is very unlikely that the remote monitoring portion of the control board has a problem if all other generator set functions are operational.

## Mobile Device or Computer Connection Problem

### Possible Causes:

1. The Connect Cloud web page does not load because of an Internet connection problem.
2. The mobile device or computer has an Internet connection problem.
3. The customer's modem or router does not have Internet connectivity.

### Diagnosis and Repair:

1. The Connect Cloud Web page does not load because of an Internet connection problem.
  - a. Open your preferred browser and navigate to another web page to verify the Internet connection.
  - b. Reset the Internet settings or access the Connect Cloud from another browser.
2. The mobile device or computer has an Internet connection problem.
  - a. Make sure that at least one of the following conditions is true:
    - The mobile device or computer is connected via an Ethernet cable.
    - The mobile device or computer Wi-Fi is enabled and connected.
    - The mobile device or computer cellular data signal strength is acceptable.

- 
- b. If you are unable to resolve an Internet connection problem, contact the cellular data or Internet Service Provider.
  3. The customer's modem or router does not have Internet connectivity.
    - a. Check the Internet connection indicator on the modem or router.
      - If the Internet connection indicator is not illuminated, reset the modem or router. Refer to the modem or router owner's manual for the proper procedure.
    - b. Access a web page using a computer connected via Ethernet cable to the same modem or router that the generator set is connected to.
    - c. Contact the Internet Service Provider (ISP) for additional troubleshooting.

## **No Email Notifications Are Being Received**

### **Possible Causes:**

1. The incorrect email address was entered.
2. Emails are being filtered by a spam filter.
3. Connection problems exist between the generator set and the Connect Cloud.
4. The Connect Cloud is unavailable.
5. There is a generator set control board failure.

### **Diagnosis and Repair**

1. The incorrect email address was entered.
  - Verify the email address by using Preferences, Manage Users on the Connect Cloud.
2. Emails are being filtered by a spam filter.
  - a. Check your spam and junk folder for messages.
  - b. If you find emails from "noreply@powercommandcloud.com" in your junk/spam folder, add this address to your list of trusted senders, or select this sender as safe.
3. Connection problems exist between the generator set and the Connect Cloud.
  - Refer to the Generator Set Connection Problem section.
4. The Connect Cloud is unavailable.
  - Verify availability by accessing the Connect Cloud from another device and/or another browser.
5. There is a generator set control board problem.
  - If there is still a problem after you have completed all other troubleshooting, it is possible the control board has a problem and must be replaced. However, it is very unlikely that the remote monitoring portion of the control board has a problem if all other generator set functions are operational.

---

## Web Page Information Not Updating or Is Updating Slowly

### Possible Causes:

1. Data has not been refreshed.
2. Connection problems exist between the mobile device or computer and the Internet.
3. The user is not logged in.
4. The Internet connection is slow.
5. Connection problems exist between the generator set and the Connect Cloud.
6. The Connect Cloud is unavailable.

### Diagnosis and Repair:

1. Data has not been refreshed.
  - Refresh the web page or the mobile app by using the refresh function in the menu or by swiping down.
2. Connection problems exist between the mobile device or computer and the Internet.
  - Refer to the Mobile Device or Computer Connection Problem section.
3. The user is not logged in.
  - Make sure that you are logged in using the correct username and password.
4. The Internet connection is slow.
  - Verify that the Internet bandwidth of the network that the generator set is connected to has at least 1 mbps download speed. Use an Internet speed testing website on the same modem/router as the generator set to confirm connection speed.
5. Connection problems exist between the generator set and the Connect Cloud.
  - Refer to the Generator Set Connection Problems section.
6. The Connect Cloud is unavailable.
  - Verify availability by accessing the Connect Cloud from another device, and/or another browser.

## Generator Set Does Not Respond to Start and/or Stop Commands from the Web Page or Mobile App

### Possible Causes:

1. Remote Enable is not enabled at the local display.
2. Connection problems exist between the generator set and the Connect Cloud.
3. Connection problems exist between the mobile device or computer and the Connect Cloud.

4. The generator set is receiving a remote start command, but another failure has occurred preventing the generator set from starting.
5. The generator set is receiving a remote stop command, but another failure has occurred preventing the generator set from stopping.
6. The Connect Cloud is unavailable.

**Diagnosis and Repair:**

1. Remote Enable is not enabled at the local display.
  - Change the Remote Enable setting to Enabled on the local display.
2. Connection problems exist between the generator set and the Connect Cloud.
  - Refer to the Generator Set Connection Problems section.
3. Connection problems exist between the mobile device or computer and the Connect Cloud.
  - Refer to the Mobile Device or Computer Connection Problem section.
4. The generator set is receiving a remote start command, but another failure has occurred preventing the generator from starting.
  - a. Check the local or remote display, the mobile app, or the website for faults on the generator set.
  - b. Attempt to start the generator set from the local display.
5. The generator set is receiving a remote stop command, but another failure has occurred preventing the generator set from stopping.
  - a. Stop the generator set using the local display.
  - b. Stop the generator set using the local emergency stop.
6. The Connect Cloud is unavailable.
  - Verify availability by accessing the Connect Cloud from another device and/or another browser.

**Mobile App Push Notifications Do Not Appear****Possible Causes:**

1. Push notifications are not enabled in the Connect Cloud app.
2. Mobile device application permissions do not allow push notifications.

**Diagnosis and Repair:**

1. Push notifications are not enabled in the Connect Cloud app.
  - Enable push notifications in the Connect Cloud app settings.
2. Mobile device application permissions do not allow push notifications.
  - Change the mobile device settings on your phone or other mobile device to allow push notifications from the application.

---

## User Unable to Log In

### Possible Causes:

1. The Username or password is incorrect.
2. The Connect Cloud is unavailable.

### Diagnosis and Repair:

1. The Username or password is incorrect.
  - a. Make sure that you are using the correct username and password.
  - b. Make sure that the caps lock is not active.
  - c. Click on the “Can’t access your account?” link to recover the account.
2. The Connect Cloud is unavailable.
  - Verify availability by accessing the Connect Cloud from another device and/or another browser.

## Generator Set Starts or Stops Unexpectedly

### Possible Causes:

1. An accidental web page or mobile app start/stop command was received.

### Diagnosis and Repair:

1. An accidental web page or mobile app start/stop command was received.
  - a. The mobile app has the option to enable a PIN for any start/stop commands. Enable or disable the PIN in the mobile app settings.
  - b. The Connect Cloud website requires a confirmation for any start/stop commands.

## Webpage or Mobile App Does Not Respond

### Possible Causes:

1. Connection problems exist between the mobile device or computer and the Connect Cloud.
2. The web page or app has encountered an error.
3. The mobile device or computer has experienced an error.
4. The Connect Cloud is unavailable.

### Diagnosis and Repair:

1. Connection problems exist between the mobile device or computer and the Connect Cloud.
  - a. Refer to the Mobile Device or Computer Connection Problem section.
2. The web page or app has encountered an error.
  - a. Close the web browser and access the Connect Cloud from a new browser window.

- b. Close and end the mobile app session. Then restart the application.
3. The mobile device or computer has experienced an error.
  - a. Completely restart the mobile device or computer.
4. The Connect Cloud is unavailable.
  - a. Verify availability by accessing the Connect Cloud from another device and/or another browser.

This page is intentionally blank.



# Appendix A. Wiring Diagrams

---

## Table of Contents

Figure 58. Wiring Diagram (Sheet 1 of 6) .....	167
Figure 59. Wiring Diagram (Sheet 2 of 6) .....	168
Figure 60. Wiring Diagram (Sheet 3 of 6) .....	169
Figure 61. Wiring Diagram (Sheet 4 of 6) .....	170
Figure 62. Wiring Diagram (Sheet 5 of 6) .....	171
Figure 63. Wiring Diagram (Sheet 6 of 6) .....	172
Figure 64. Harness, Generator Set Electrical (Sheet 1 of 3) .....	173
Figure 65. Harness, Generator Set Electrical (Sheet 2 of 3) .....	174
Figure 66. Harness, Generator Set Electrical (Sheet 3 of 3) .....	175

## **A.0 Wiring Diagrams**

The drawings included in this section are representative. For current complete information, refer to the drawing package that was shipped with the unit.

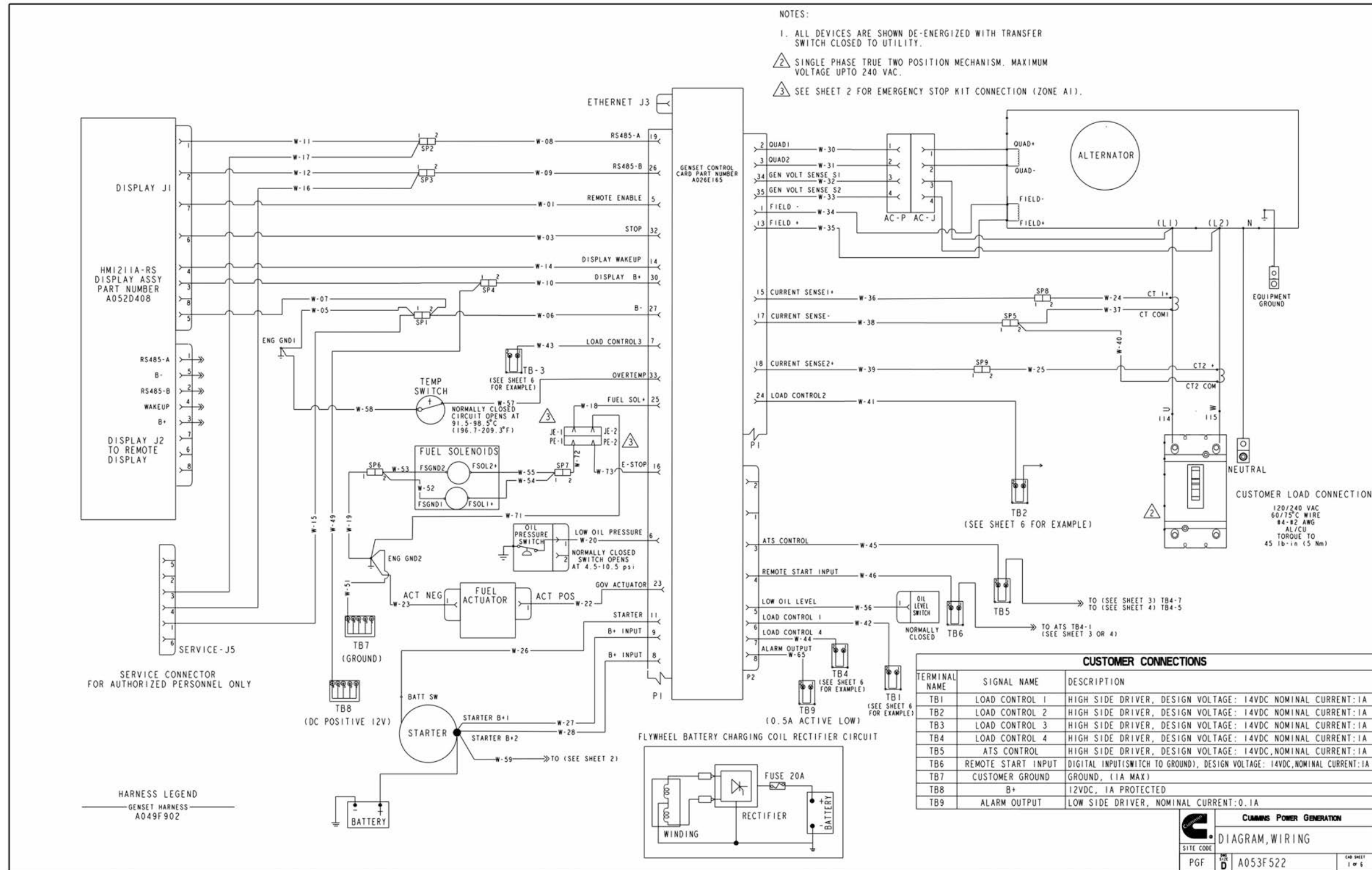


FIGURE 58. WIRING DIAGRAM (SHEET 1 OF 6)

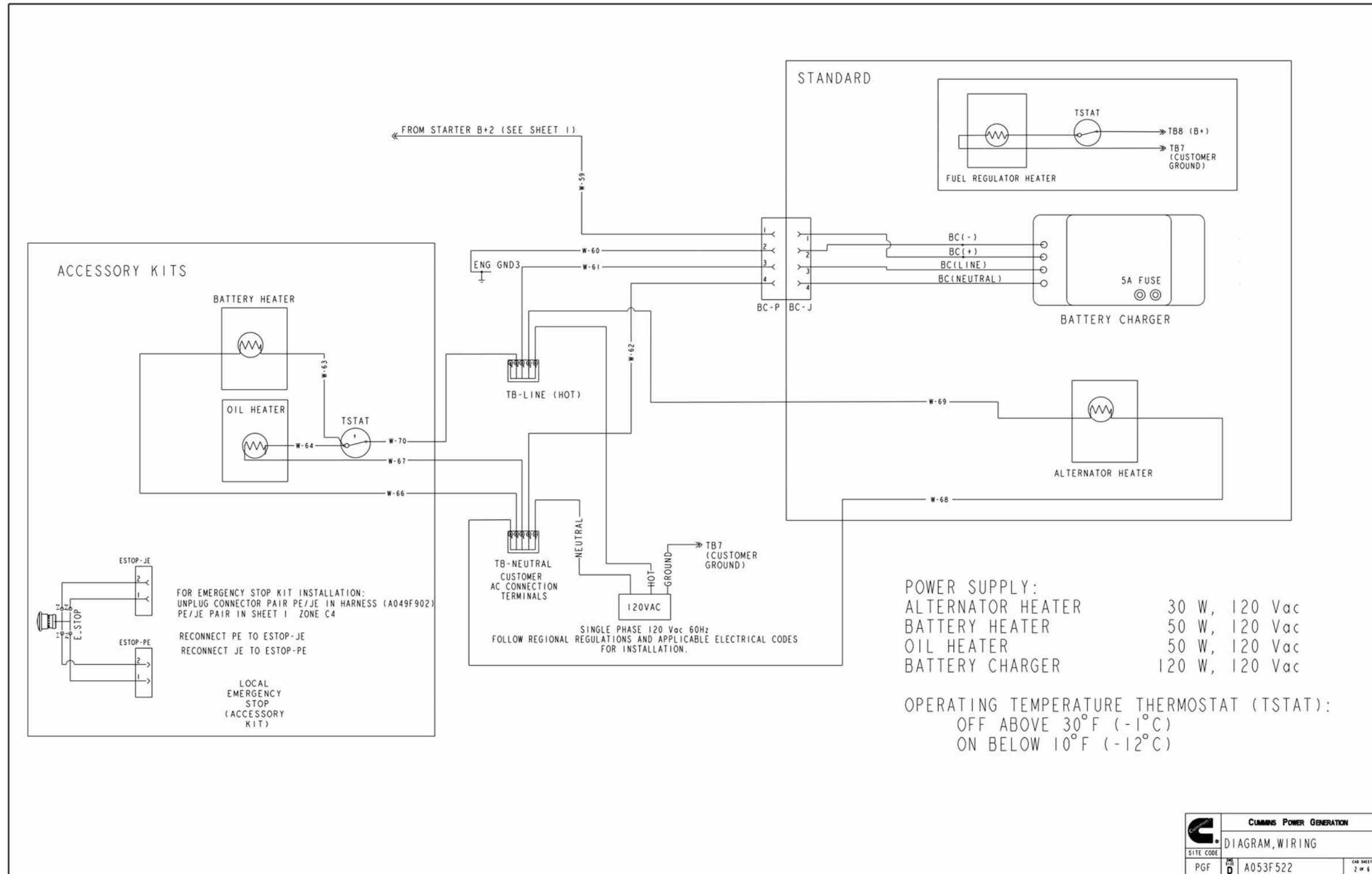


FIGURE 59. WIRING DIAGRAM (SHEET 2 OF 6)

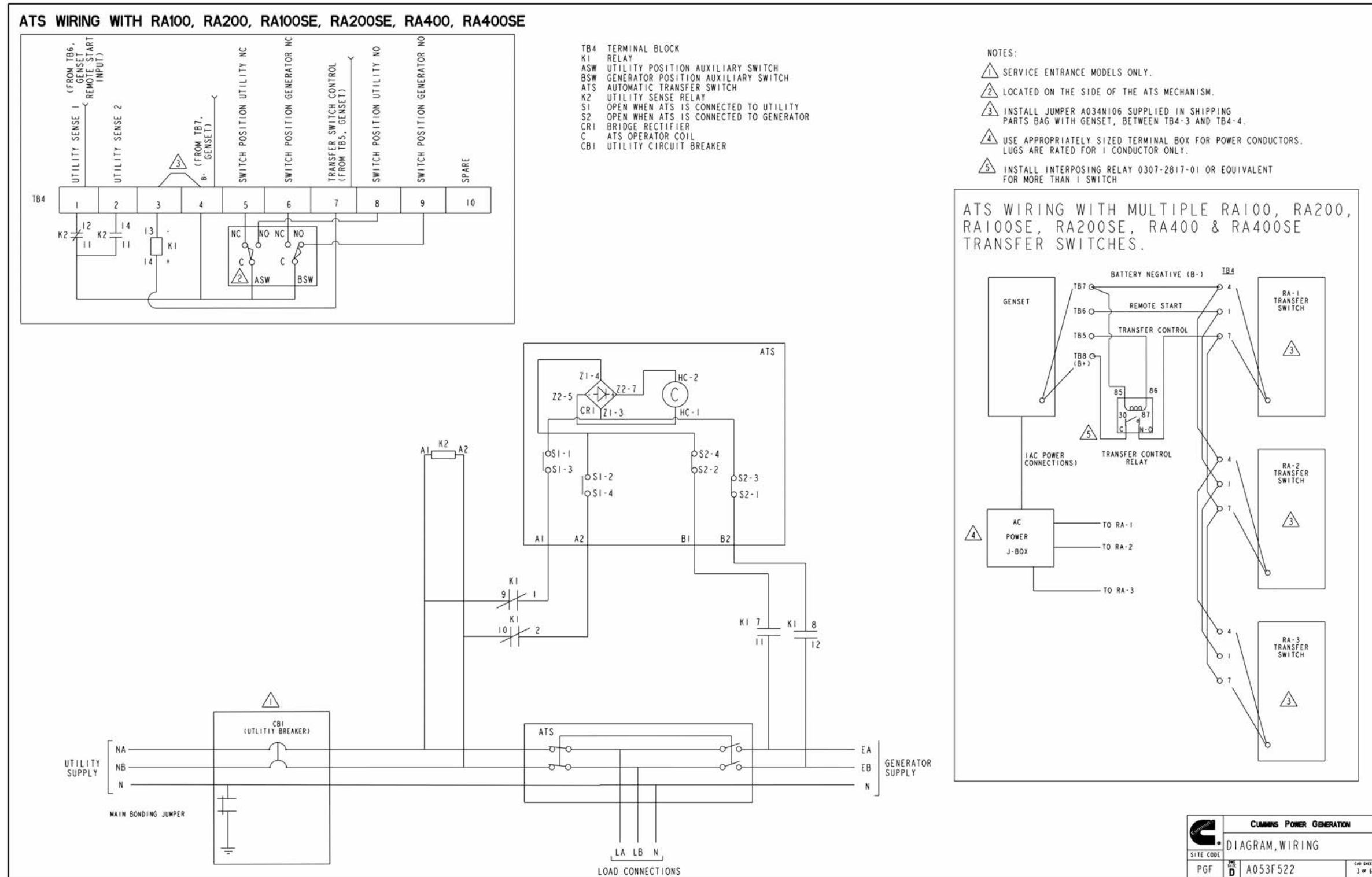


FIGURE 60. WIRING DIAGRAM (SHEET 3 OF 6)

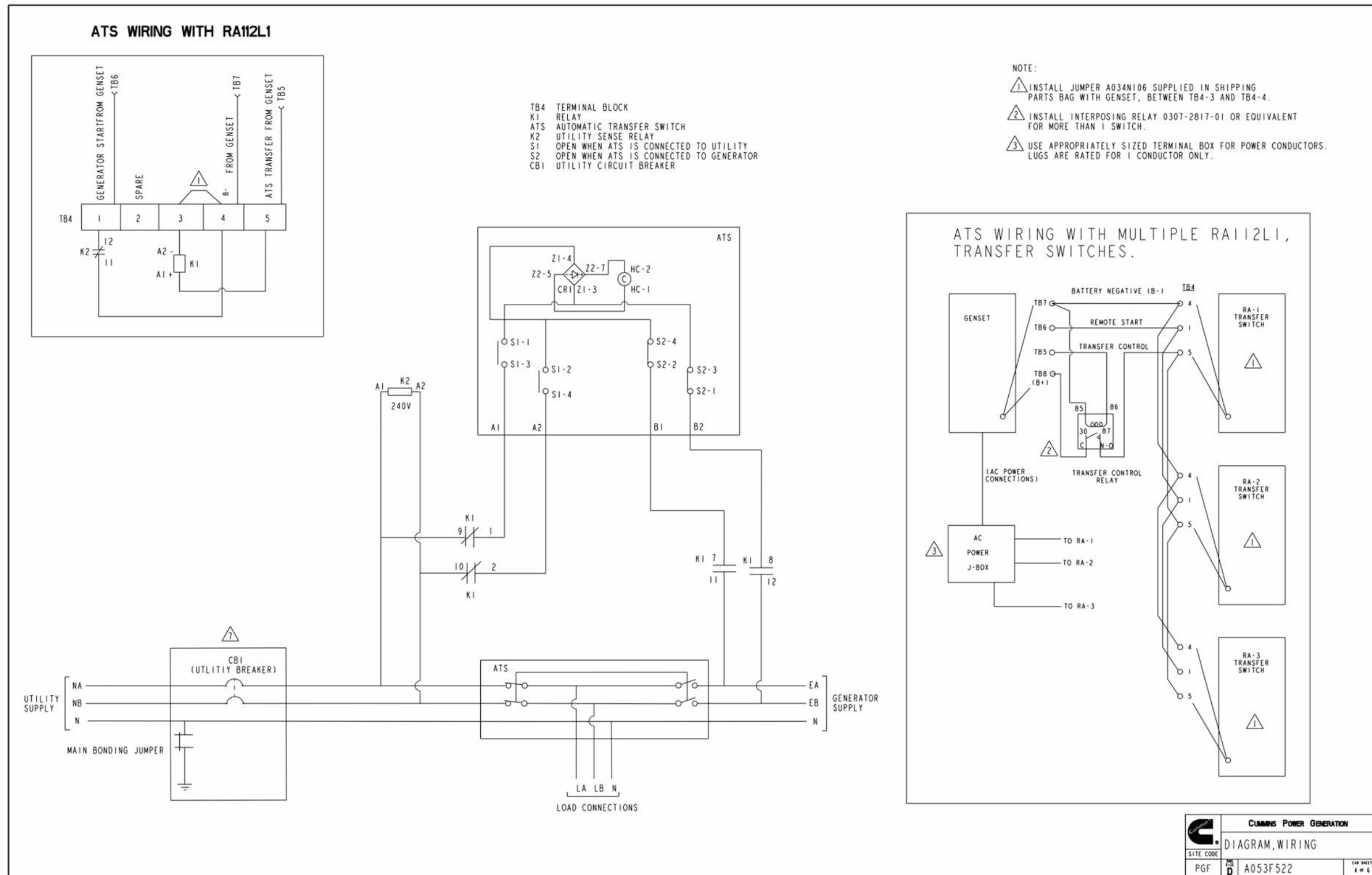


FIGURE 61. WIRING DIAGRAM (SHEET 4 OF 6)

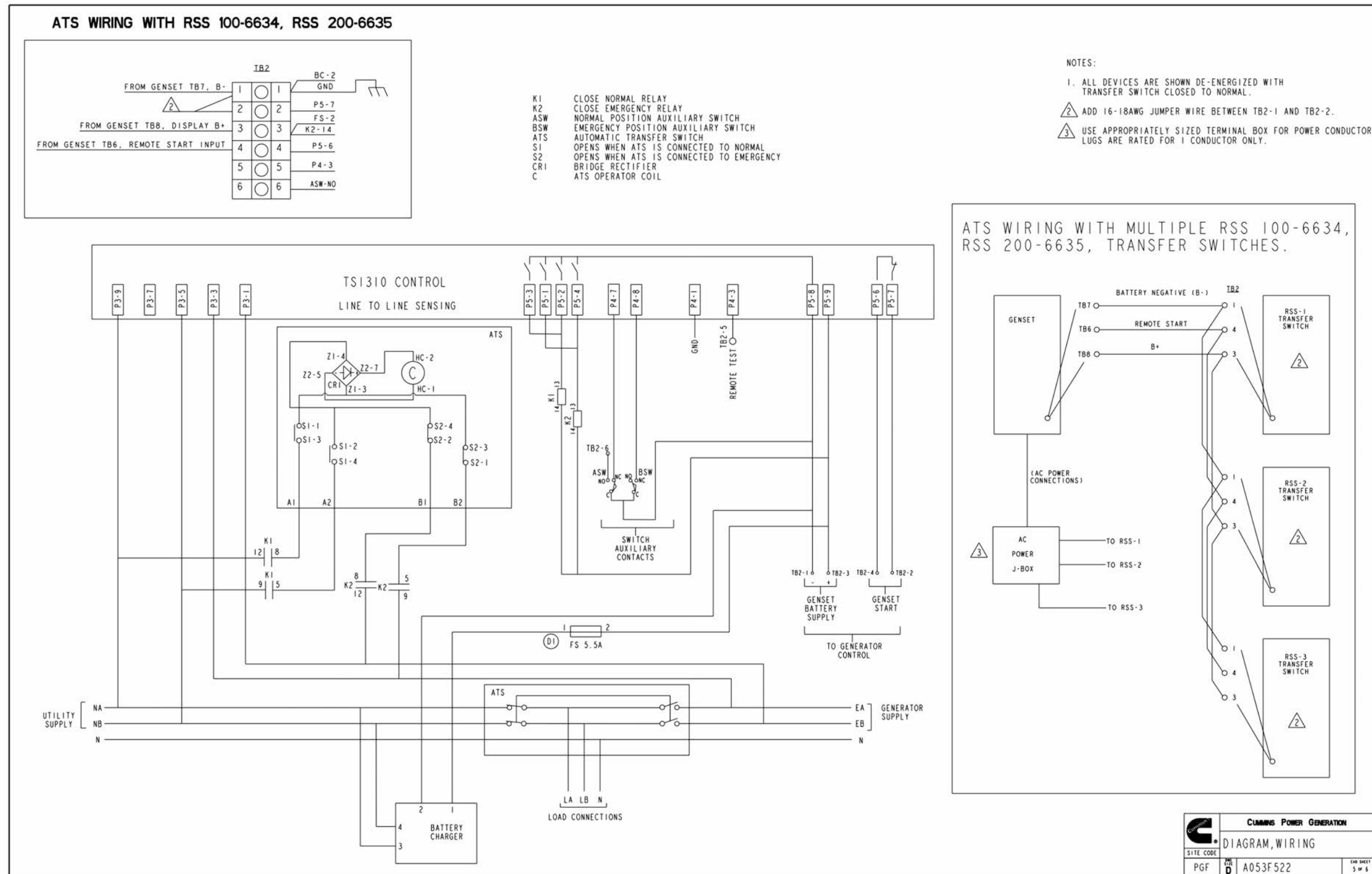


FIGURE 62. WIRING DIAGRAM (SHEET 5 OF 6)

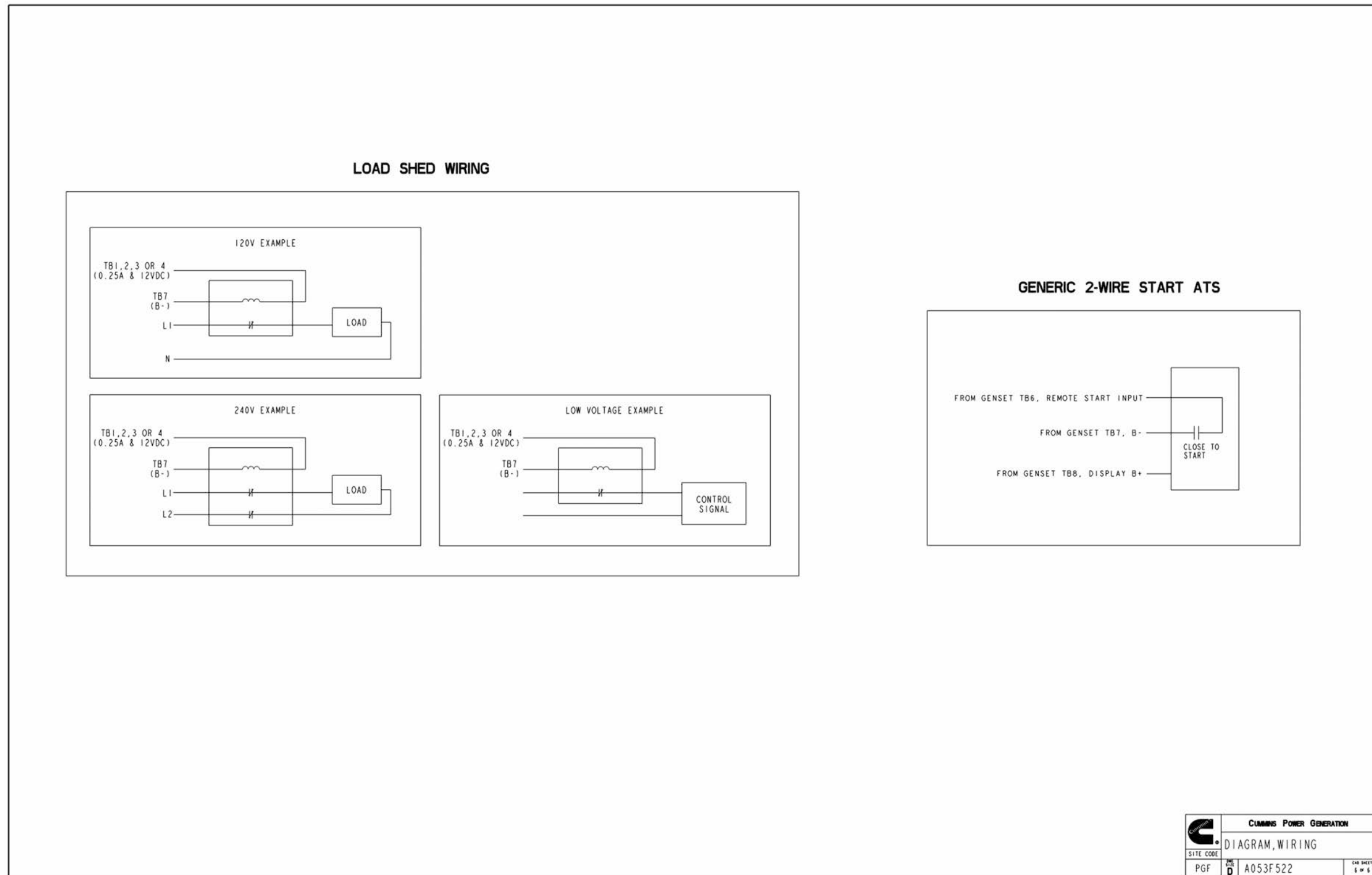


FIGURE 63. WIRING DIAGRAM (SHEET 6 OF 6)



LEAD NO	FROM			TO			WIRE GAUGE	WIRE COLOR	SPOOL_NAME
	STATION	CONNECTOR	PIN	STATION	CONNECTOR	PIN			
W-01	PI-5	0323-1819-01	0323-1614-01	DISPLAY PI-7	0323-2011	0323-2466	18	WHITE	A007P616
W-03	PI-32	0323-1819-01	0323-1614-01	DISPLAY PI-6	0323-2011	0323-2466	18	WHITE	A007P616
W-05	ENG GND1	0332-2964	NOT APPLY	SP1-1	0332-3638	NOT APPLY	16	WHITE	A007P614
W-06	PI-27	0323-1819-01	0323-1614-01	SP1-2	0332-3638	NOT APPLY	18	WHITE	A007P616
W-07	DISPLAY PI-5	0323-2011	0323-2466	SP1-2	0332-3638	NOT APPLY	18	WHITE	A007P616
W-08	SP2-2	0332-3638	NOT APPLY	PI-19	0323-1819-01	0323-1614-01	18	WHITE	A007P616
W-09	SP3-2	0332-3638	NOT APPLY	PI-26	0323-1819-01	0323-1614-01	18	WHITE	A007P616
W-10	SP4-2	0332-3638	NOT APPLY	PI-30	0323-1819-01	0323-1614-01	18	WHITE	A007P616
W-11	SP2-2	0332-3638	NOT APPLY	DISPLAY PI-1	0323-2011	0323-2466	18	WHITE	A007P616
W-12	DISPLAY PI-2	0323-2011	0323-2466	SP3-2	0332-3638	NOT APPLY	18	WHITE	A007P616
W-13	SP4-2	0332-3638	NOT APPLY	DISPLAY PI-3	0323-2011	0323-2466	18	WHITE	A007P616
W-14	DISPLAY PI-4	0323-2011	0323-2466	PI-14	0323-1819-01	0323-1614-01	18	WHITE	A007P616
W-15	SERVICE-J5-1	A044H291	0323-1491	SP1-2	0332-3638	NOT APPLY	18	WHITE	A007P616
W-16	SP3-2	0332-3638	NOT APPLY	SERVICE-J5-4	A044H291	0323-1491	18	WHITE	A007P616
W-17	SP2-2	0332-3638	NOT APPLY	SERVICE-J5-3	A044H291	0323-1491	18	WHITE	A007P616
W-18	PI-25	0323-1819-01	0323-1614-01	JE-1	0323-2237	A040M659	16	WHITE	A007P614
W-19	SP6-2	0332-3638	NOT APPLY	ENG GND2	0332-1048	NOT APPLY	16	WHITE	A007P614
W-20	OIL P-1	A043H382	A035D470	PI-6	0323-1819-01	0323-1614-01	18	WHITE	A007P616
W-22	ACT POS	0332-1992	NOT APPLY	PI-23	0323-1819-01	0323-1614-01	18	WHITE	A007P616
W-23	ACT NEG	0332-1992	NOT APPLY	ENG GND 2	0332-1048	NOT APPLY	18	WHITE	A007P616
W-24	SP8-2	0332-2947	NOT APPLY	CT1-1	A028X144	NOT APPLY	18	WHITE	A007P616
W-25	SP9-2	0332-2947	NOT APPLY	CT2-1	A028X144	NOT APPLY	18	WHITE	A007P616
W-26	PI-11	0323-1819-01	0323-1614-01	STARTER SW	0332-1993	NOT APPLY	16	WHITE	A007P614
W-27	STARTER B+1	0332-1194	NOT APPLY	PI-9	0323-1819-01	0323-1614-01	16	WHITE	A007P614
W-28	STARTER B+1	0332-1194	NOT APPLY	PI-8	0323-1819-01	0323-1614-01	16	WHITE	A007P614
W-30	PI-2	0323-1819-01	0323-1614-01	AC-P-1	A042N319	A043L492	18	WHITE	A007P616
W-31	PI-3	0323-1819-01	0323-1614-01	AC-P-2	A042N319	A043L492	18	WHITE	A007P616
W-32	PI-34	0323-1819-01	0323-1614-01	AC-P-4	A042N319	A043L492	18	WHITE	A007P616
W-33	PI-35	0323-1819-01	0323-1614-01	AC-P-3	A042N319	A043L492	18	WHITE	A007P616
W-34	FIELD NEG	0332-1992	NOT APPLY	PI-1	0323-1819-01	0323-1614-01	18	WHITE	A007P616
W-35	FIELD POS	0332-1992	NOT APPLY	PI-13	0323-1819-01	0323-1614-01	18	WHITE	A007P616
W-36	PI-15	0323-1819-01	0323-1614-01	SP8-1	0332-2947	NOT APPLY	18	WHITE	A007P616
W-37	SP5-2	0332-2947	NOT APPLY	CT COM1	A028X144	NOT APPLY	18	WHITE	A007P616
W-38	SP5-1	0332-2947	NOT APPLY	PI-17	0323-1819-01	0323-1614-01	18	WHITE	A007P616
W-39	PI-18	0323-1819-01	0323-1614-01	SP9-1	0332-2947	NOT APPLY	18	WHITE	A007P616
W-40	CT COM2	A028X144	NOT APPLY	SP5-2	0332-2947	NOT APPLY	18	WHITE	A007P616
W-41	PI-24	0323-1819-01	0323-1614-01	TB2-2	A034P713	0332-3491-01	18	WHITE	A007P616
W-42	P2-6	0323-2516	0323-1614-01	TB1-2	A034P713	0332-3491-01	18	WHITE	A007P616
W-43	PI-7	0323-1819-01	0323-1614-01	TB3-2	A034P713	0332-3491-01	18	WHITE	A007P616
W-44	TB4-2	A034P713	0332-3491-01	P2-7	0323-2516	0323-1614-01	18	WHITE	A007P616
W-45	P2-3	0323-2516	0323-1614-01	TB5-2	A034P713	0332-3491-01	18	WHITE	A007P616
W-46	P2-4	0323-2516	0323-1614-01	TB6-2	A034P713	0332-3491-01	18	WHITE	A007P616
W-49	SP4-2	0332-3638	NOT APPLY	TB8-5	A046D267	0332-3491-01	18	WHITE	A007P616
W-51	ENG GND2	0332-1048	NOT APPLY	TB7-5	A046D267	0332-3491-01	18	WHITE	A007P616
W-52	SP6-2	0332-3638	NOT APPLY	FSGND 1	0332-1992	NOT APPLY	18	WHITE	A007P616
W-53	SP6-2	0332-3638	NOT APPLY	FSGND 2	0332-1992	NOT APPLY	18	WHITE	A007P616
W-54	SP7-2	0332-2947	NOT APPLY	FSOL 1+	0332-1992	NOT APPLY	18	WHITE	A007P616
W-55	SP7-2	0332-2947	NOT APPLY	FSOL 2+	0332-1992	NOT APPLY	18	WHITE	A007P616
W-56	OIL LVL	A052Y617	NOT APPLY	P2-5	0323-2516	0323-1614-01	18	WHITE	A007P616
W-57	TEMP	0332-1992	NOT APPLY	PI-33	0323-1819-01	0323-1614-01	18	WHITE	A007P616
W-58	TGND	0332-1992	NOT APPLY	ENG GND 1	0332-2964	NOT APPLY	18	WHITE	A007P616
W-59	BC-P-1	A042N319	A043L492	STARTER B+2	0332-1194	NOT APPLY	16	WHITE	A007P614
W-60	BC-P-2	A042N319	A043L492	ENG GND 3	0332-2964	NOT APPLY	16	WHITE	A007P614
W-61	BC-P-3	A042N319	A043L492	TB-LINE-2	A046D267	0332-3491-01	16	WHITE	A007P614
W-62	BC-P-4	A042N319	A043L492	TB-NEUTRAL-2	A046D267	0332-3491-01	16	WHITE	A007P614
W-63	BATT HTR -L	0332-1993	NOT APPLY	TSTAT-1	0332-1995	NOT APPLY	16	WHITE	A007P614
W-64	OIL HTR -L	0332-1993	NOT APPLY	TSTAT-1	0332-1995	NOT APPLY	16	WHITE	A007P614
W-65	P2-8	0323-2516	0323-1614-01	TB9-2	A034P713	0332-3491-01	18	WHITE	A007P616
W-66	BATT HTR -N	0332-1993	NOT APPLY	TB-NEUTRAL-3	A046D267	0332-3491-01	16	WHITE	A007P614
W-67	OIL HTR -N	0332-1993	NOT APPLY	TB-NEUTRAL-4	A046D267	0332-3491-01	16	WHITE	A007P614
W-68	ALT HTR -N	0332-1993	NOT APPLY	TB-NEUTRAL-5	A046D267	0332-3491-01	16	WHITE	A007P614
W-69	ALT HTR -L	0332-1993	NOT APPLY	TB-LINE-5	A046D267	0332-3491-01	16	WHITE	A007P614
W-70	TSTAT-2	0332-1993	NOT APPLY	TB-LINE-3	A046D267	0332-3491-01	16	WHITE	A007P614
W-71	ENG GND2	0332-1048	NOT APPLY	JE-2	0323-2237	A040M659	16	WHITE	A007P614
W-72	PE-1	0323-2098	0323-2332	SP7-1	0332-2947	NOT APPLY	16	WHITE	A007P614
W-73	PE-2	0323-2098	0323-2332	PI-16	0323-1819-01	0323-1614-01	16	WHITE	A007P614

NOTES:

- TOLERANCES: UP TO 500 +15/-5  
500 TO 1000 +30/-10  
1000 TO LONGER +40/-20
- ALL LEADS/WIRES SHALL BE MARKED AT MAXIMUM OF 76 mm BEHIND THE CONNECTOR WITH BOTH STATION NUMBERS LISTED IN THE "FROM-TO" TABULATION. MARKING SHALL BE PERMANENT AND LEGIBLE. WIRE MARKINGS NEED TO HAVE FULL VISUAL ACCESS. END MARKINGS ARE NOT TO BE VISUALLY OBTURED AND MUST BE FULLY DISPLAYED. TO/FROM DESIGNATIONS ARE NOT TO BE FRAGMENTED. DESIGNATOR SHALL APPEAR IN FULL TEXT AND NOT IN BROKEN SEGMENTS.
- USE CABLE TIES (0332-3388) AS REQUIRED TO SECURE WIRES.
- HARNESS MUST BE PROCURED FROM A SUPPLIER QUALIFIED AS A UL RECOGNIZED HARNESS MANUFACTURER CATEGORY (ZPFW2). PACKAGING OF PARTS TO BE MARKED IN ACCORDANCE WITH REQUIREMENTS SPECIFIED BY SUPPLIERS UL PROGRAM.
- STAGGER AND COVER ALL UNINSULATED FASTONS, SPLICES, RING TERMINALS & RESISTORS WITH HEAT SHRINK (0898-1337-03).
- IF THE VALUE OF 0 (ZERO) IS USED IN THE BILL OF MATERIAL, THE QUANTITY OF THE AFFECTED ITEMS SHALL BE DERIVED FROM THE DRAWING REQUIREMENTS.
- USE TESA 51026 CLOTH WIRE TAPE OR EQUIVALENT CLOTH TAPE TO COVER THE HARNESS.
- ATTACH A MASTER HARNESS LABEL WITH THE FOLLOWING INFORMATION: CUMMINS PART NUMBER, CUMMINS PART REVISION LEVEL, MANUFACTURER'S NAME, MANUFACTURER'S LOCATION, AND MANUFACTURER'S DATE OF MANUFACTURE IN THE FORMAT OF MONTH, DATE, LAST 2 YEAR DIGITS. LABEL MUST BE MADE FROM UL RECOGNIZED VINYL SELF LAMINATION LABEL SYSTEM.
- TWISTED WIRE PAIRS SHOULD HAVE MINIMUM OF 5 TWIST PER FOOT.
- COMPONENTS CT1 AND CT2 ARE PART OF ASSEMBLY A028X144. ADJUST LEAD LENGTHS AS REQUIRED. LABEL AS "CT1" AND "CT2".
- INK FOR HARNESS MARKING, MUST RESIST ERASER ABRASION TEST, ANTIFREEZE, MOTOR OIL, TRANSMISSION FLUID, GASOLINE, DIESEL FUEL & BRAKE FLUID.
- MANUFACTURE TO IPC/WHMA-A-620 WORKMANSHIP STANDARD.
- POINT TO POINT CONTINUITY TEST MUST BE PERFORMED ON THIS HARNESS ASSEMBLY.
- PLACE INDIVIDUAL LABEL WITH FOLLOWING DETAIL  
TB1 : "TB1-LOAD CONTROL1", TB2 : "TB2-LOAD CONTROL2", TB3 : "TB3-LOAD CONTROL3", TB4 : "TB4-LOAD CONTROL4", TB5 : "TB5-ATS TRANSFER", TB6 : "TB6-REMOTE START", TB7 : "TB7-GROUND", TB8 : "TB8-FUSED B+ (IA)", TB9 : "TB9-ALARM OUTPUT", TB LINE : "LINE" & TB NEUTRAL : "NEUTRAL".
- COIL UP & TIE WRAP THE BRANCH TO THE MAIN BRANCH TO ALLOW IT TO BE REPOSITIONED DURING GENSET INSTALLATION.
- ATTACH A LABEL WITH UL MARK (UL SYMBOL AND OTHER UL REQUIRED INFORMATION) IN ACCORDANCE WITH REQUIREMENTS SPECIFIED BY THE SUPPLIER'S UL PROGRAM.
- (NOTE REMOVED).
- NO LOOP OR RADIUS REQUIRED, THIS IS JUST A DRAWING REPRESENTATION.
- PLUG CONNECTOR "PE" INTO CONNECTOR "JE".

TWISTED WIRE 


		CUMMINS POWER GENERATION	
		HARNESS, GENSET	
SITE CODE	PGF	REV D	A049F902
SHEET 1 OF 3	REV 11		

FIGURE 64. HARNESS, GENERATOR SET ELECTRICAL (SHEET 1 OF 3)

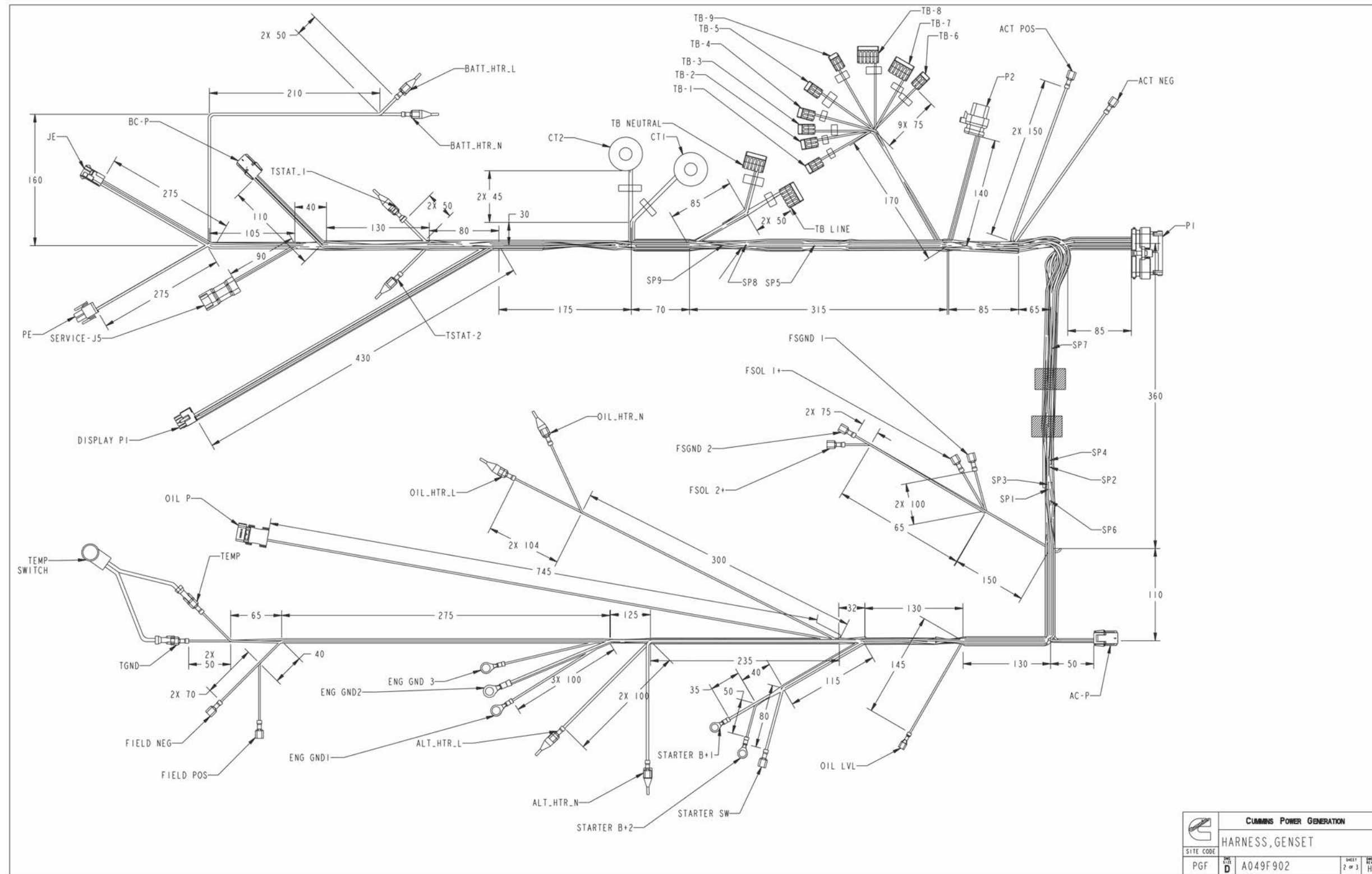


FIGURE 65. HARNESS, GENERATOR SET ELECTRICAL (SHEET 2 OF 3)

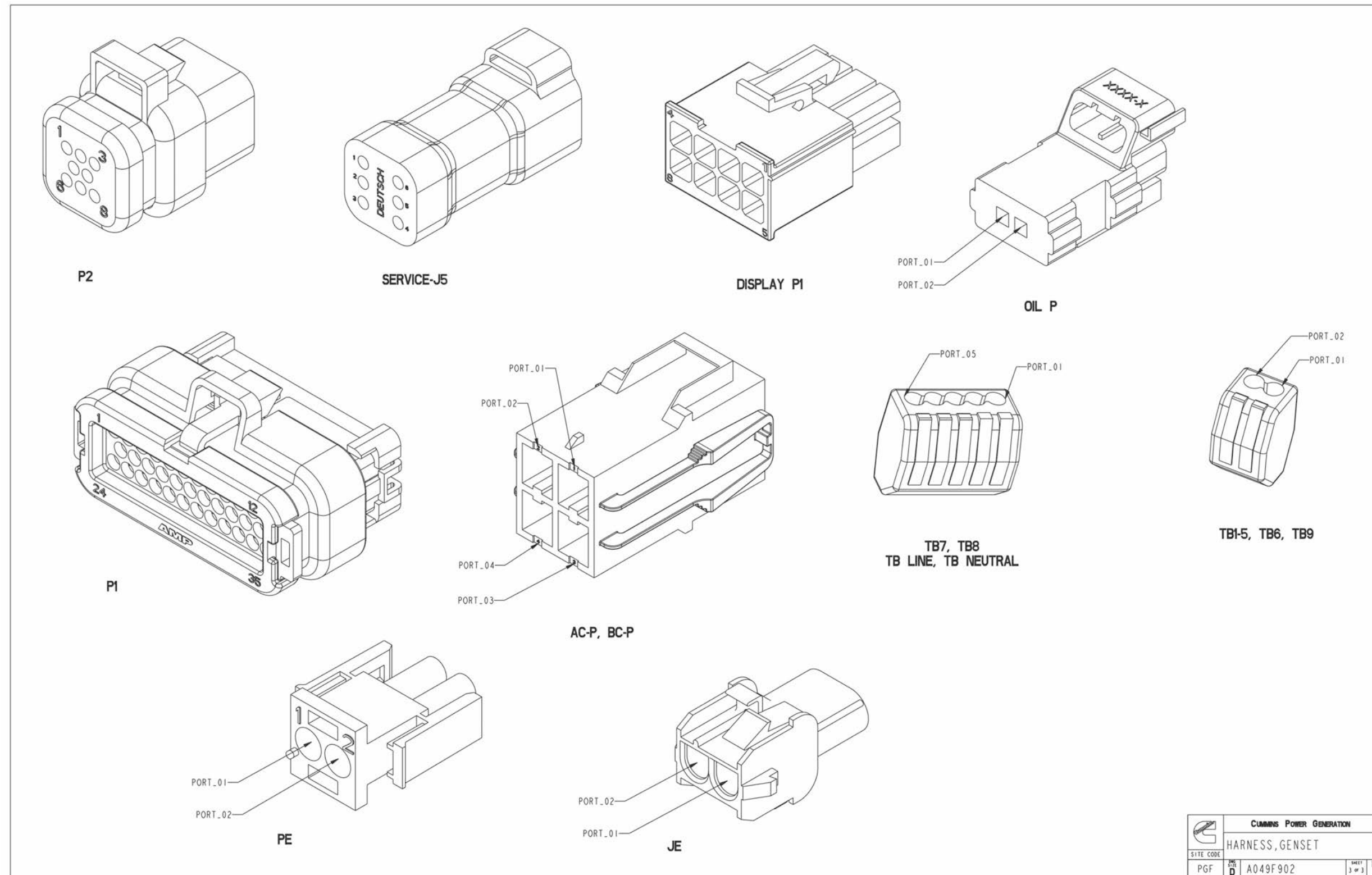


FIGURE 66. HARNESS, GENERATOR SET ELECTRICAL (SHEET 3 OF 3)

This page is intentionally blank.



[power.cummins.com](http://power.cummins.com)

Copyright © 2017 Cummins Inc. All rights reserved.

Cummins, the "C" logo, PowerCommand, AmpSentry, and InPower are trademarks of Cummins Inc.

Other company, product, or service names may be trademarks or service marks of others.

Specifications are subject to change without notice.

