

Assembly Instructions

898 12 Gun Slanted Base Cabinet

Components List:

Upper Cabinet

- R. Top Panel1pc
- A. Upper Barrel Rest.....1pc
- B. Upper Back Panel.....1pc
- C. Upper Left Side Panel.....1pc
- D. Upper Right Side Panel1pc
- E. Upper Door Frame.....1pc
- F. Drawer Top Panel.....1pc
- G. Lower Barrel Rest.....1pc

Upper Cabinet

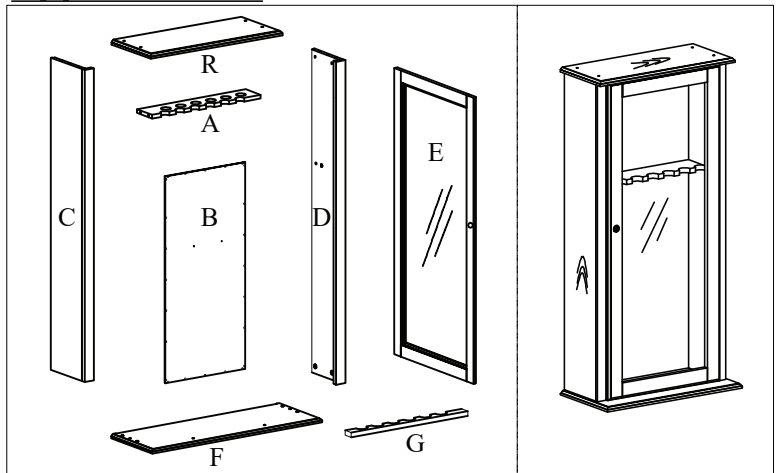

Lower Cabinet

- H. Bottom Door Frame1pc
- I. Bottom Back Panel1pc
- J. Bottom Front Rail 1pc
- K. Bottom Frame1pc
- L. Bottom Left Side Panel1pc
- M. Bottom Right Side Panel1pc
- N. Bottom Upper Front Rail.....1pc
- O. Bottom Shelf.1pc
- P. Bottom Middle Front Rail1pc
- Q. Middle Slanted Door Frame.....1pc

Lower Cabinet

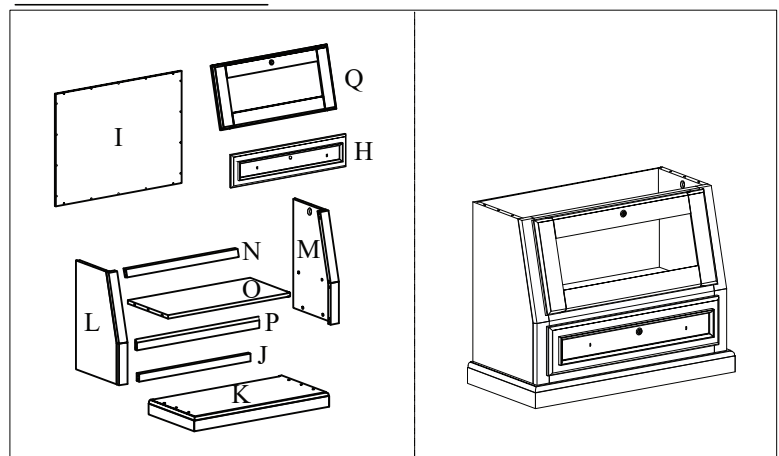

Hardware List:

- 1. "L"Wrench1pc
- 2. Metal Bullet.....10pcs
- 3. Machine Screw.....8pcs
- 4. Round Head Wood Screw38pcs
- 5. Flat Head Hinge Screw32pcs
- 6. Dowel.....34pcs
- 7. Door Spacer Black.....1pc
- 8. Door Knob2pcs
- 9. Knob Screw.....2pcs
- 10. Keys.....3pcs
- 11. Hinges7pcs
- 12. Levelers.....4pcs
- 13. Tipping Restraint.....1pc
- 14. Threaded pin.....2pcs
- 15. Acorn Nut.....2pcs
- 16. Wrench.....1pc
- 17. Door support.....1pc

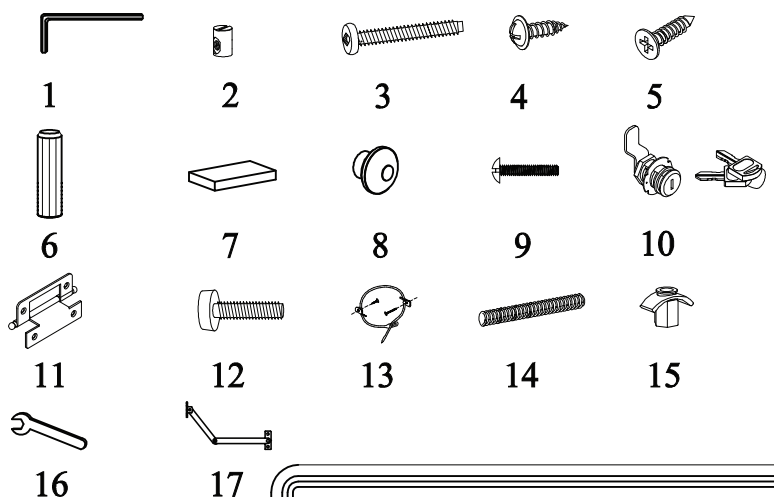

Post Office Box 111 - Webb City, Missouri 64870 - 0111

Toll Free - 888 - 673 - 9080

Fax - 417 - 673 - 9081

To order replacement parts online please visit:

www.AmericanFurnitureClassics.com

or E - mail :

service@americanfurnitureclassics.com

Assembly Instructions: 898 12 Gun Slanted Base Cabinet

Unpack carton on a clean, smooth surface and inventory parts.

Important: Always Insert Metal Bullets so that the X in the end of the Bullet faces out of the holes and that the Threaded Hole is turned vertically for alignment with Machine Screws.

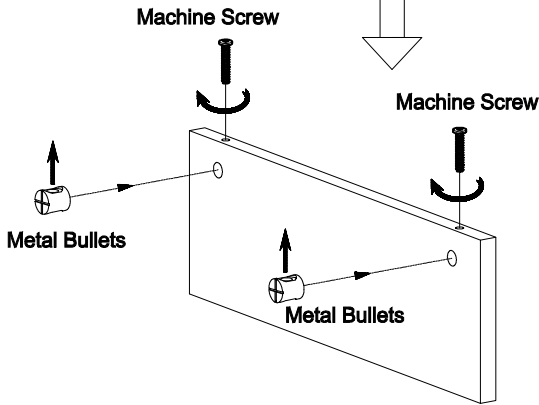

Step 1

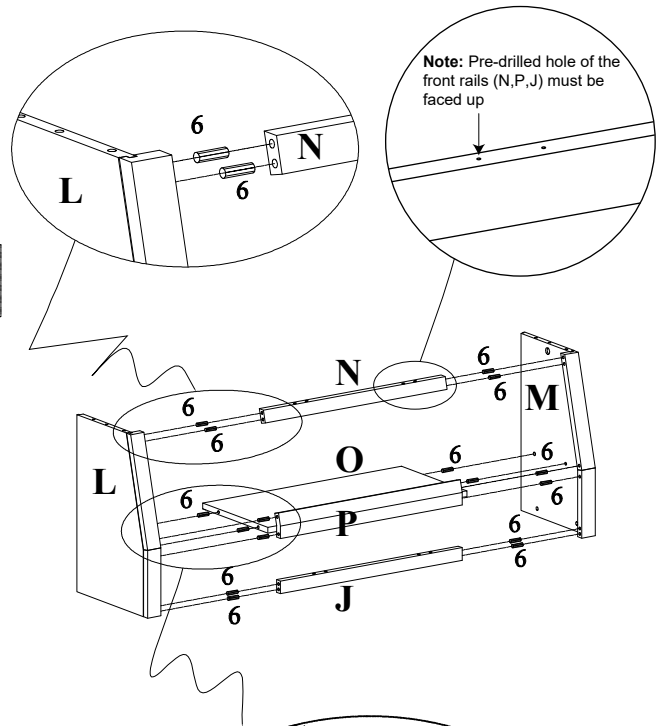

Step 1:

* Attach Bottom Upper Front Rail (N) to the Bottom Left & Right Side Panel (L & M) by inserting Dowel (6).

* Attach Bottom Shelf (O), Bottom Middle Front Rail (P) and Bottom Front Rail (K) to the Bottom Left & Right Side Panel (L & M) by inserting the Dowel (6).

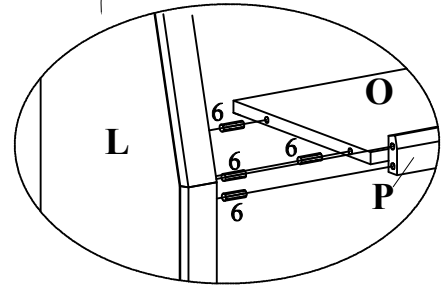

Step 2:

Insert the Dowel (6) into the holes in the Bottom Frame (K). Insert the Machine Screw (3) through the bottom of the Bottom Frame (K) and into the Metal Bullet (2) inserted into the Bottom Side Panel (L & M). Tighten the Machine Screw (3) using the "L" Wrench (1).

Step 2

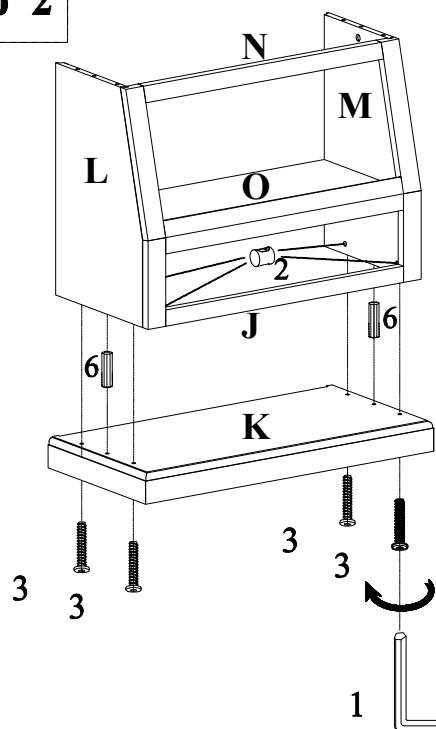

Assembly Instructions: 898 12 Gun Slanted Base Cabinet

Step 3:

Attach Upper Barrel Rest (A) to Upper Left Side Panel and Right Side Panel (C & D) by inserting Dowel (6) into the holes.

Step 3

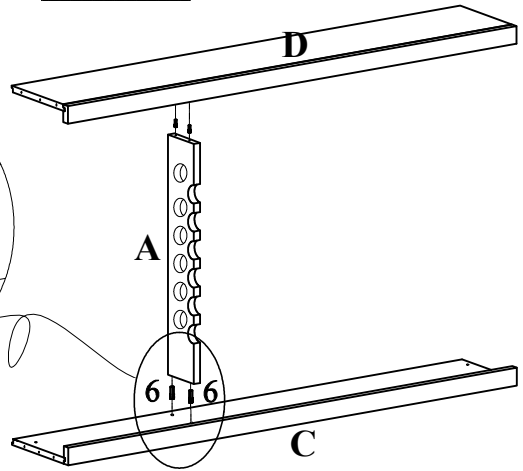

Step 4:

* Insert the Dowel (6) into the holes on the bottom side of Top Panel (R) and into the Upper Side Panels (C & D). Insert the Machine Screw (3) through the Top Panel (R) and into the Metal Bullet (2) inserted into the Upper Side Panels (C & D). Tighten the Machine Screw (3) using "L" Wrench (1).

* Insert the Dowel (6) into the holes on the top of Drawer Top Panel (F) and into the Upper Side Panels (C & D). Insert the Threaded Pin (14) through the bottom of Drawer Top Panel (F) and into the Metal Bullet (2) inserted into the Upper Side Panels (C & D). Tighten the Threaded Pin (14) by hand until it stops. **DO NOT OVER TIGHTEN!**

* Attach the Lower Barrel Rest (G) to the Drawer Top Panel (F) by inserting Dowel (6).

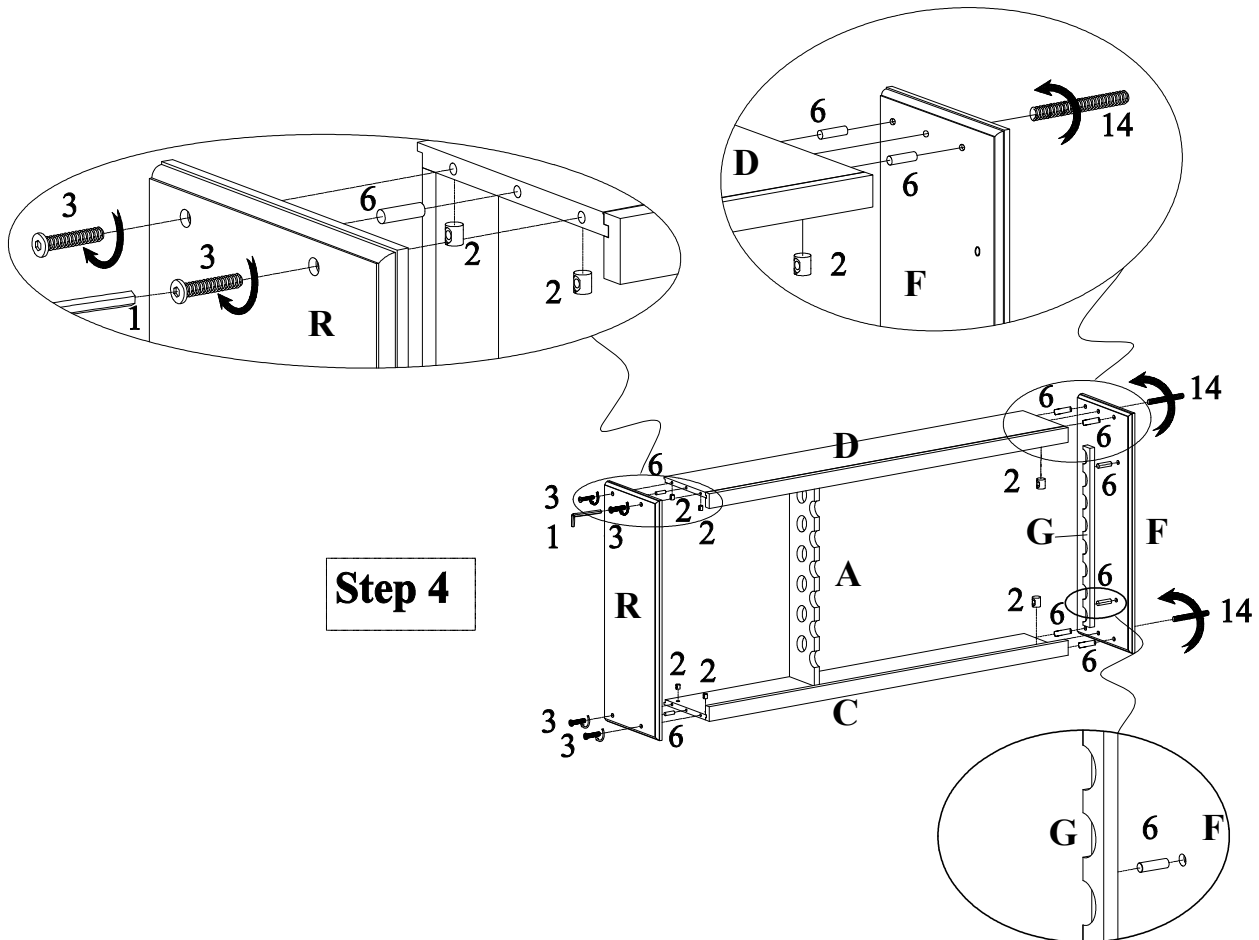

Step 4

Assembly Instructions: 898 12 Gun Slanted Base Cabinet

Step 5:

Lay both the Upper and Lower Cabinets on their back on the floor. Slide the Upper and Lower Cabinets together making sure that the Dowel (6) and the Threaded Pin (14) align properly with the holes in the Lower Cabinet Side Panels. Insert Acorn Nut (15) into large holes on the inside of the Lower Cabinet Sides (L & M). Screw onto the Threaded Pin (14) by hand then tighten fully by using Wrench (16).

Step 5

Step 6:

Align the holes on the hinges (11) with the pre-drilled holes on the Upper Right Side Panel (E), on the Bottom Middle Front Rail (P) and on the Bottom Front Rail (J). Insert Flat Head Hinge Screw (5) into the holes on the hinges (11) and tighten into the Upper Right Side Panel (D), Bottom Middle Front Rail (P) and Bottom Front Rail (J). Using Levelers (12) on the back side of Bottom Frame (K) if needed.

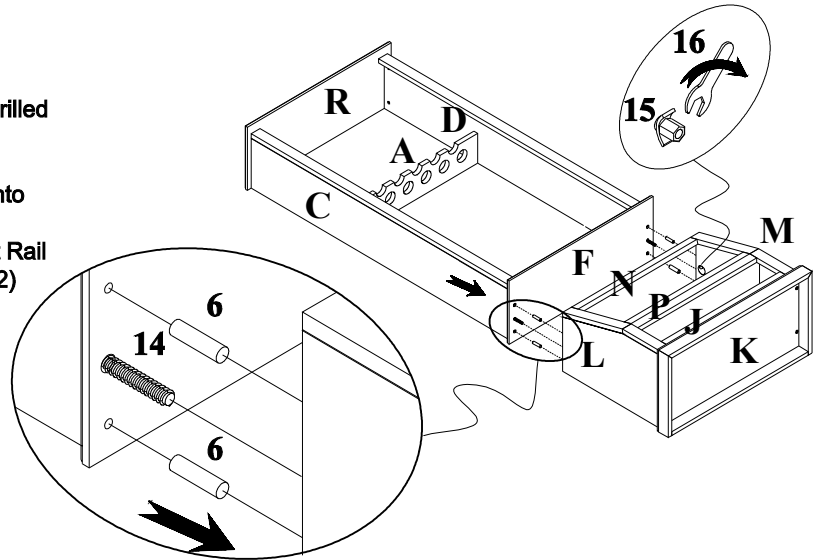

Step 6

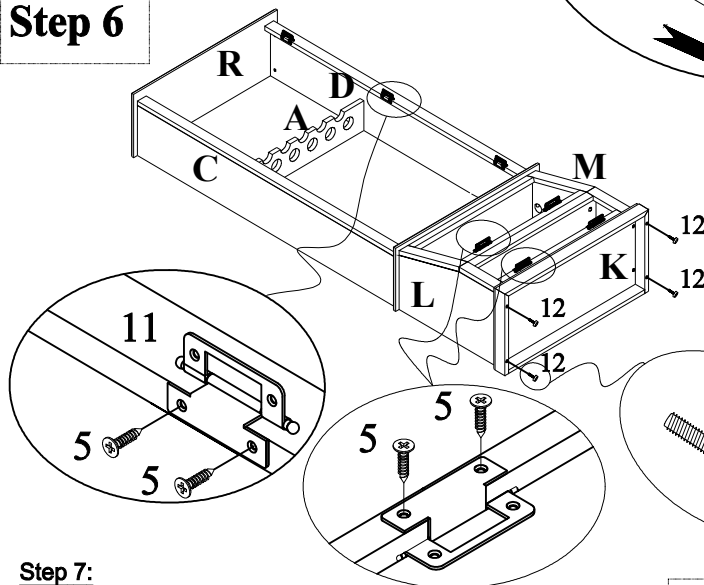

Step 7:

Lay Upper Door Panel (E) on top upper cabinet open position as shown. Place the Door Spacer Block (7) in between the Top Panel (R) and the Upper Door Panel (E) for correct spacing. Move Door Panel (E) toward the Top Panel (R) until it contacts the Door Spacers Block (7). Insert Flat Head Hinge Screw (5) through the holes of the Pre-attached hinge, and tighten into the Door Panel (E). Take off the Door Spacer Block (7).

Step 7

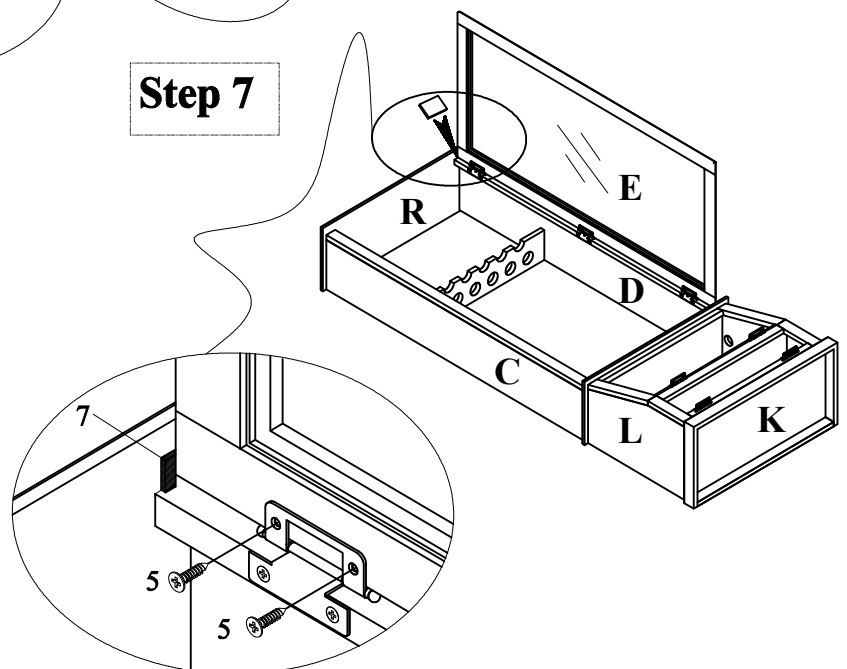

Assembly Instructions: 898 12 Gun Slanted Base Cabinet

Step 8:

* Lay Bottom Door Frame (H) align with Bottom Front Rail (J). Insert Flat Head Hinge Screw(5) through the holes of the pre-attached hinge and tighten into the Bottom Front Rail (J). Same way to secure the Middle slanted Door Frame (Q) to attach with Bottom Middle Front Rail (P).

* Align the holes on the Door Support(17) with the pre-drilled holes on the Bottom Right Side Panel(M). Insert Flat Head Hinges Screw(5) into the holes on the Door Support(17) and tighten into Bottom Right Side Panel (M). Same Way to secure the Door Support(17) to attach on the Middle Slanted Door Frame (Q).

Step 9:

Attach Upper Back Panel (B) and Bottom Back Panel (I) to the back of the assembled Upper Cabinet and Lower Cabinets using Round Head Wood Screws (4). Tighten with Philips Head Screwdriver (Not Provided).

Step 10:

Attach Knob (8) onto the outside of Bottom Door Frame (H) using Knob Screw (9). Tighten with Philips Head Screwdriver (Not Provided).

Step 9

Step 10

Step 8

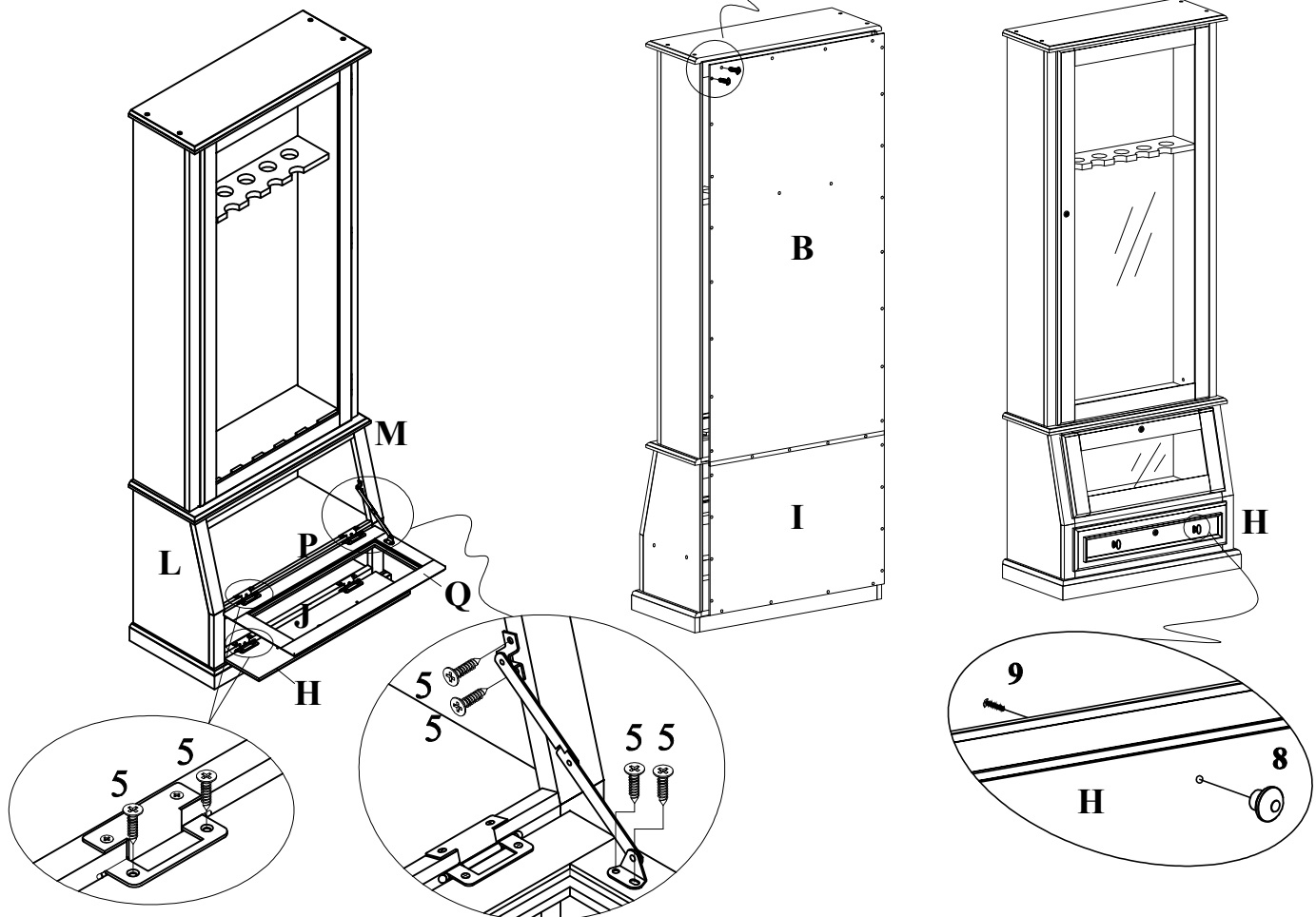

Assembly is now complete.

For extra safety we suggest you install the "Furniture Tipping Restraint" Provided in the separate hardware bag.

Assembly Instructions

Install the lock of the door

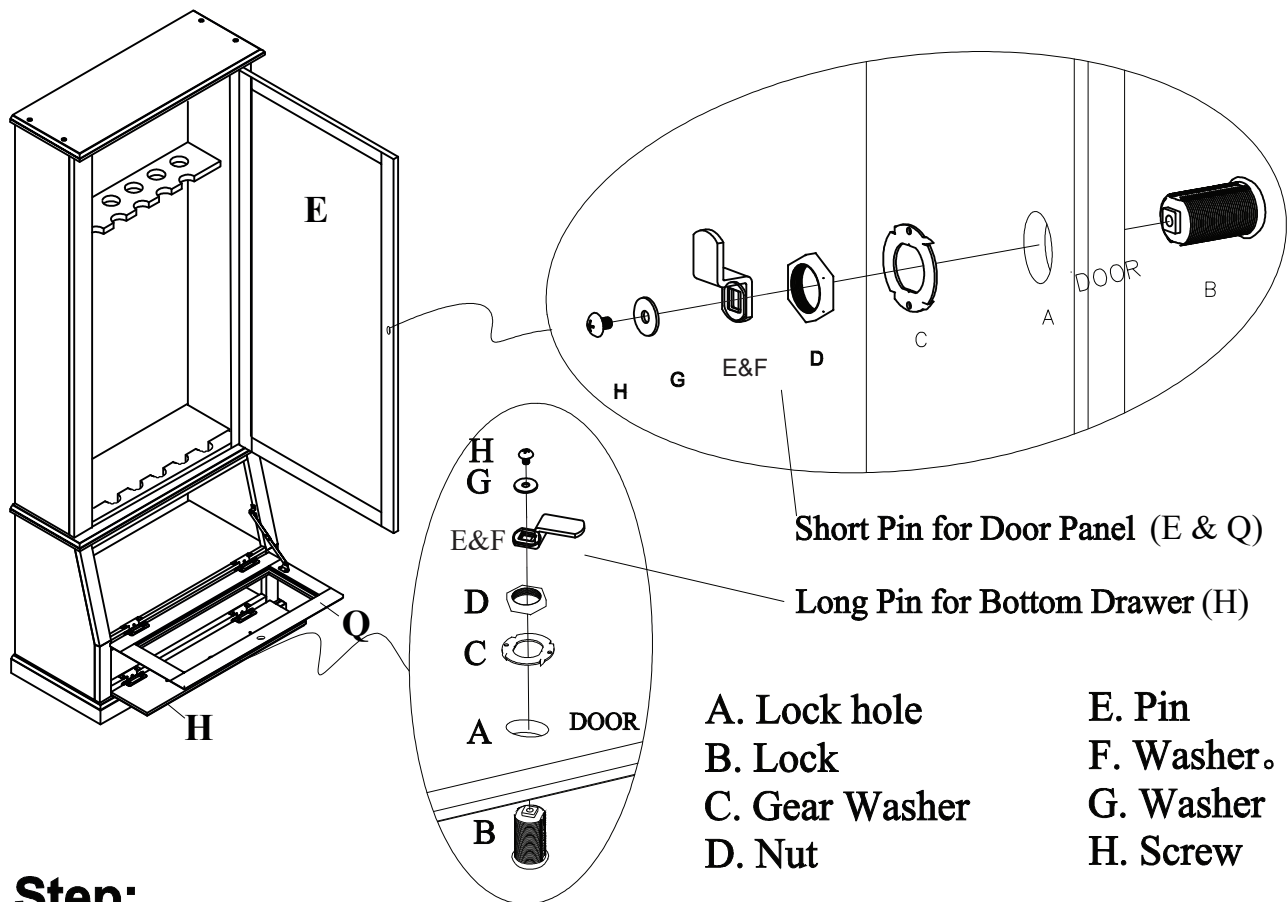

Step:

1. Insert Lock (B) into the Lock Hole(A).
2. Put Gear Washer (C) on the Lock (B).
3. Screw Nut (D) on Lock (B).
4. Place Pin (E) and washer (F) onto lock Barrel (B), Make sure the rectangular hole on Pin(E) & Washer (F) and on Lock Barrel (B) are aligned properly.
5. Insert washer(G) and screw (H) into the end of Lock Barrel(B)
6. Tighten or loosen Screw (H) until Pin (E) fits tightly behind the back edge of the Door Frame when door is fully closed and lock is in locked position.