

BVV™ FNPT STAINLESS STEEL SIGHT GLASS

Material:	304 Stainless Steel
Maximum Pressure:	125 psi @ 70°F
Temperature Range:	-60° - 180°F
Maximum Vacuum	29 in. of Hg @ 72°F
Country of Origin	China
Use With:	Butane, Propane, DME, Ethanol, Glycol, Air, Hydraulic Fluid, Natural Gas, Phosphoric Acid, and Water
Note:	Chemical compatibility must be determined by the customer based on the conditions in which the product is being used, including the presence of other chemicals, temperature, and consistency.
Manufacturer Certification	ISO 9001:2015
Window Material	Annealed Glass
Seal Material	Buna-N
Pipe Connection Type	Female NPT

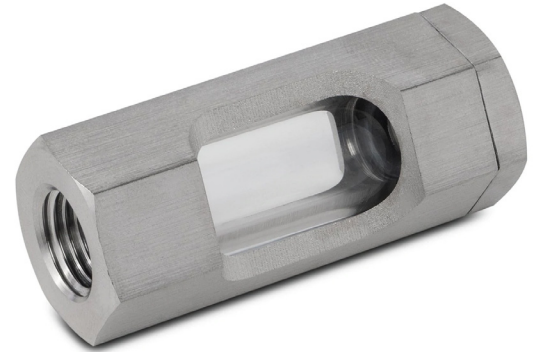

FITTING SPECIFICATIONS

Part No.	Thread Size (in)	Dimensions (in)				
	T1	L1	L	S1	S2	D1
SSSG04	1/4 " X18 NPT	1.000	2.187	0.875	0.100	0.450
SSSG06	3/8 " X18 NPT	1.125	2.250	1.000	0.47	0.51
SSSG08	1/2 " X14 NPT	1.187	2.500	1.250	0.155	0.656
SSSG16	1 " X11.5 NPT	1.250	2.875	2.000	0.200	1.158

BVV™ FNPT STAINLESS STEEL SIGHT GLASS

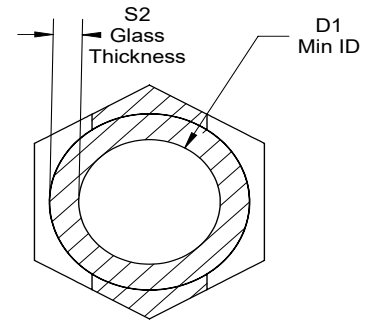
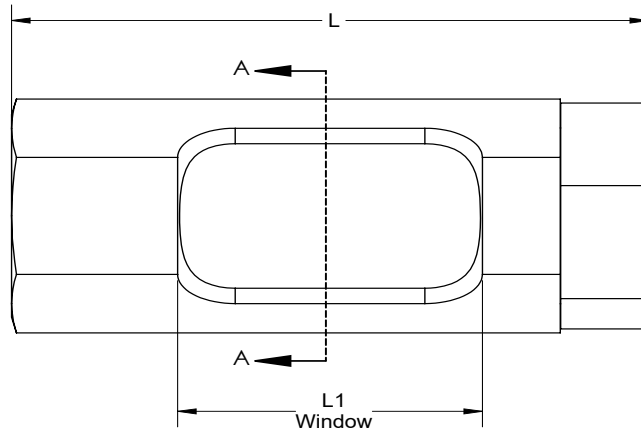
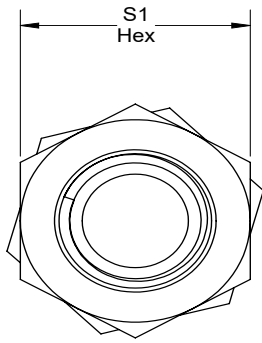
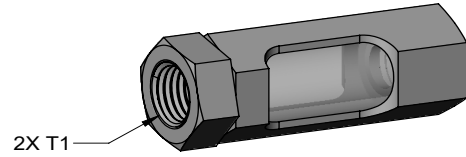

SECTION A-A
SCALE 2 : 1

TITLE: SSSG		MATERIAL: 304 SS		NAME	TOLERANCES UNLESS OTHERWISE SPECIFIED		PROPRIETARY AND CONFIDENTIAL THE INFORMATION CONTAINED IN THIS DRAWING IS THE SOLE PROPERTY OF BEST VALUE VACS. ANY REPRODUCTION IN PART OR AS A WHOLE WITHOUT THE WRITTEN PERMISSION OF BEST VALUE VACS IS PROHIBITED.
DATE: 4/11/2022	REVISION: 00	FINISH: N/A	DRAWN	JB			
SHEET: 1 OF 1	SHEET SIZE: A	UNITS: IN	CHECKED	ENG APPR.	DECIMALS IN MM X +/- .1 +/- .8 XX +/- .01 +/- .25 XXX +/- .005 ANGULAR +/- 1° +/- 1°		