

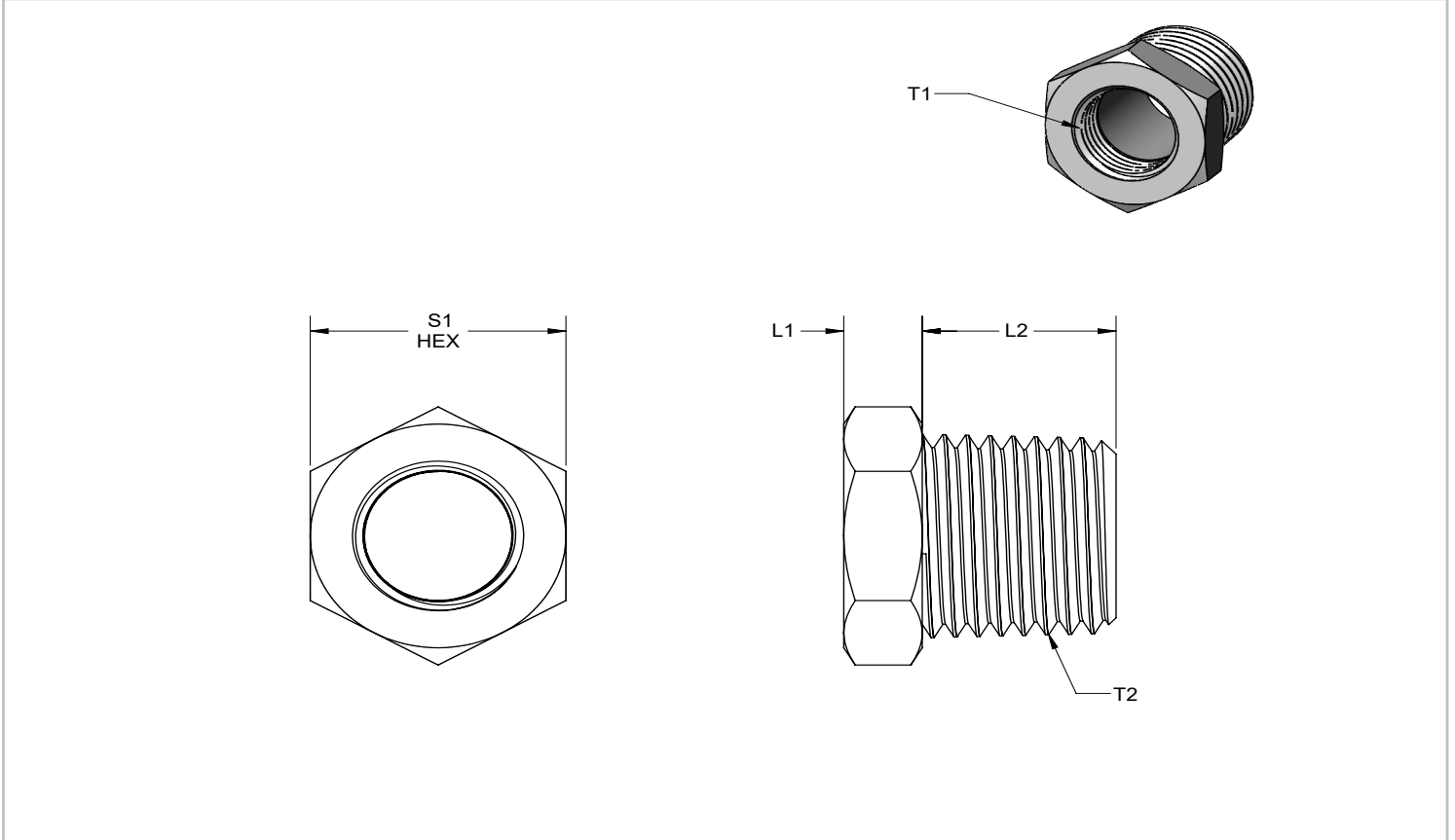

Material:	304 Stainless Steel
Specifications Met:	ASME B1.20.1, ISO 8434, and SAE J514
Maximum Pressure:	2500 psi @ 72°F
Temperature Range:	-320° - 500°F
Maximum Vacuum	29 in. of Hg @ 72°F
Country of Origin	China
Use With:	Butane, Propane, DME, Ethanol, Glycol, Air, Hydraulic Fluid, Natural Gas, Phosphoric Acid, and Water
Note:	Chemical compatibility must be determined by the customer based on the conditions in which the product is being used, including the presence of other chemicals, temperature, and consistency.
Manufacturer Certification	ISO 9001:2015
Pipe Connection Type	NPT
RoHS	RoHS (2015/863/EU) Compliant



FITTING SPECIFICATIONS

Part No.	Thread Size (in)		Dimensions (in)		
	T1	T2	L1	L2	S1
BVV04RB	1/4 " X18 NPT	1/4 " X18 NPT	0.809	0.580	0.668
BVV0406RB	1/4 " X18 NPT	3/8 " X18 NPT	0.290	0.580	0.742
BVV0408RB	1/4 " X18 NPT	1/2 " X14 NPT	0.350	0.760	0.610
BVV0604RB	3/8 " X18 NPT	1/4 " X18 NPT	0.838	0.596	0.861
BVV06RB	3/8 " X18 NPT	3/8 " X18 NPT	0.810	0.620	0.861
BVV0608RB	3/8 " X18 NPT	1/2 " X14 NPT	0.346	0.780	0.861
BVV0804RB	1/2 " X14 NPT	1/4 " X18 NPT	0.965	0.600	1.052
BVV0806RB	1/2 " X14 NPT	3/8 " X18 NPT	1.080	0.676	1.052
BVV08RB	1/2 " X14 NPT	1/2 " X14 NPT	1.141	0.759	1.052
BVV0816RB	1/2 " X14 NPT	1 " X11.5 NPT	0.400	1.000	1.410
BVV12RB	3/4 " X14 NPT	3/4 " X14 NPT	1.166	0.764	1.410
BVV0402RB	1/4 " X18 NPT	1/8 " X27 NPT	0.224	0.536	0.610



TITLE: BVVRB		MATERIAL: 304 SS		NAME	<small>TOLERANCES UNLESS OTHERWISE SPECIFIED</small> <small>DECIMALS IN MM</small> <small>X +/- .1 +/- .8</small> <small>XX +/- .01 +/- .25</small> <small>XXX +/- .00</small> <small>ANGULAR +/- .1° +/- .1°</small>		<small>PROPRIETARY AND CONFIDENTIAL</small> <small>THE INFORMATION CONTAINED IN THIS DRAWING IS THE SOLE PROPERTY OF BEST VALUE VACS. ANY REPRODUCTION IN PART OR AS A WHOLE WITHOUT THE WRITTEN PERMISSION OF BEST VALUE VACS IS PROHIBITED.</small>	
DATE: 3/18/2022		REVISION: 00	UNITS: IN	DRAWN				JB
SHEET: 1 OF 1	SHEET SIZE: A	SCALE: 3:1	CHECKED	ENG APPR.				