

Tri Clamp Flange	OD Flange	OD Tube	ID Tube	T
6"	6.570"	6"	5.782"	0.109"
8"	8.570"	8"	7.782"	0.109"
10"	10.570"	10"	9.732"	0.134"
12"	12.570"	12"	11.732"	0.134"

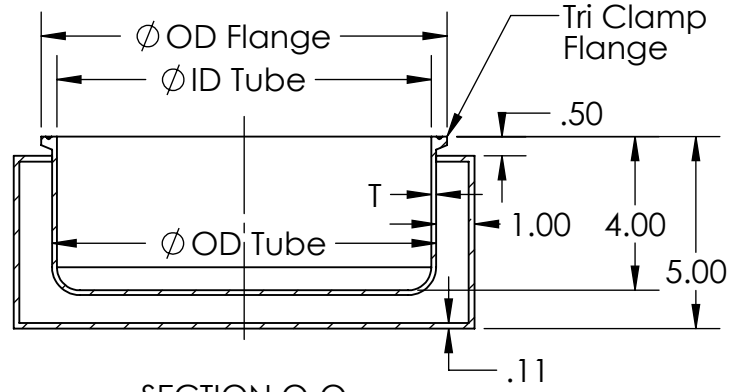

SECTION O-O  
SCALE 1 : 5

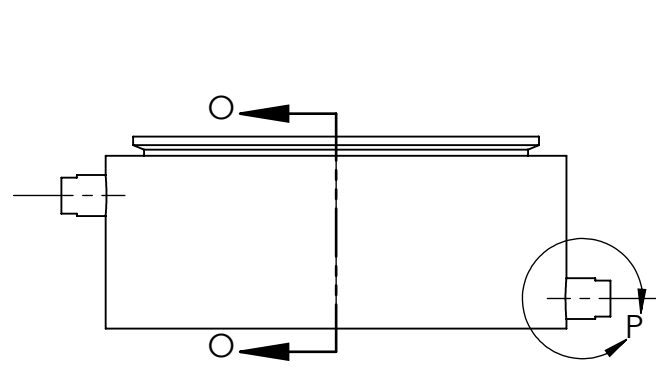
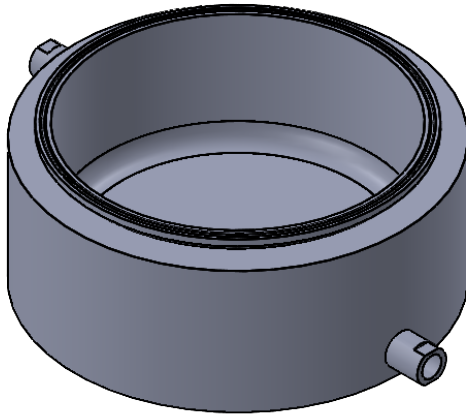
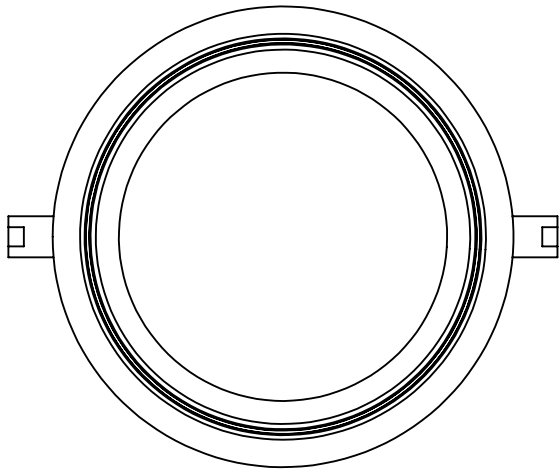
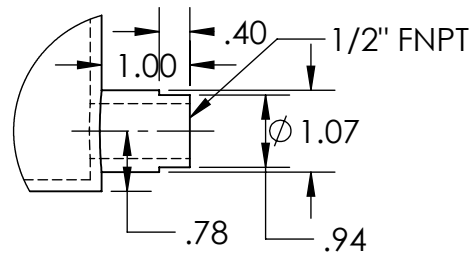

DETAIL P  
SCALE 2 : 5

PROPRIETARY AND CONFIDENTIAL

THE INFORMATION CONTAINED IN THIS DRAWING IS THE SOLE PROPERTY OF BEST VALUE VACS. ANY REPRODUCTION IN PART OR AS A WHOLE WITHOUT THE WRITTEN PERMISSION OF BEST VALUE VACS IS PROHIBITED.

THIRD ANGLE PROJECTION

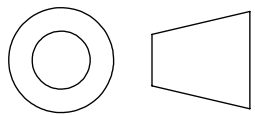

TITLE: JACKETED SPLATTER PLATTERS

DRAWN BY: BVV ENGINEERING

MATERIAL: 304 STAINLESS STEEL

COMMENTS: BUILT TO 3-A CERTIFICATION

BEST VALUE VACS

DATE: 4/12/2022

REVISION: 01

UNITS: INCH

SCALE: 1:3

SHEET SIZE: A

SHEET: 7 OF 12