

Tri Clamp Flange	OD Flange	OD Tube	ID Tube	L	T
1.5"	1.984"	1.5"	1.37"	12", 18", 24", 36"	0.065"
2"	2.516"	2"	1.87"	12", 18", 24"	0.065"
3"	3.579"	3"	2.87"	6", 8", 12", 18", 24", 36"	0.065"
4"	4.682"	4"	3.834"	8", 24", 36"	0.083"
6"	6.570"	6"	5.782"	12", 24", 36", 48"	0.109"
8"	8.570"	8"	7.782"	36", 48"	0.109"

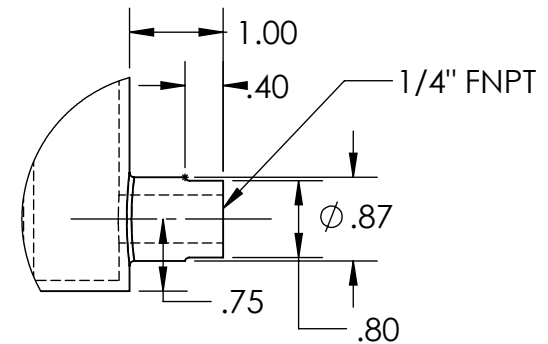
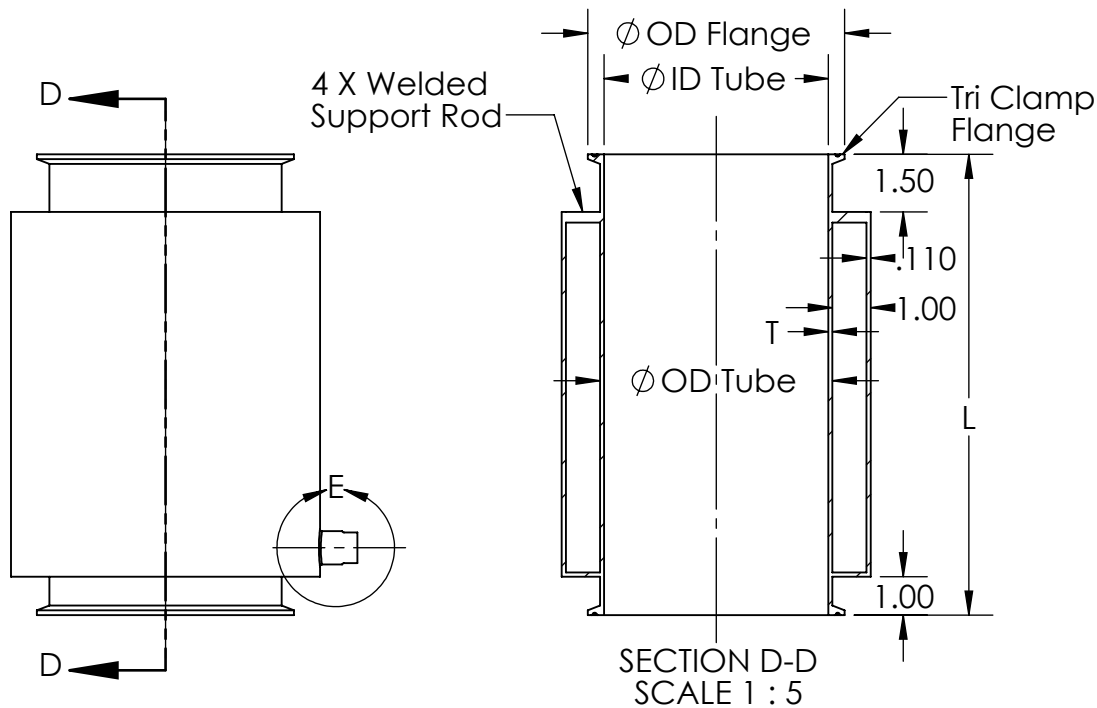

DETAIL E
SCALE 1 : 2

PROPRIETARY AND CONFIDENTIAL

THE INFORMATION CONTAINED IN THIS DRAWING IS THE SOLE PROPERTY OF BEST VALUE VACS. ANY REPRODUCTION IN PART OR AS A WHOLE WITHOUT THE WRITTEN PERMISSION OF BEST VALUE VACS IS PROHIBITED.

THIRD ANGLE PROJECTION

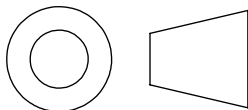

TITLE: DEWAXING COLUMNS

DRAWN BY: BVV ENGINEERING

MATERIAL: 304 STAINLESS STEEL

COMMENTS: BUILT TO 3-A CERTIFICATION

BEST VALUE VACS

DATE: 7/19/2018

REVISION: 01

UNITS: INCH

SCALE: 1:5

SHEET SIZE: A

SHEET: 2 OF 12