

autopilot®

Environmental Controllers

12 OUTLET 240V LIGHT CONTROLLER (FUEL ST12)

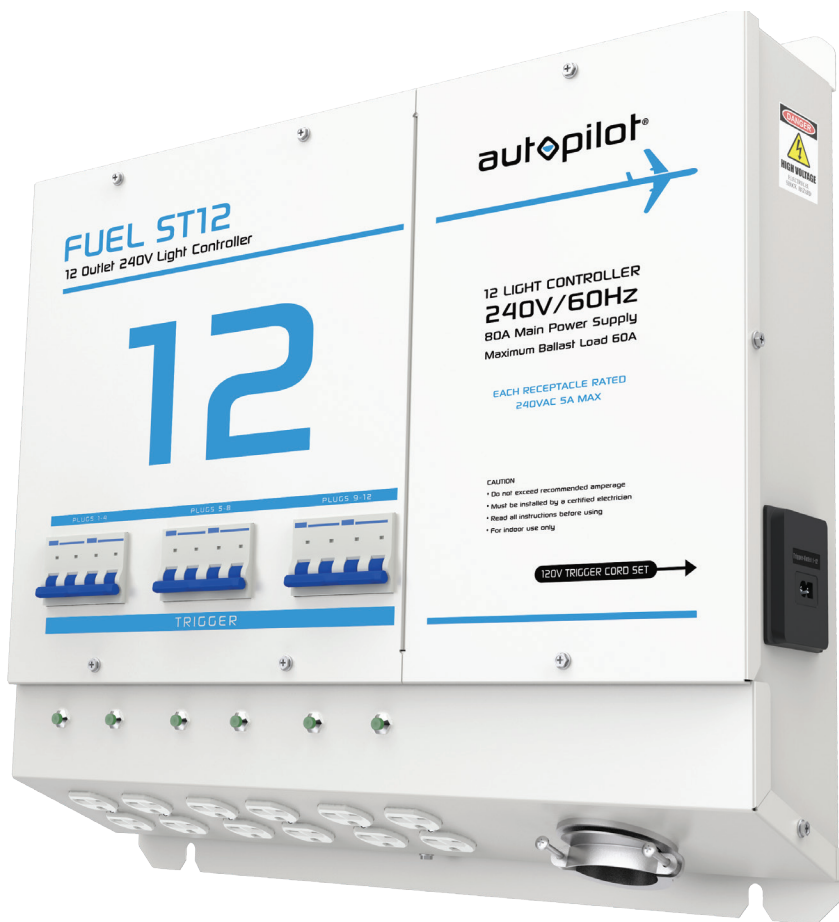

APT0122

OVERVIEW

The **Autopilot FUEL ST12 Twelve Outlet 240V Light Controller** (APT0122) represents the latest in large scale lighting control. It is the best device for operating up to 12 lights from a 24-hour timer or controller. This unit features 240V industrial-grade NEMA 6-15 UL listed power outlets. All outlets are controlled by a single 120V trigger cable. The 12 light controller has 3 banks of 4 lights. Each bank has a 30 second time delay and is protected by an industrial-grade circuit breaker.

The FUEL ST12 requires a 80A main power supply and has a maximum ballast load of 60A. Each power outlet receptacle is rated 240V, 5A maximum. Keep your grow lights in complete control with Autopilot's professional line of FUEL light controllers.

NOTE: This controller should be installed by a certified electrical professional.

For information on additional Autopilot products please visit Hydrofarm.com.

SPECIFICATIONS	
Main Power Voltage	240V
Wire Requirements	Minimum 4 AWG (75°C Cu wire ONLY)
Maximum Wattage	12,000 Watts (1000 Watts per outlet) @240V
Max Input Amperage	80 Amps
Max Output Amperage	60 Amps
Relay Coil Voltage	120 VAC
Hertz	60 Hz
Receptacle Type	Nema 6-15
Operating Temperature Range	40-125° F (4.5-52° C)
Dimensions	21.0"L x 5.20"W x 19.79"H
Weight	27.0 lbs

PARTS LIST - (WHAT'S IN THE BOX)

- A - Controller unit
- B - Wire connectors (x2)
- C - Mounting hardware
- D - 120V trigger cord

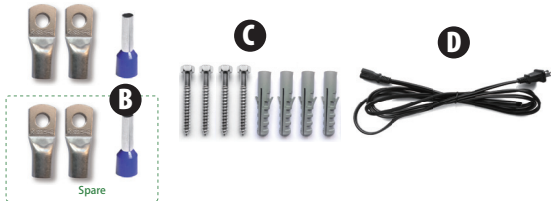
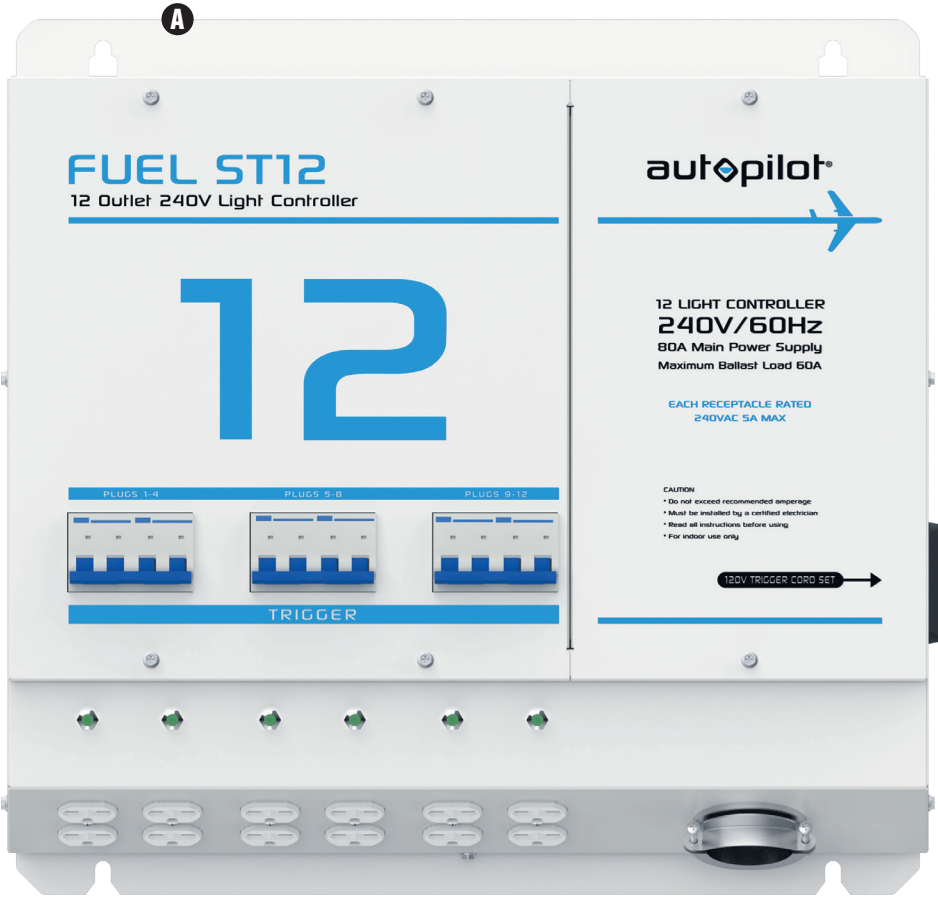

INSTALLATION

WARNINGS

- Must be installed by a qualified electrician.
- All power must be disconnected prior to installing or servicing the equipment.
- A UL-listed minimum 80A circuit breaker must be installed in this application.
- The “Disconnect Service” must be provided by the customer.

CONNECTING THE MAIN POWER

1. Remove the metal cover, once opened you will see the 3 terminals to connect the main power wires.
2. Insert the appropriate sized main power cable into the cable clamp. Connect your incoming 240 Volt power to the 3 connections: **Red/hot leg (L1)**, **Black/hot leg (L2)**, and your **ground wire** (⊕).
3. Remove the insulation from the red and the black main power wires and insert the wire ends into the 2 power connection points marked L1 and L2. During connection of L1, L2 make sure the torque control is set between 6.41–6.74 foot pounds (77–81 inch pounds). **NOTE: Do not exceed 6.74 foot pounds/81 inch pounds, or the wires may be crushed.** Secure the wires tightly to ensure a good connection. Loose connections could cause the connections to overheat, which can cause damage to the unit that is NOT covered by the warranty.
4. Using the volt meter, carefully touch one tester probe to each of the main power connection points. The volt meter should read approximately 240 volts.
5. Once the correct voltage has been verified, carefully reinstall the electrical cover on the unit.

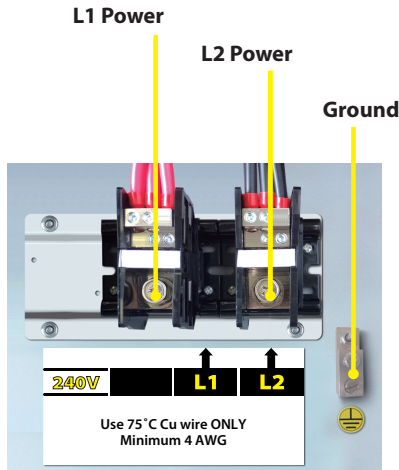
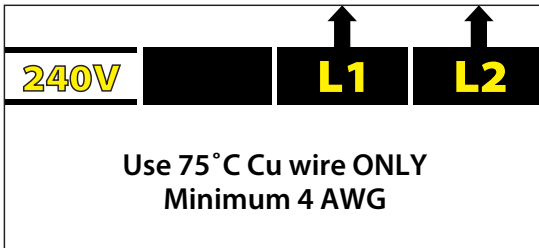

ELECTRICAL DIAGRAM

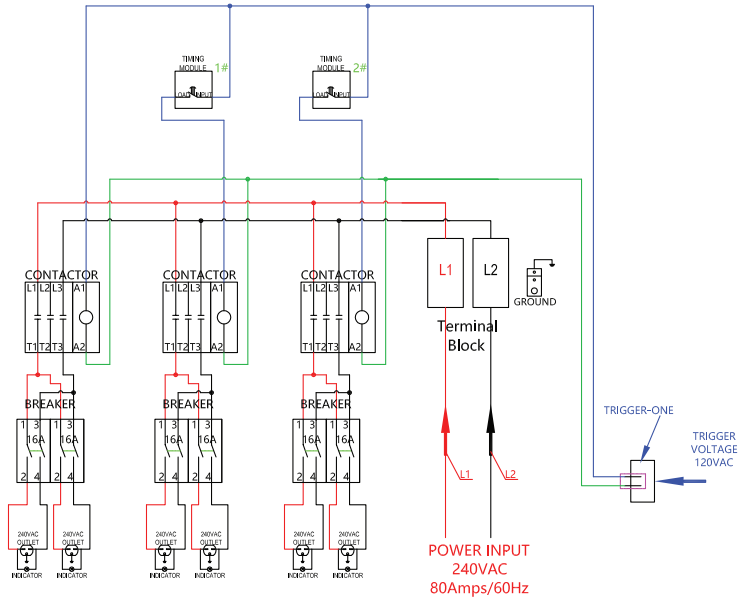

MOUNTING THE CONTROLLER

To be mounted safely, this controller should be secured to solid structural elements, preferably wall joists/studs. In the included mounting hardware you will find four heavy 3" wood bolts intended for mounting into two-by-four joists. If using joists, we recommend the use of a 1/4" drill bit to drill pilot holes for each bolt.

A common mounting method is to bolt the controller to two pieces of 2x4 running horizontally, and then mount by securing those attached 2x4 pieces to the mounting surface. This method is valuable when the spacing of the available joists in the structure does not match up to the spacing of the mounting holes of the controller.

The important thing is to be sure to mount the controller so that its weight is supported securely. We recommend mounting to wall joists or to masonry only.

CONNECT THE TRIGGER CORD SET

Plug the trigger cable into the port on the side of the controller and plug the other end into your timer.



PLUG IN THE BALLASTS

1. Plug your ballasts' power cords into the outlets at the bottom of the controller.
2. You're finished! When your timer turns on for your set lighting schedule, the Fuel ST12 will power the lights according to the timer's on and off settings.

KEY FEATURES

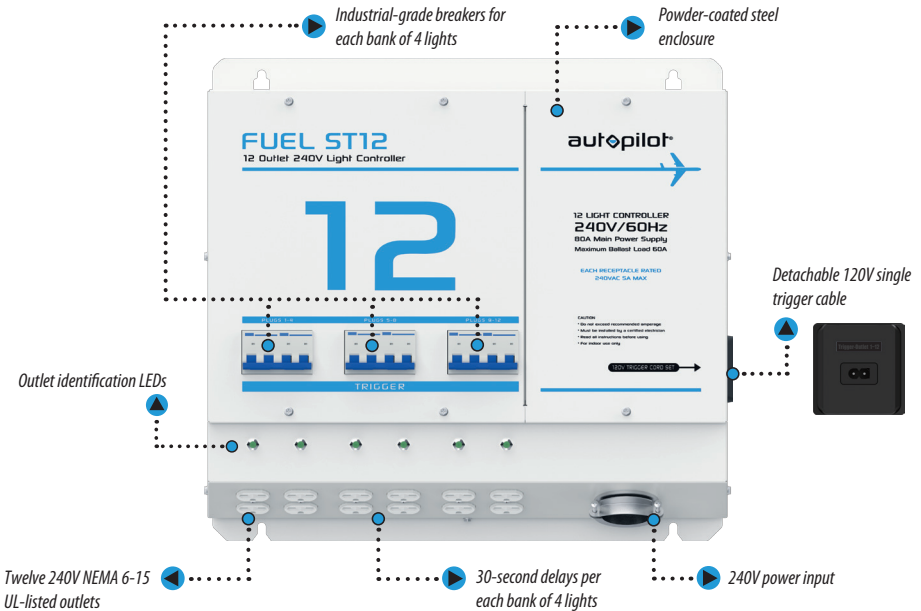

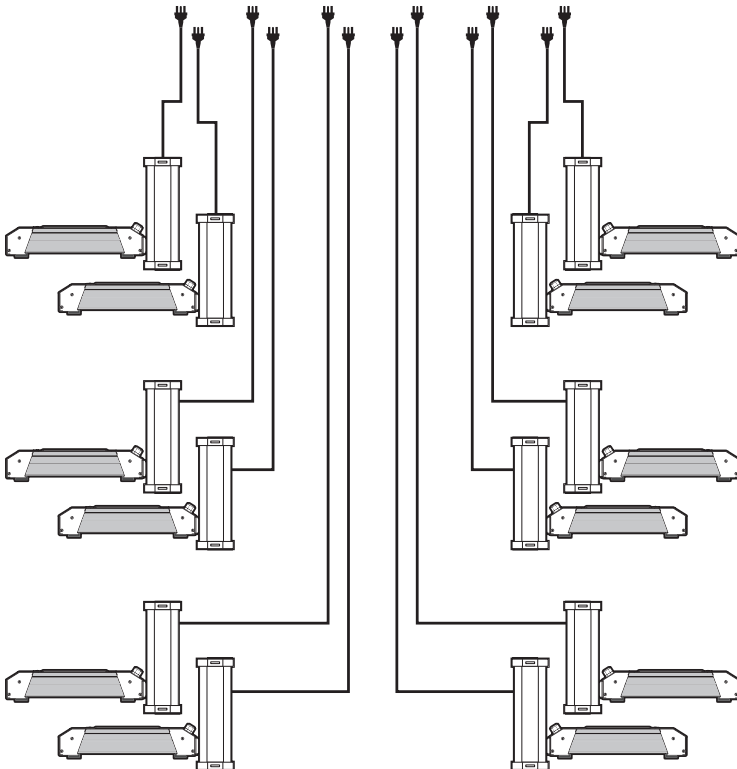
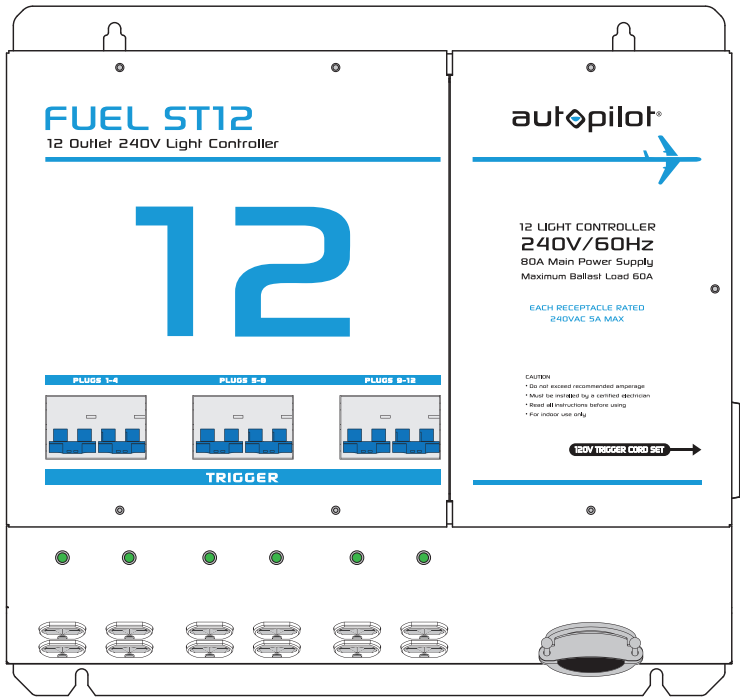

WARRANTY



LIMITED WARRANTY

Hydrofarm warrants the **APT0122** to be free from defects in materials and workmanship. The warranty term is for 2 years beginning on the date of purchase. Misuse, abuse, or failure to follow instructions is not covered under this warranty. Hydrofarm's warranty liability extends only to the replacement cost of the product. Hydrofarm will not be liable for any consequential, indirect, or incidental damages of any kind, including lost revenues, lost profits, or other losses in connection with the product. Some states do not allow limitation on how long an implied warranty lasts or the exclusion of incidental or consequential damages, so the above limitations or exclusions may not apply to you. Hydrofarm will, at our discretion, repair or replace the **APT0122** covered under this warranty if it is returned to the original place of purchase. To request warranty service, please return the **APT0122**, with original sales receipt and original packaging, to your place of purchase. The purchase date is based on your original sales receipt.



Thank you for choosing Autopilot by Hydrofarm. For further information about Autopilot products, videos and technical information, please visit autopilotcontrollers.com

ADDITIONAL LANGUAGES OF THESE INSTRUCTIONS CAN BE FOUND AT Hydrofarm.com



Get Connected with the Hydrofarm Community:



Like us on Facebook, follow us on Twitter, and check out *Hydrofarmtv* on YouTube and Instagram!

APT0122 Instructions revised - January 18, 2018 12:07 PM



Hydrofarm.com