

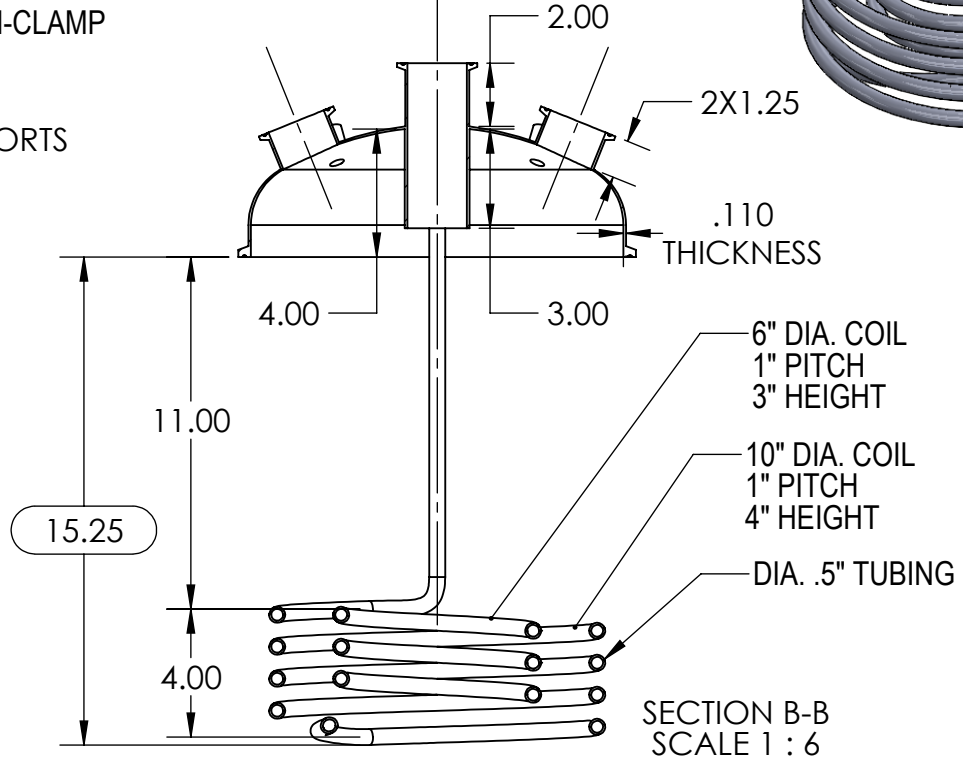

- NOTES:**
- 1) 17MM WRENCH FLATS ON 1/4" FNPT
 - 2) 24MM WRENCH FLATS ON 1/2" FNPT
 - 3) BOTTOM OF COIL APPROX 0.750" FROM BOTTOM OF A 12" SPLATTER (SKU:1200FJS)
 - 4) ALL PORTS EQUIDISTANT AT 45°
 - 5) APPROX. 223.4" OR 18.62' TOTAL COIL LENGTH

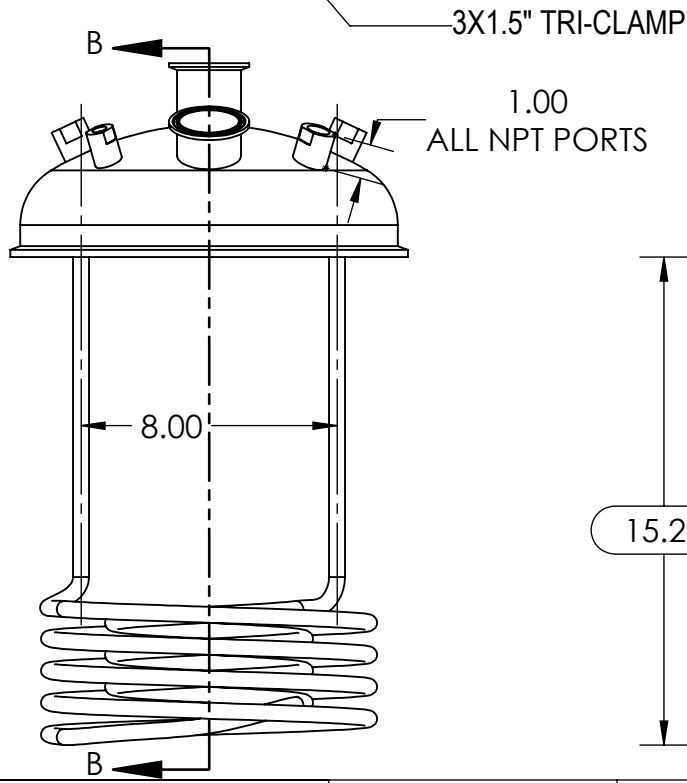
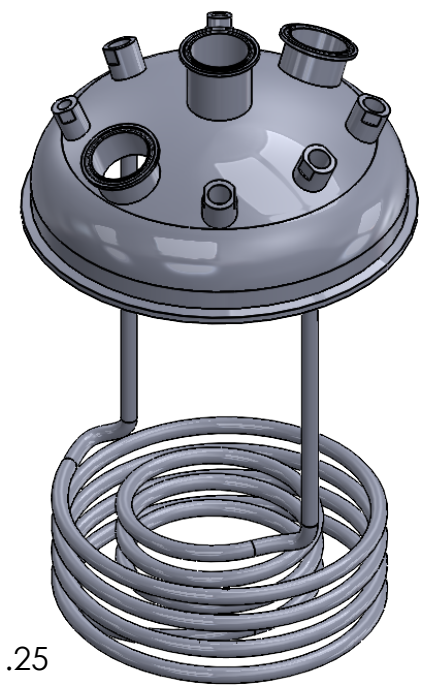

SECTION B-B
SCALE 1 : 6

TITLE: 1200X12-HEL-COIL-V2		MATERIAL: 304SS	NAME	TOLERANCES UNLESS OTHERWISE SPECIFIED		PROPRIETARY AND CONFIDENTIAL THE INFORMATION CONTAINED IN THIS DRAWING IS THE SOLE PROPERTY OF BEST VALUE VACS. ANY REPRODUCTION IN PART OR AS A WHOLE WITHOUT THE WRITTEN PERMISSION OF BEST VALUE VACS IS PROHIBITED.
DATE: 6/9/2021	REVISION: 01	FINISH: N/A	DRAWN JC			
SHEET: 1 OF 2	SHEET SIZE: A	UNITS: INCH	CHECKED JM			
		SCALE: 1:6	ENG APPR. JC			

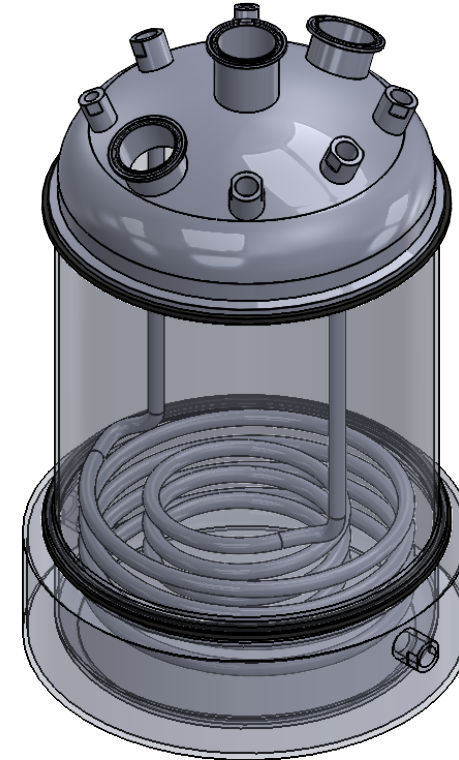
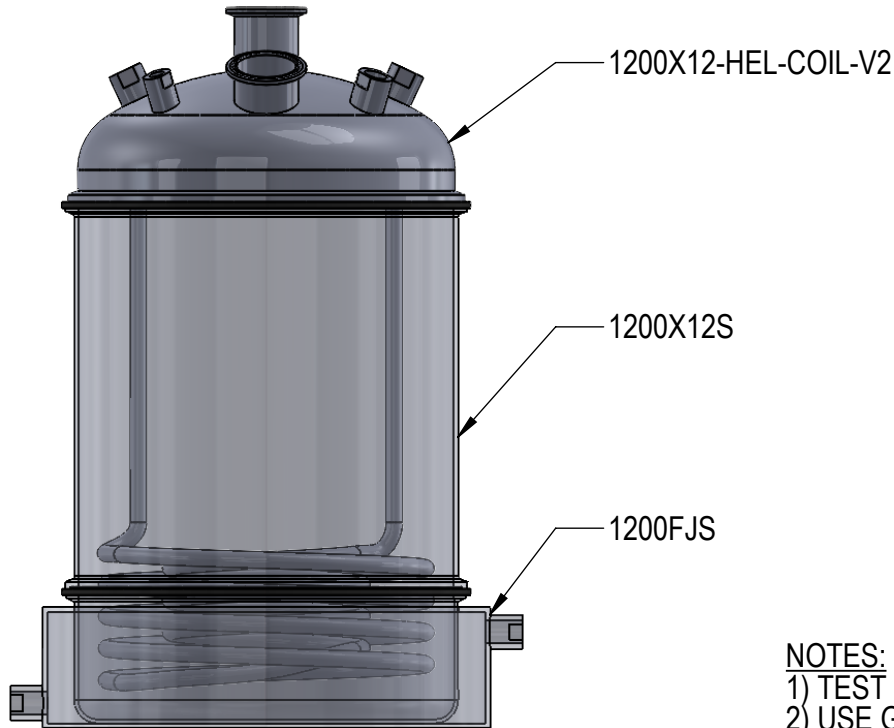
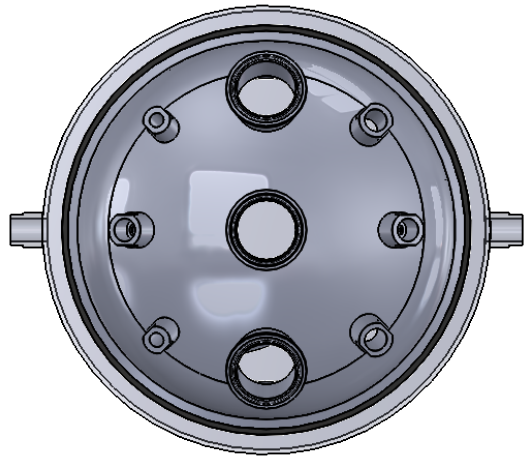

NOTES:
 1) TEST FITMENT ON 1200X12S AND 1200FJS (APPROX. 0.750" FROM BOTTOM)
 2) USE GASKET BETWEEN CONNECTIONS FOR BEST FITMENT TEST

TITLE: 1200X12-HEL-COIL-V2 ASSEMBLY		MATERIAL: 304SS		NAME	TOLERANCES UNLESS OTHERWISE SPECIFIED	 <small>BUILDING VISION AND VARIETY</small>	PROPRIETARY AND CONFIDENTIAL THE INFORMATION CONTAINED IN THIS DRAWING IS THE SOLE PROPERTY OF BEST VALUE VACS. ANY REPRODUCTION IN PART OR AS A WHOLE WITHOUT THE WRITTEN PERMISSION OF BEST VALUE VACS IS PROHIBITED.
DATE: 6/9/2021	REVISION: 01	FINISH: N/A	DRAWN	JC			
SHEET: 2 OF 2	SHEET SIZE: A	UNITS: INCH	CHECKED	JM	DECIMALS IN X +/- .1 XX +/- .01 XXX +/- .005 ANGULAR +/- 1°		
		SCALE: 1:6	ENG APPR.	JC			