

EFFYDESK

Instruction Manual

Technical Data

Segment Column	2	Input Voltage	110-240V
Maximum Load	240 lbs	Speed	30mm/s
Recommend Load	< 220 lbs	Certification	UL
Height Range	710-1160mm		

Accessory List

Ax8 M6X12	Bx4 M6X8	Cx12 M5X18 or M6X16
Dx5 Zip Tie	Ex12 Rubber Pad	Fx2 M4X12
		Gx8 M6X16
Hx8 M8X10		

Tool Required

4mm Allen Key (included)	Tape Measure
Screwdriver	

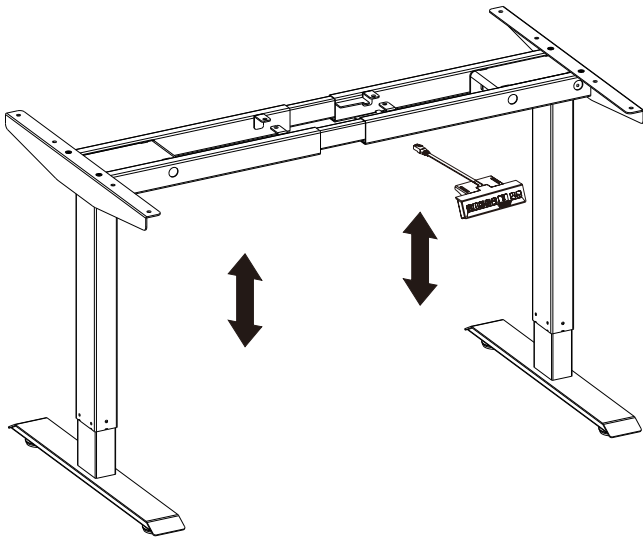

Parts List

No.	Control Box	Qty
①		1

No.	Power Cable	Qty
②		1

No.	Lifting Column	Qty
③		2

No.	Foot	Qty
④		2

No.	Extension Cord	Qty
⑤		1

No.	Side Bracket	Qty
⑥		2

No.	Keypad	Qty
⑦		1

No.	Crossbar	Qty
⑧		1

Thank you for your order!

If you have any issues with your product, please feel free to contact us via team@effydesk.ca or info@effydesk.ca We will help you resolve the issue as soon as possible.

For more information, please visit

<https://effydesk.ca/pages/how-to-assemble-your-height-adjustable-standing-desk>

STEP 1

Separate the Crossbar ⑧ and you will find the Crossbar Rail inside.

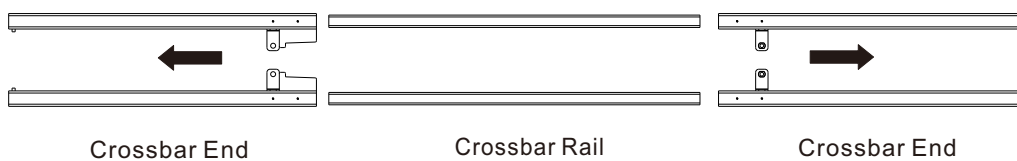

STEP 2

Insert one of the Crossbar Ends into the one of the Lifting Columns ③ and secure with screws. Repeat the same step for the other Lifting Column.

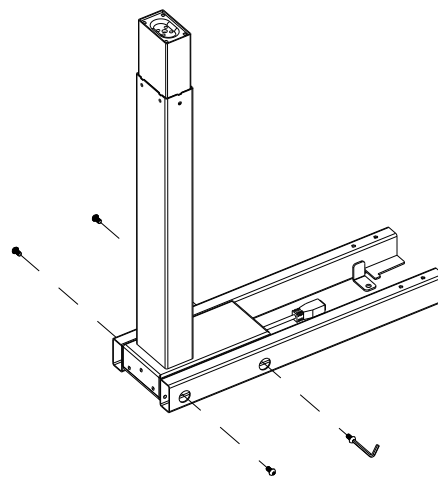
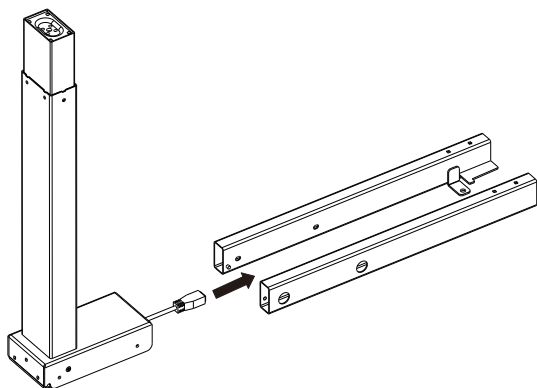

STEP 3

Attach the Side Bracket ⑥ to one of the Lifting Columns. Repeat the same step for the other Lifting Column.

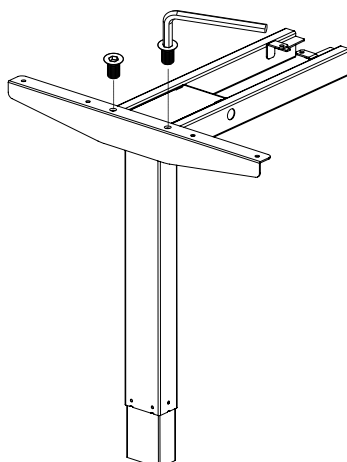
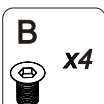

STEP 4

Slide the two Crossbar Ends back into the Crossbar Rail.
Please make sure to fit the slots as shown below.

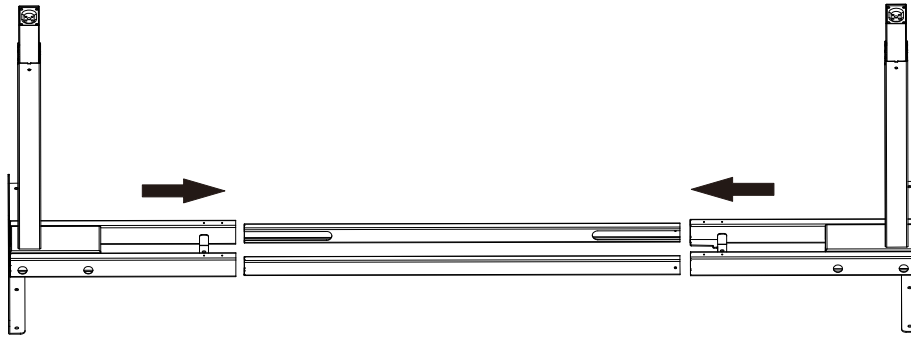

Note: Please make sure the circular holes are facing inwards as shown below.



Slider for Control box

STEP 5

Attach both Feet ④ to the bottom of the Lifting Columns.

G

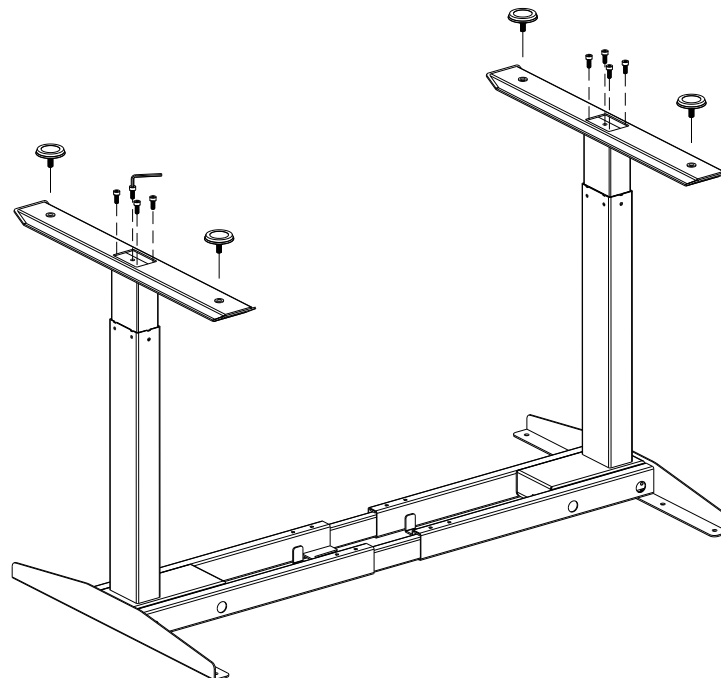

STEP 6

Install the tabletop (Predrilled / Non-predrilled).

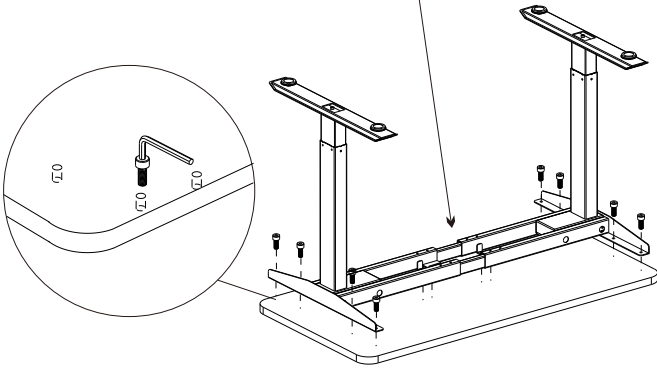
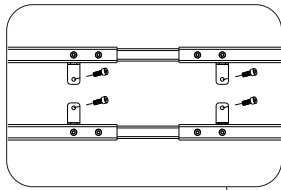

Predrilled

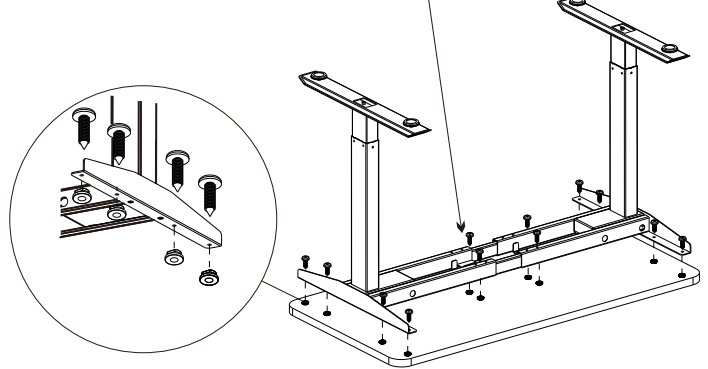
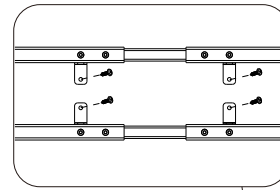
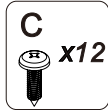

Non-predrilled

Note: Please do not over-tighten the screws.

STEP 7

Connect all the cables to the Control Box ①.

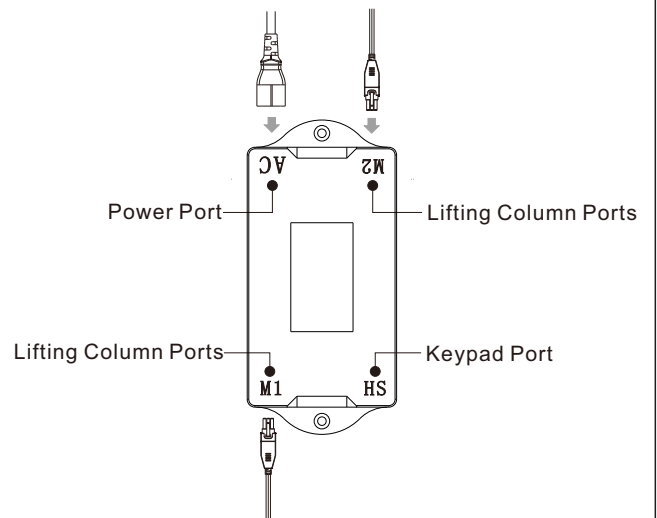
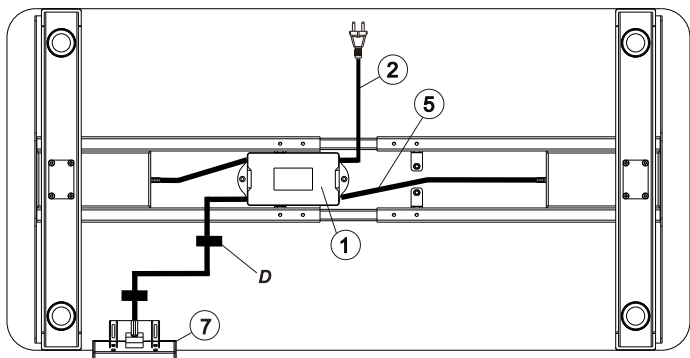

Note : Use Zip Ties (D) to secure cables under the table.

STEP 8

Firmly secure the Crossbar with Screws (A) and attach the Keypad ⑦ with Screws (F) to the tabletop.

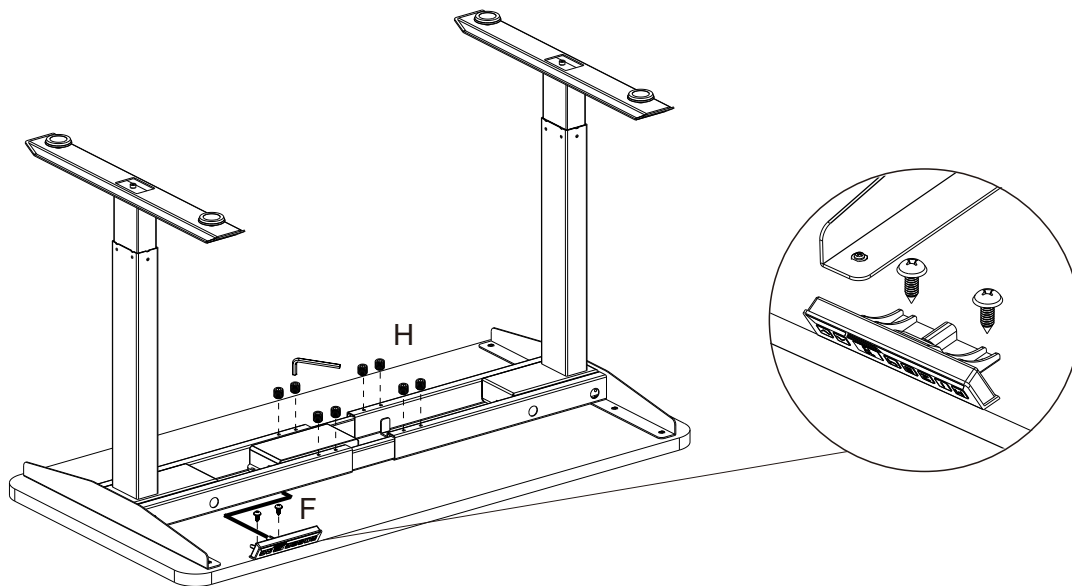
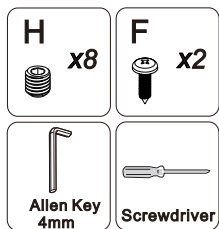

STEP 9

Plug the cable from the Keypad into the Control Box and flip the table onto its feet.

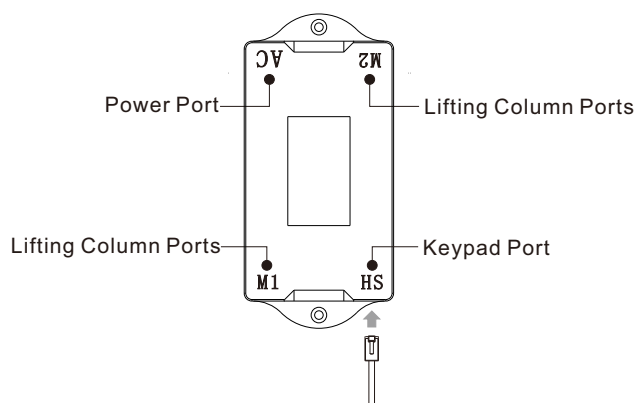
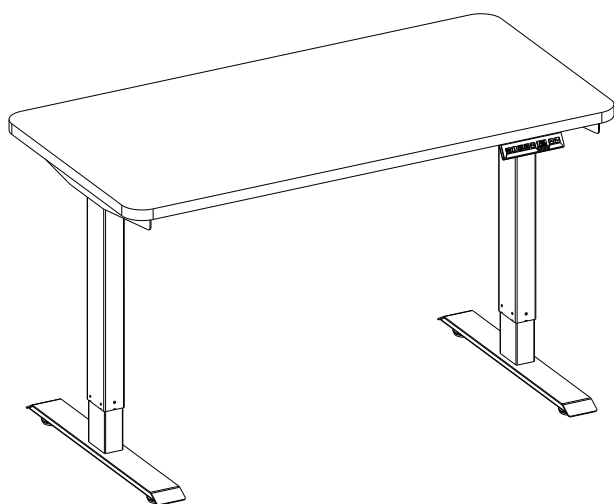

Note: The Control Box is equipped with a gyro sensor so the table and the Control Box must be level in order to work properly or else it will not move up and down.

Prepare for First-time Use

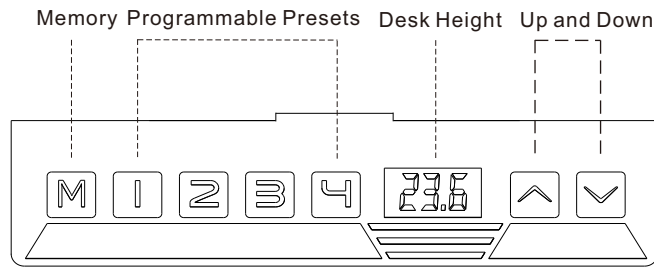

Before plugging in the table, make sure that:

- The Lifting Columns are level and set at their lowest position.
- All the screws are tightened to avoid the desk from becoming wobbly.
- There is no object above or beneath the desk within its range of movement as it may result in physical damage.

Calibrate the desk by following the steps below:

- Please press the Down button and hold for 10-15 seconds until the table stutters and beeps.
- Release the button. Your desk is ready to use!

Operation Guide

Program Presets

- Adjust the table to the desired height, then press M.
- "S-" will flash on the display.
- Press a number to set the desired height as a preset.

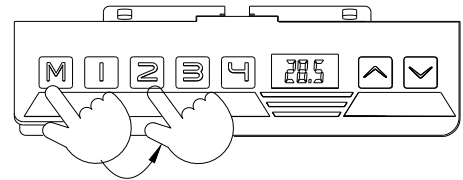

Set Stand Up Reminder

- Press and hold the number 1 and 3 buttons at the same time.
- When display shows "0.0h", press the Up or Down arrows to adjust the reminder time by 30 minute (0.5 hr) increments.
- Once the display stops flashing, your reminder has been set.
- Repeat above steps to set another reminder for next time.

Advanced Safety Feature: Lock and unlock the table

- Press the Up and Down buttons at the same time for 5 seconds, until "LOC" appears on the display.
- All buttons will be deactivated and no changes can be made.
- Press the Up and Down buttons together again to unlock the Keypad and all of the table's features.

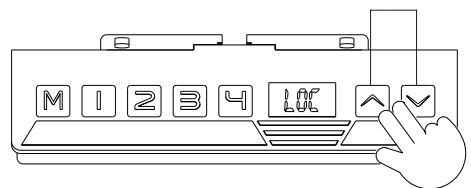

Set Maximum Height Limit

- Raise the desk to the desired maximum height.
- Press M and the Up button together for 5 seconds until you hear a beep. This sets the maximum height limit.

Set Minimum Height Limit

- Lower the desk to the desired minimum height.
- Press M and the Down button together for 5 seconds until you hear a beep. This sets the minimum height limit.

Changing from Centimetres to Inches

- Press M for 10 seconds, the Keypad will display "1-1".
- Press the Down button and it will change to "1-0".
- Press M for 10 seconds to lock the setting.

Reset the table

When an error code or “RST” appears on the display, please reset the table.

- Unplug the power cord from the Control Box.
- Unplug the cable that connects the Keypad to the Control Box.
- Wait 30 minutes and plug all the cables back in again.
- Press the Down button and hold for 10-15 seconds until the table stutters and beeps.

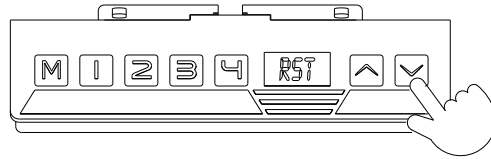

Press by holding
10-15 seconds

If “HOT” appears on the display

- Please unplug and replug and let it cool off for a couple of minutes before proceeding.

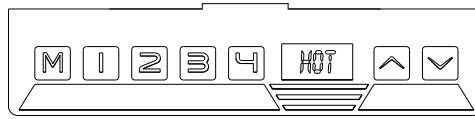

EFFYDESK

If you have any questions, please contact us at

team@effydesk.ca or info@effydesk.ca

www.effydesk.ca